

Duct Heaters Installation Manual

The information and instructions in this sheet apply to Duct Heater models for zero clearance installation in ducts.

The Duct Heaters are approved for use with heat pumps, air conditioners, or other forced air systems. They may be controlled by contactors, relays, sequencers or solid state devices.

The Duct Heaters are prewired, have voltage ratings to 600 volts, both single phase and three phase.

The Duct Heaters are furnished with integral controls, except for the DD & DHD series, which are furnished with a separate control panel for remote mounting.

GENERAL:

Inspect heater for any possible shipping damage. Check all insulators for breakage and inspect heater element wire for any deformation that could cause a short circuit or ground. Make sure all fasteners are tight. Electrical connections such as pressure terminals should be checked for tightness.

INSTALLATION:

For safe operation and best performance, the following installation procedures must be adhered to.

Heaters may be installed in the sides of either horizontal or vertical ducts but never in the top or bottom of a horizontal duct. Heaters installed in vertical ducts are tested and approved for up airflow only!

1. Install a heater a minimum of (4) feet from heat pumps or central air conditioners.
2. At least 4 feet downstream from an air handler.
3. At least 2 feet either side of an elbow or turn.
4. At least 4 feet from any canvas duct connector or transition section for change in duct size.
5. At least 4 feet downstream from an air filter.
6. At least 4 feet upstream from a humidifier.

Refer to the back of this sheet for: duct, electrical and air velocity requirements.

To install a slip-in heater FIG.1, cut an opening, as required in the side of the duct. Slide heater in the duct using control box as template to mark the mounting screw holes. Remove unit and drill mounting holes. Mount unit to duct with sheet metal screws. Connect high and low voltage supplies along with fan interlock circuit (if no airflow switch is furnished). Larger heaters may require hangers.

To install a flange type heater FIG.2, Insert heater between two sections of flanged duct and bolt in place. For additional strength, the duct flange should be doubled as shown in the figure. Large heaters may require hanger straps. Connect high and low voltage supplies along with fan interlock circuit (if no airflow switch is furnished).

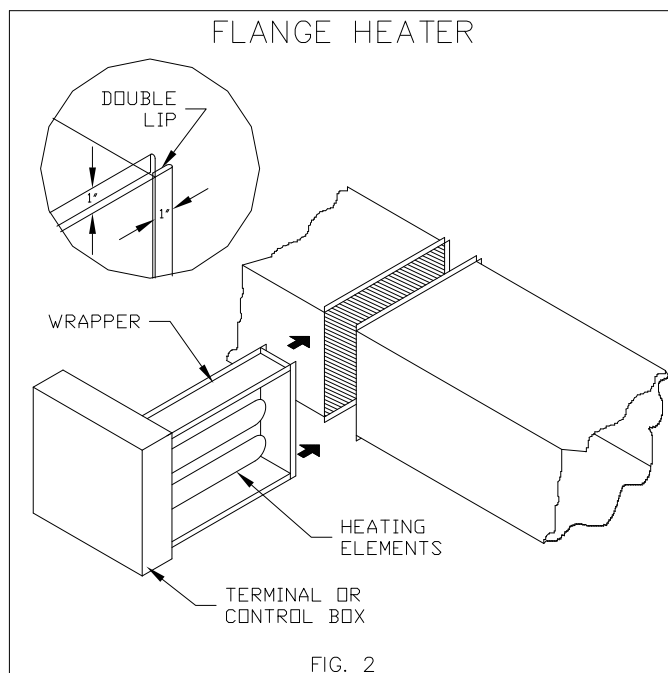
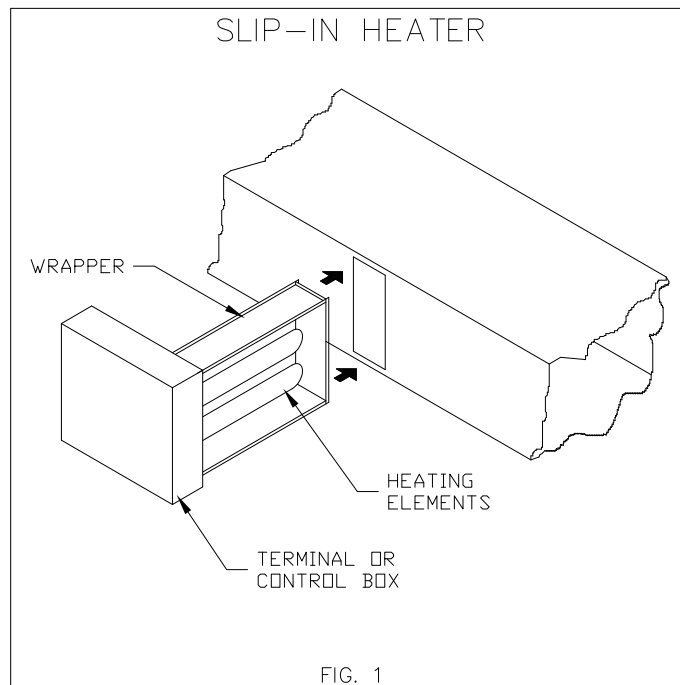

The air duct should be installed in accordance with the Standards of the National fire Protection Agency for the Installation of Air-Conditioning and Ventilating Systems (Pamphlet No. 90A) and Warm-Air Heating and Air-Conditioning Systems (Pamphlet No. 90B).

Do not "Bank" heaters (side by side). If greater capacity is required, proportion smaller heaters in separate runouts. Heater control boxes must be completely accessible and located to provide ventilation at all times.

ELECTRICAL REQUIREMENTS

Refer to attached wiring diagram and wiring diagram on inside of cover. Make sure line and control voltage of system matches that noted on wiring diagram.
 Wire in accordance with N.E.C. and any existing local codes.
 Check tightness of all factory and field electrical connections.
 Make sure fan interlock is wired in if the Duct Heater does not have an air flow switch.
 Use 90 C (194 F) copper wire.
 Control must be wired for N.E.C. Class 1 unless otherwise specified.

When heater has integral transformer for control voltage to thermostat, use thermostat with isolating contacts to prevent interconnection of Class 2 outputs.

Disconnect all electrical power before servicing. When servicing heater, make sure all components are repositioned in the proper location and reconnected per the wiring diagram.
 Replacement parts must be identical to the original components.
 Contact factory for replacement parts.

MINIMUM AIR VELOCITIES

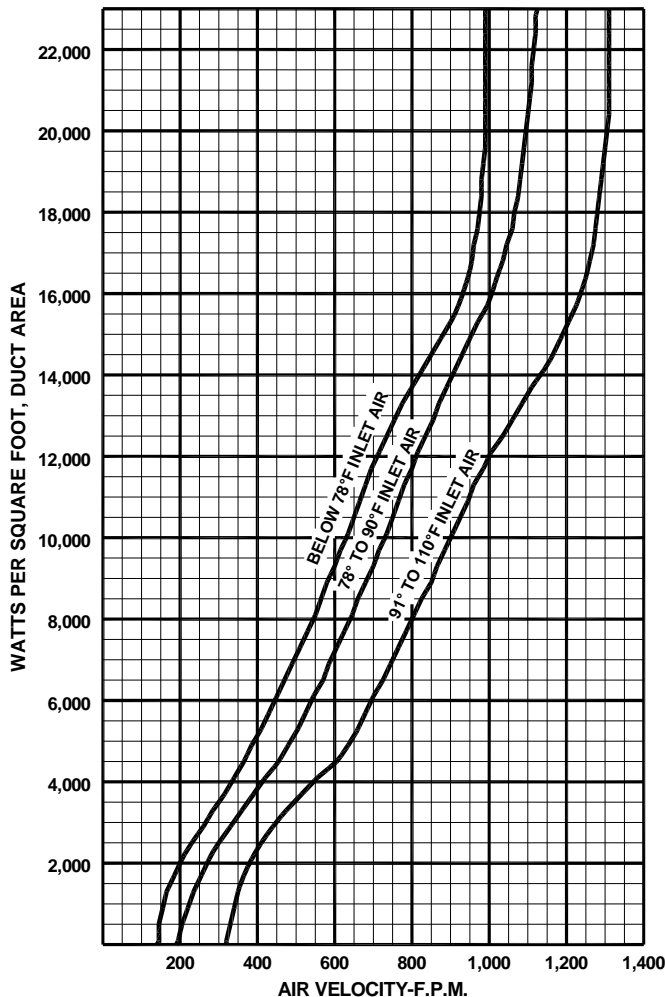

The minimum uniform airflow in a duct heater is directly related to the inlet air temperature. Consideration must be given to both airflow across the heater and inlet air temperature, (shown at left).

- To calculate the watts per sq. ft. of duct area, divide the total watts required by the duct area.

EXAMPLE: Duct Size = 2ft. x 3ft.
 Total watts = 20,000
 W/Sq. Ft. = $\frac{20,000}{6} = 3333$

- If the air handler equipment is expressed in F.P.M. then a direct cross reference can be made by comparing the temperature of the air (as it enters the Duct Heater) to the KW rating on the chart of rated velocity.
 - Draw a line horizontally from the Watts/Sq. Ft. required to the inlet air temperature being used.
 - From this point of intersection on the Inlet Air Curve, draw a line down vertically to establish the air velocity.
 - The velocity should never be lower than the velocity as determined from the chart. In cases where this is not true, the velocity must be increased or the KW required must be reduced.
- In cases where the air handling equipment is expressed in C.F.M. then convert to F.P.M. by dividing the C.F.M. by the duct area.

EXAMPLE: F.P.M. = $\frac{C.F.M.}{\text{Duct Area}}$

NOTE: MINIMUM AIRFLOW MUST BE MAINTAINED AT ANY POINT OVER THE FACE OF THE HEATER

NOTE: OBSERVE AT LEAST ONE COMPLETE HEATING CYCLE TO INSURE THAT CYCLING OF THE SAFETY LIMIT CONTROLS DOES NOT OCCUR BEFORE LEAVING THE INSTALLATION.