

KFUH Electric Unit Heater

Installation Instructions



DANGER
SHOCK HAZARD: Shut off circuit breaker now

“WARNING: RISK OF ELECTRIC SHOCK. CAN CAUSE INJURY OR DEATH. DISCONNECT ALL REMOTE ELECTRIC POWER SUPPLIES BEFORE SERVICING.”

CAUTION: Turn off power source supplying the heater before attempting installation, maintenance or repairs. Lock or tag circuit breaker or fuse panel door. Failure to do so could result in serious electrical shock, burns, or possible death.

It is **extremely important** you verify the electrical power supply is the same voltage as the heater being installed. 240 and 480 Volt heaters are **not** interchangeable. Powering a 480 Volt unit with 240 Volt supply wires will reduce the heater output by approximately 75% and is never recommended. Powering a 240 Volt unit with 480 Volt supply wires will destroy the heater and voids all warranties.

CHECK: Ensure blower wheel is free-turning and that element assemblies are in place. Be sure filter is in proper position and not torn or damaged. Check that blower housing and motor have not separated from element compartment during shipment.

FIELD WIRING

208 and 240 Volt heaters are equipped with circuit breakers over 48 Amps to provide internal circuit protection and a field disconnect on the unit. A terminal block provides a single strike for field wiring. 480 Volt units do not have circuit breakers but are fused when internal protection is required and are also supplied with terminal blocks for field wiring. Consult the National Electric Code for proper wire size and service circuit breaker protection.

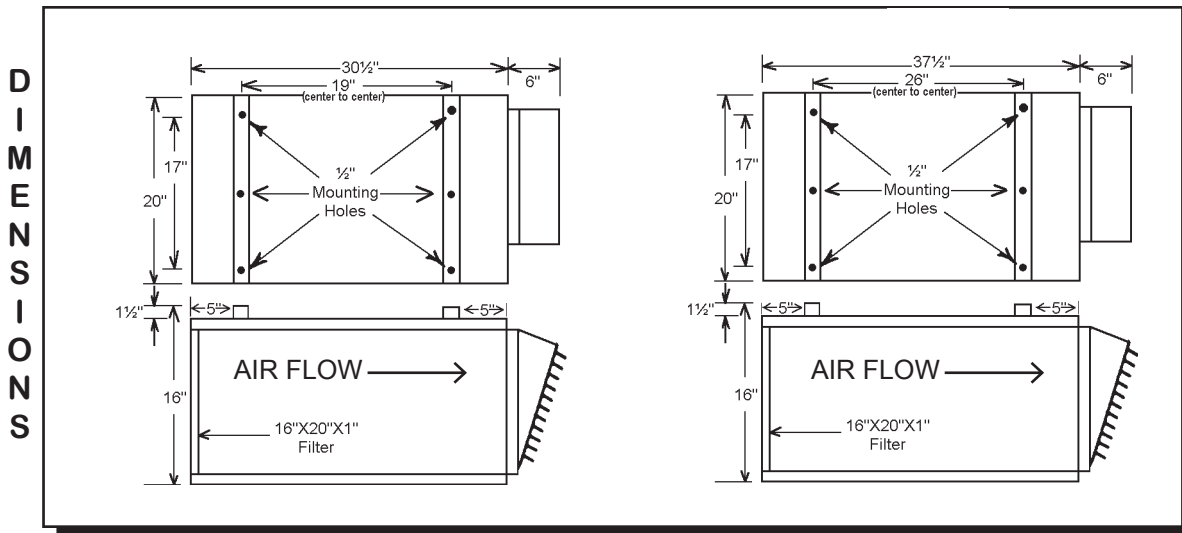
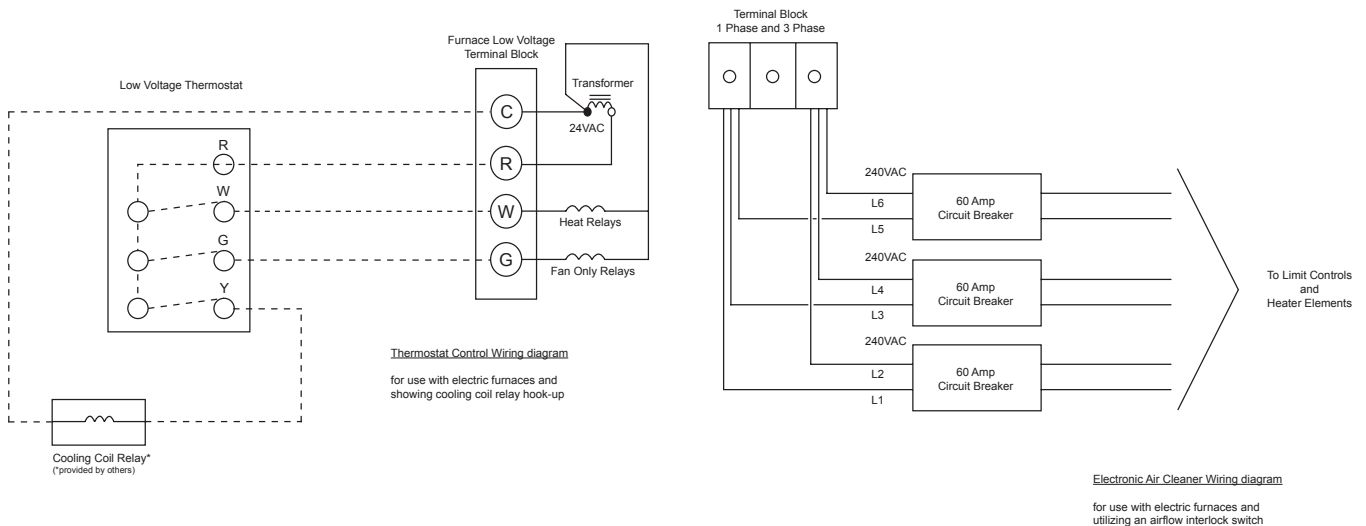

Mounting

KFUH heaters can be mounted vertically or horizontally as shown. 3/8" weldnuts are welded into brackets and will accept 3/8 threaded rod. A minimum of 6 inches clearance to vertical and horizontal surfaces and 6 feet minimum above floor are required. Louvers can be adjusted for desired airflow.

Application Tips

First, calculate the heating loads in the conventional way using the N.E.M.A. handbook or ASHRAE guide. Next, determine quantity and size of heaters to be used. In instances where large groups of people are normally settled in the same location, use a large number of smaller kW unit heaters. (Example: people on a production line or skilled machine operations.) By utilizing heaters in this manner one can best distribute uniform heat, prevent hot drafts, reduce potential noise levels and balance the electrical operating demand.

When considering warehouse areas or storage rooms (where heat distribution and constant temperatures are less important) use fewer heaters of higher capacity.

To maintain uniform heat and reduce stratified air it is recommended that the total CFM of the units turn the air over approximately 3 times per hour.

Horizontal Mount

Smaller rooms can be heated by one unit heater. Where two walls are exposed heaters should be mounted as shown.

In larger rooms, units should be located so their air streams wipe exposed walls without

blowing at them. Units should be located so that the air stream of one supports that of another thus setting up a circulatory air movement. (Distance between units to be approximately 1½ times published air throw).

Units should not be mounted horizontally in areas having ceiling heights in excess of 10 to 12 feet.

Vertical Mount

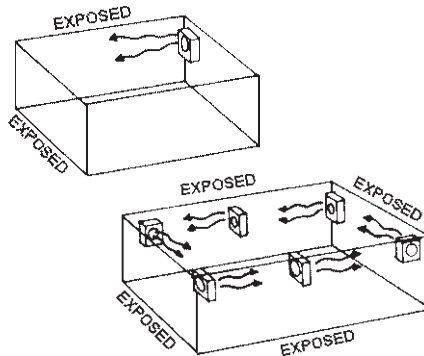

Units should be mounted vertically where they may otherwise interfere with assorted material, handling equipment and in high bay areas. Heaters should be situated to provide free air circulation. Size and selection of units should be based on recommended mounting height.

Unit heaters are frequently used to combat cold air inrush when loading dock doors are opened. For such applications, one or more units should be arranged to blow warm air vertically in front of opening.

Dual Mounting

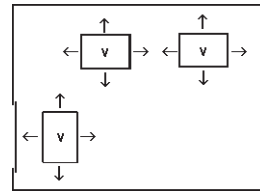

Where square footage is large and comfort essential, both horizontal and vertical installations may best serve your requirements.

Mounting Limitations

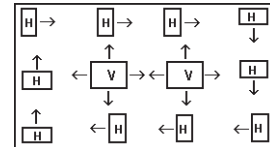

KFUH unit heaters should not be used in potentially explosive atmospheres. The finish is not intended for direct salt spray exposure in marine applications or the highly corrosive atmospheres of swimming pools, chemical storage bins, etc. Please refer to the factory for explosion proof or marine application heater information.

Do not install unit heaters above recommended maximum mounting height. Obstructions must not block unit heater air inlet or discharge. To prevent possible injury heaters must be mounted at least 6 feet above the floor to prevent accidental contact with the heating element or fan blade.

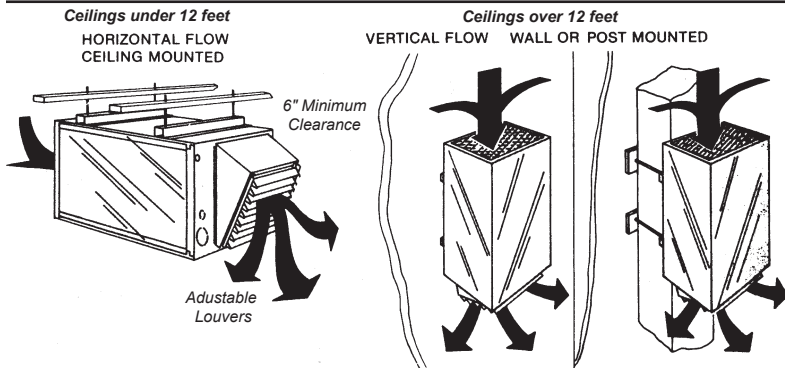

AIR DELIVERY CHART @ .2 static								
MOTOR SPEED								
Motor HP	Motor Load		Low		Med		High	
	Voltage	Amps	CFM	FPM	CFM	FPM	CFM	FPM
1/5	230	3.4	775	570	860	630	1000	735
	380/460	1.7					1000	735
1/3	230	3.2	1100	810	1250	920	1540	1130
	380/460	1.7	1100	810			1540	1130
1/2	230	3.8	1250	920	1540	1130	1750	1285
	380/460	1.9					1750	1285
Wire Color			Red		Blue		Black	
Air Volume = Cubic Feet per Minute (CFM)								
Air Velocity = Feet per Minute (FPM)								

The following accessories and/or options may have been ordered with your unit.

Model	Description
1E30-910	24V Wall Thermostat, range 50° - 90°
KFUH-90D	90 Degree Elbow w/ adjustable louver diffuser
KFUH-RD	Radial Diffuser
KFUH-90RD	90 Degree Elbow w/ radial diffuser
KFUH-PTBL	Kit includes casters and mounting bracket to create a Portable KFUH (no power cord)

Add Suffix	Description
-T	1-Pole thermostat - factory installed
-2TS	2-Stage thermostat - factory installed
-SF	Summer fan switch - factory installed
-BR	Blower relay for remote fan only operation
-2S1	2-Stage control, 1-Phase models
-2S3	2-Stage control, 3-Phase models
-DS40	40 Amp 3-Pole non-fused disconnect switch
-DS60	60 Amp 3-Pole non-fused disconnect switch
-DS80	80 Amp 3-Pole non-fused disconnect switch
-DS100	100 Amp 3-Pole non-fused disconnect switch
-ND	No diffuser - 1" duct collar provided on discharge side for connection to 14" x 14" duct

CONTROL WIRING

Connect thermostat to terminals R and W for heating, R and G for air only. This can be done with a single stage heat-cool thermostat or a single stage heat-only thermostat and a separate fan-only switch to control the fan-relay (optional) installed on furnaces. Some models of furnace have two stage operation (optional) and are provided with terminals W1 and W2. If a single stage thermostat is used it should be connected to terminals R and W1 and a jumper wire installed from terminals W1 to W2 (see enclosed control circuit wiring diagram). Some models of furnace have the 24 VAC power available between terminal C and R for use with external air conditioning relay option. Never short or cross these two terminals! The transformer will fail.

OPERATION

When control thermostat is turned up to demand heat the blower and heating elements should be energized. Furnaces with sequences installed will have up to 30 seconds delay in start-up. When turned to cool position heat-cool thermostats should bring on the blower only for air only.

MAINTENANCE

"CAUTION" Disconnect power at the main service panel before inspecting or cleaning this heater. Lock or Tag breaker to prevent accidental shock.

Because of its rugged design, superior engineering and quality craftsmanship the King KFUH Unit Heater requires little maintenance. With minimum care your electric heater should last a lifetime. King recommends changing the air intake filter at least twice a year and checking the motor and blower for excessive dust / lint accumulation to maintain the efficiency of the heater. While King recommends the filter be changed twice a year, your environment may require more frequent changes.

WARRANTY

The King KFUH unit heater is warranted against defects in workmanship and materials for five years from date of installation. Extended warranty applies to heating element only; all other components are covered for two years. This warranty does not apply to damage from accident, misuse or alteration; nor where the connected voltage is more than 5% above the nameplate voltage; nor to equipment improperly installed, wired or maintained in violation of this instruction sheet. All claims for warranty work must be accompanied by proof of the date of installation. The customer shall be responsible for all costs incurred in the removal or reinstallation of products, including labor costs, and shipping costs incurred to return products to King Manufacturing. King, will repair or replace, at our option, at no charge to you with return freight paid by King. King shall not be liable for consequential damages arising with respect to the product, whether based upon negligence, tort, strict liability or contract. No other written or oral warranty applies, nor any warranties by Representatives, Dealers, Employees of King or any other person. King Manufacturing can be contacted in Seattle, Washington U.S.A. by phone at (206) 762-0400, fax (206) 763-7738 or website www.king-electric.com.

TROUBLESHOOTER		
TROUBLE	POSSIBLE CAUSE	REMEDY
Unit will not start	<ul style="list-style-type: none"> • Thermostat wire is not connected • Circuit breaker is off • 24 Volt transformer burned out • Wire connection off or there are broken wires • Reset button tripped • Wrong voltage 	<ul style="list-style-type: none"> • Repair • Reset • Replace • Repair or replace • Reset • Check the power source
Motor will not stop	<ul style="list-style-type: none"> • Defective sequencer or contactor 	<ul style="list-style-type: none"> • Replace
Unit goes off on high limit	<ul style="list-style-type: none"> • Dirty air filter • Defective sequencer • Defective limit control • Power failure 	<ul style="list-style-type: none"> • Replace • Replace • Replace • Reset manual limit push button 20-35 kW units
Vibration noise	<ul style="list-style-type: none"> • Blower assembly loose 	<ul style="list-style-type: none"> • Secure blower and motor cage
Unit has a buzzing sound when not in use	<ul style="list-style-type: none"> • Low voltage transformer defective or loose 	<ul style="list-style-type: none"> • Replace or tighten
Unit continues to heat after room is up to set temperature - does not shut off	<ul style="list-style-type: none"> • Defective sequencer • Defective thermostat • Thermostat wires to ground • Motor wires to ground • Thermostat accidentally shorted & contacts are welded 	<ul style="list-style-type: none"> • Replace • Replace • Repair • Repair • Replace - Make sure all connections are tight

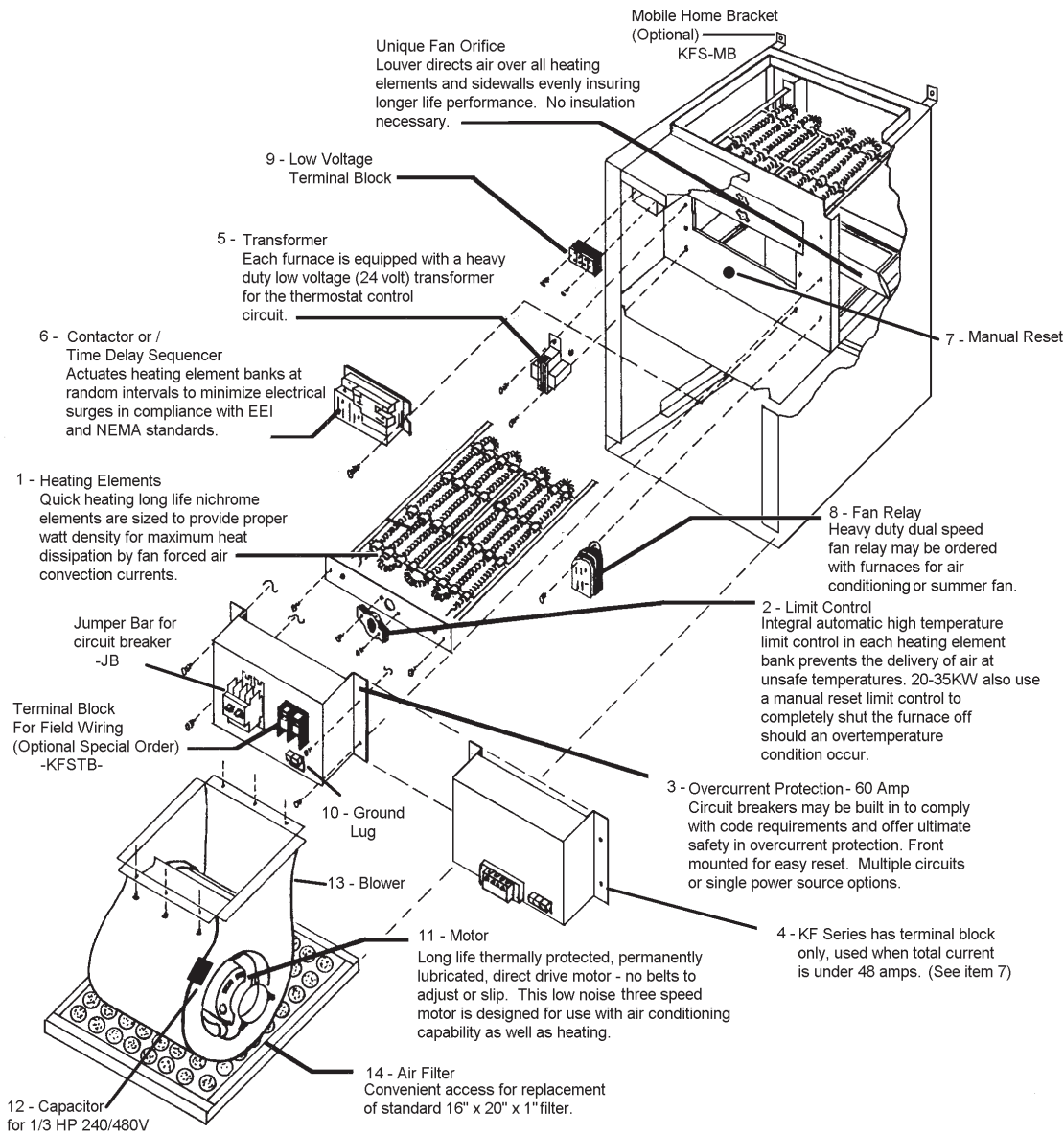

ITEM PART NUMBER DESCRIPTION

1	21-2405-00	Heating Element	5 kW / 240V
	21-2405-07	Heating Element	5 kW / 208V
	21-2405-9	Heating Element	5 kW / 480V
	21-2405-2	Heating Element	5.75 kW / 240V
	21-2405-12	Heating Element	5.75 kW / 240V
	21-2405-1	Heating Element	4 kW / 240V
	21-2405-6	Heating Element	4 kW / 480V
	21-3413-00	Heating Element - 3 Ph	5 kW / 240V
21-3413-01	Heating Element - 3 Ph	5 kW / 480V	
2	60T11-201936	Auto. Limit Control - 60T11	
3	QOU260	Circuit Breaker 60 Amp - 1 Ph Square D	
	QOU360	Circuit Breaker 60 Amp - 1 Ph Square D	
4	EB-200	Input Terminal Block - 1 Ph, 2P, 240V	
	ED-2	Input Terminal Block - 1 Ph, 2P, 480V	
	ERB-201	Input Terminal Block - 3 Ph, 3P, 240V	
	ED-3	Input Terminal Block - 3 Ph, 3P, 480V	
5	4000-09-E07K999	Low Volt Transformer 240 / 208	
	4000-03-E07J999	Low Volt Transformer 277 / 24	
	4000-04-E07K999	Low Volt Transformer 480 / 24	

6	R8330	Sequencer (used prior to 1981)
	15SH22-30956	Sequencer (used after 1981)
	R8229A	Relay 28 Amp
	R8246A	Relay 46 Amp
7	60T25-330976	Manual Reset Limit
	10935H3	Manual Reset Button
8	9100233Q999	Dual Speed Fan Relay
9	ELD-5-034	Low Voltage Terminal Block
10	CA4SP	Ground Lug
11	5KSP39FGW057AS	1/5 HP 240V Motor
	5KSP39FGW244AS	1/5 HP 480V Motor
	5KCP39MGE250AS	1/3 HP 240V Motor
	5KSP39FGG136S	1/3 HP 480V Motor
	4M207G	1/2 HP 240V Motor
	5KCP39M6J185S	1/2 HP 480V Motor
12	DAO-3GJ005	Capacitor 3MP 370V
	DAO-3GJ007.5	Capacitor 7.5MF 370V
	DAO-3GJ010	Capacitor 10MF 370V
13	FURNACE BLOWER SMALL	Blower Small for 1/5 HP Motors
	FURNACE BLOWER LARGE	Blower Large for 1/3, 1/2 HP Motors
	120-8T-DD-.50PP	Blower X-Large for 1/2 HP Motors
14		Air Filter 1" x 16" x 20"

Tools used for testing.

Extech 407736 Sound Level Meter. Accuracy: 1.5dB+ -
Calibrated for test and using A weighted and slow response to
get overall sound readings. Ambient sound at 41 dB.

Note: KFUH2410 was Wired on low speed fan at 775 CFM.
Cabinet outlet has duct liner for sound absorption.

Inlet Sound levels:

3ft: 53db
6ft: 50dB
10ft: 49dB



Side Sound levels:

3ft: 51db
6ft: 51dB
10ft: 49dB

Outlet Sound levels:

3ft: 58db
6ft: 53dB
10ft: 49dB

Cabinet door Sound levels:

3ft: 53db
6ft: 50dB
10ft: 49dB



9131 10th Ave So.
Seattle WA 98108

Phone:206-760-0400 Fax: 206-763-7738

KFUH2410 Sound Level Testing

Performed by: Brad Wilson Date: 4/7/05