



Architectural Heater KAWH Series



Model Code:

KAWH	20	20
A	B	C
A: Series		
B: 20 - 208V 24 - 240/208V 27 - 277V 48 - 480V		
C: Watts (1125 to 8000)		
D: Grill Color		
E: Control Options		
F: Mounting Box		



- Tubular Element with fins
- Factory-lubricated Motor
- Smart Limit Protection®
- Bottom air outlet
- Extruded aluminum grill
- Standard color: bright white
- 10" minimum clearance
- 160 CFM fan
- 208, 240/208, 277, 347, 480 or 600 Volts
- Built-in tamperproof thermostat
- Standard 140°F wiring
- 1-year warranty against defects

The Architectural Heater

The KAWH provides heavy duty elegance. in an architectural heater and quick heat in areas affected by cold drafts. Its corrosion-resistant aluminum front is offered in several colors. The appearance of the overall finish will not change over time. The control is hidden to avoid tampering. Powered by a closed factory lubricated motor, the fan blows warm air downward to create air circulation. Excellent for use in apartment complexes, commercial buildings, entryways, stairwells or garages.

Ordering Information

*Add suffix -A for optional Almond color

MODEL	UPC	VOLTS	WATTS	AMPS	SHIP WEIGHT lbs
KAWH2020	30800	208	2000	9.6	24
KAWH2040	30802	208	4000	19.2	24
KAWH2048	30804	208	4800	23.07	24
KAWH2080*	30806	208	8000	38.46	50
KAWH2415	30808	240/208	1500/1125	6.25/5.4	24
KAWH2420	30810	240/208	2000/1500	8.3/7.2	24
KAWH2430	30812	240/208	3000/2250	12.5/10.8	24
KAWH2440	30814	240/208	4000/3000	16.6/14.4	24
KAWH2448	30816	240/208	4800/3600	20.0/17.3	24
KAWH2460*	30818	240/208	6000/4500	25.0/21.6	50
KAWH2480*	30820	240/208	8000/6000	33.3/25.0	50
KAWH2715	30822	277	1500	5.4	24
KAWH2720	30824	277	2000	7.2	24
KAWH2730	30826	277	3000	10.8	24
KAWH2740	30828	277	4000	14.4	24
KAWH2748	30830	277	4800	17.3	24
KAWH2760*	30832	277	6000	21.6	50
KAWH2780*	30834	277	8000	28.8	50
KAWH4815	30836	480	1500	3.1	28
KAWH4820	30838	480	2000	4.1	28
KAWH4830	30840	480	3000	6.2	28
KAWH4840	30842	480	4000	8.3	28
KAWH4848	30844	480	4800	10.0	28
KAWH4860*	30846	480	6000	12.5	50
KAWH4815*	30848	480	8000	16.6	50

Single unit width 16 1/8" *Denotes double unit (31 7/8" W)

Architectural Heater KAWH Series

Engineering Specifications

Contractor shall supply and install KAWH Series in-wall mounted forced-air electric heaters by King Electrical Mfg. Company, of the wattage and voltage as indicated on the plans.

Motor: Closed, factory-lubricated motor.

Fan: 160 cfm fan (1.5 to 4.8 kW); 2 160 cfm fan (6 to 8 kW)

Thermostat: Built-in tamperproof thermostat included (32°F - 120°F)

Elements: Durable tubular heating element with fins.

Thermal Overload: High-limit temperature control with automatic reset.

Fan / Heat / Off Switch: Fan delay purges heater of residual heat (Any remote thermostat or relay must be connected to the heater control terminal block.)

Wall-box: Minimum clearance from the floor and adjacent walls: 10".

Grill: Extruded aluminum front grille, 1/8" thick.

Options: Wired for remote thermostat, and surface wall-box.

Approvals: cCSAus

Dimensional Data

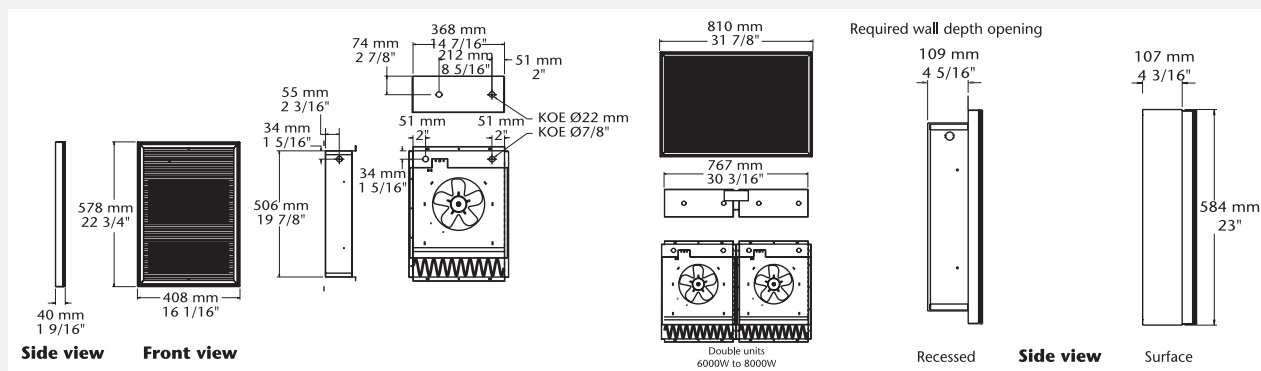

Options

ADD SUFFIX	DESCRIPTION
-BW	White Color
-AM	Almond Color
-NL	Semi-Gloss Black (10% upcharge applies)
-AE	Metallic Silver (10% upcharge applies)
-BZ	Bronze Color (10% upcharge applies)
-CM	Metallic Charcoal Color (10% upcharge applies)
-AL	Aluminum (10% upcharge applies)
-SA	Sand (10% upcharge applies)

Control Options

*Thermostat is not INSTALLED IN HEATER WITH FACTORY INSTALLED RELAY OPTIONS

MODEL	DESCRIPTION
Product no-RT*	Factory Installed 24V Relay with Transformer
Product no-R*	Factory Installed 24V Relay without Transformer
KAWH-DIS20	Factory Installed Disconnect Switch 277V & Less Double Pole 20A
KAWH-DIS40	Factory Installed Disconnect Switch 600V Max. Three Pole 40A
KAWH-IV	Factory Installed Fan Switch

Accessories

MODEL	DESCRIPTION
KAWH-BSA	Surface Mounting Box -1500W to 4800W
KAWH-BSA2	Surface Mounting Box -6000W to 8000W