

Installation, Operation and Maintenance Instructions

IMPORTANT: Save These Instructions!



Item	Qty	Description
A	2	Warning labels for pipe trace
B	2	Warning labels for gutter ice melt.
C	2	Cable ties
D	1	Black heat shrink tube (1" dia. x 8" length)
E	2	Mastic strips (1" width x 1-1/2" length)
G	1	Black heat shrink tube (1/2" dia. x 1" length)
H	2	Black heat shrink tube (1/8" dia. x 1" length)
I	2	Insulated bus wire crimp connectors
J	1	Un-insulated ground braid crimp connector
K	2	Black cloth tape (1" width x 6" length)
X	1	Black heat shrink tube (3/4" dia. x 5" length)
Y	1	Woven braid sleeve (1/2" dia. x 4" length)
Z	1	Black heat shrink cap (1/2" dia. x 1-1/4" length)

DESCRIPTION:

SR self-regulating heating cables are designed for a variety of pipe freeze protection as well as roof and gutter deicing applications. The heat output (wattage) increases and decreases based on the temperature, so the cable adjusts automatically to varying climate conditions. This unique feature ensures maximum energy efficiency by increasing the heat output only when it is needed. No thermostat is required.



DESCRIPTION

The SRK08 GEFP plug-in power connection kit is to be used with King SR self regulating heating cables only. The kits are not approved to be used with other brands of heating cable. The kit contains enough material for making one 120 volt plug-in power connection and one end seal. King SR cables are approved for both pipe freeze protection and roof and gutter deicing applications. The kit is to be used with copper wire only, do not use aluminum power supply wires

ADDITIONAL MATERIALS REQUIRED

- UL Listed weatherproof junction box when used outdoors with a weatherproof cover for the plug.
- The junction box requires a 120 volt receptacle for the GFCI device to plug into.
- For heating cable with no outer-jacket, a metallic junction box must be used to ensure proper grounding.
- The application may require additional accessories; for example, SRK03 application tape for pipe applications or SRK13 roof clips and/or SRK15 downspout hangers for roof and gutter deicing.

TOOLS REQUIRED

- Adjustable wrench or pliers, needle nose pliers, diagonal cutters, utility knife, screwdriver, propane torch or heat gun, crimp tool.

WARNING

Fire and shock hazard. Improperly installed heating cable can cause electrical shock, arcing, and fire. Carefully follow all the instructions provided read the cautions and warnings.

1. Heating cables must be installed in compliance with the national electric code (NEC) in addition to state, provincial and local codes. Check with your local inspector for specific code requirements (or regulations or standards) in your area.
2. Save these instructions and transfer them to future owner(s).
3. Never install on pipes that could potentially exceed 150° F, (65° C).
4. Do not substitute components or use or use vinyl electrical tape.
5. Not for use with indoor pipes. Cable should not run through the building walls, ceilings or floors.
6. For safety, King recommends that all heating cables are placed on a Ground Fault Equipment Protection (GFCI) circuit. Consult your local electrical inspector to determine the specific requirements in your area.
7. The black heating core is conductive and can short. It must be properly insulated with heat shrink tubing.
8. Keep components and heating cable ends dry during installation.
9. Damaged bus wires can overheat or cause an electrical short. Do not energize cable if the bus wires are damaged.
10. Do not break the braid or bus wire strands when stripping the jacket or conductive core.
11. Bus wires will short if they come in contact with each other. Never splice the bus wires together, they must remain separate.
12. Heat-damaged components can short, the use a heat gun is preferred. Use a torch with a soft, yellow, low-heat flame, not a high heat blue focused flame. Keep the flame moving to avoid overheating, blistering, or charring the heat-shrinkable tubes. Avoid heating other components and replace any heat damaged parts prior to energizing the cable.
13. Use only fire-resistant insulation materials such as fiberglass wrap.
14. Do not twist the cable during installation.
15. De-energize all supply power circuits before installation or servicing.
16. Do not embed the heating cable.
17. Post warning labels supplied with the cable at the power supply and along the pipe on the outside of the insulation.
18. Do not bend the cable to less than a 1/2" radius.
19. Do not install cable on shingle roofs in freezing temperatures; as this may cause damage to the shingles.
20. Cables are intended for freeze protection of water pipes only. Not intended for use with other liquids or hazardous materials.
21. Install cable in accessible areas only.

Caution: Charring or burning the heat-shrinkable tubes in this kit can produce fumes that may cause eye, shin, nose, and throat irritation. Ensure proper ventilation during installation to minimize this health risk.

Important: For the warranty to be valid, installer must comply with all requirements outlined in these guidelines. All design information provided here is based upon a standard installation with heating cable fastened to an insulated pipe.

Electrical codes: Article 427 of the National Electrical Code and Section 62 of CAN/CSA-C22.1, Canadian Electrical Code govern the installation of King SR heating cable for pipe freeze protection.

SR Heating Cable Selection and Design

Use table 1 to select the heating cable size for insulated **metal** pipes and use table 2 to select heating cables for insulated **plastic** pipes. Read across the table to find the pipe size, then drop down the column to the row corresponding to the lowest design air temperature column for the application and chose the thickness of the insulation that will be used. The cell that intersects will give the power (watts/ft.) of the cable required and it may also have a number (2) in the cell which represents using 2 cables. Run the cable straight along the bottom of the pipe. If two cables are required, attach them at the 4 and 8 o'clock positions as shown in figure 1 page 4. Spiral tracing the cable is not recommended as it is labor intensive.

Table 1' – SR cable selection for metal pipes (w/ft.)

Lowest Air Temp.	Insulation Thickness	1/2"	3/4"	1"	1-1/4"	1-1/2"	2"	2-1/2"	3"	4"	6"	8"
0°F (-18°C)	1/2"	3	3	3	3	5	5	5	5	8	8	10
	1"	3	3	3	3	3	3	3	5	5	8	8
	1-1/2"	3	3	3	3	3	3	3	3	5	5	5
	2"	3	3	3	3	3	3	3	3	3	5	5
-20°F (-29°C)	1/2"	3	5	5	5	5	5	8	8	10	10	*
	1"	3	3	3	3	3	5	5	5	8	8	10
	1-1/2"	3	3	3	3	3	3	3	5	5	8	8
	2"	3	3	3	3	3	3	3	3	5	5	8
-40°F (-30°C)	1/2"	5	5	5	5	8	8	10	(2) 8	(2) 8	(2) 10	*
	1"	3	3	3	5	5	5	8	8	8	10	(2) 8
	1-1/2"	3	3	3	3	3	5	5	5	8	8	10
	2"	3	3	3	3	3	3	3	5	5	8	8
	3"	3	3	3	3	3	3	3	3	3	5	5

Table 2' – SR cable selection for plastic pipes (w/ft.)

Lowest Air Temp.	Insulation Thickness	1/2"	3/4"	1"	1-1/4"	1-1/2"	2"	2-1/2"	3"	4"	6"	8"
0°F (-18°C)	1/2"	3	5	5	5	8	8	8	10	(2) 8	(2) 10	*
	1"	3	3	3	5	5	5	5	5	5	8	8
	1-1/2"	3	3	3	3	3	3	5	8	8	8	10
	2"	3	3	3	3	3	3	3	5	5	8	8
-20°F (-29°C)	1/2"	5	5	8	8	10	10	(2) 8	(2) 8	(2) 10	*	*
	1"	3	3	5	5	5	8	8	8	10	(2) 8	(2) 10
	1-1/2"	5	5	5	5	5	5	5	8	8	10	(2) 8
	2"	3	3	3	3	3	5	5	5	8	8	10
-40°F (-30°C)	1/2"	8	8	8	8	10	10	(2) 8	(2) 10	*	*	*
	1"	5	5	5	8	8	8	10	10	(2) 8	*	*
	1-1/2"	5	5	5	5	5	8	8	8	10	(2) 8	(2) 10
	2"	5	5	5	5	5	5	5	8	8	10	(2) 8
	3"	3	3	5	5	5	5	5	5	5	8	10

† The tables are based on using fiberglass insulation or equivalent while maintaining a 40°F (4°C) pipe temperature with a 10% safety factor and 20 mph wind speed.

* Contact King for the proper cable selection

Circuit Breaker Protection and Cable Length Design for Pipe Freeze Protection

The maximum length of a single cable run is noted in Table 3 and cannot be exceeded. If the application requires a longer cable run, then multiple cables and additional power circuits must be used.

Circuit protection depends on the length of cable required and the start-up temperature since the cable will draw more power (wattage) when cold. Multiple cables can be run from a single power circuit up to a maximum combined length as noted in Table 5. Larger amperage circuit breakers can handle longer combined cable lengths, but the maximum length for a single cable run does not change. The NEC requires the use of ground fault protection breakers for heating cable.

Table 3: Maximum Single Cable Length

Model	Volts	Watt/ft	Maximum Single Run Length
SR123	120V	3 w/ft	325 ft. (99M)
SR125	120V	5 w/ft	270 ft. (82M)
SR128	120V	8 w/ft	210 ft. (64M)
SR1210	120V	10 w/ft	180 ft. (55M)

Table 5: Circuit Protection Per Combined Cable Length for Pipe Freeze Protection

Volts	Start up Temp.	Circuit Breaker*	SR123 3w/ft.	SR125 5w/ft.	SR128 8w/ft.	SR1210 10w/ft.
120 V	50°F (10°C)	15 Amp	325 ft. (99M)	225 ft. (69M)	145 ft. (44M)	115 ft. (35M)
		20 Amp	435 ft. (133M)	270 ft. (82M)	195 ft. (59M)	150 ft. (46M)
	0°F (-18°C)	15 Amp	230 ft. (70M)	155 ft. (47M)	100 ft. (30M)	85 ft. (26M)
		20 Amp	305 ft. (93M)	205 ft. (72M)	130 ft. (40M)	110 ft. (34M)
	-20°F (-29°C)	15 Amp	205 ft. (63M)	135 ft. (41M)	90 ft. (27M)	75 ft. (23M)
		20 Amp	275 ft. (84M)	180 ft. (55M)	115 ft. (35M)	100 ft. (30M)

SR Heating Cable Selection and Design (continued)

CALCULATE THE TOTAL HEATING CABLE LENGTH

Cable length = A+B+C+D+E+F

- A Pipe length x number of cables
 - B 4 ft. x number of valves
 - C 2 ft. x number of flanges, supports, etc.
 - D 1 ft. for each power connection
 - E 2 ft. for each splice connection
 - F 3 ft. for each tee connection
- = Total heating cable length (ft)

MAXIMUM CIRCUIT LENGTH ALLOWED

Ensure that your circuits do not exceed the maximum circuit length listed in Table 3, page 4. If necessary, use additional shorter circuits.

EXAMPLE

Pipe size: 2" metal pipe
 Lowest air temp: -20° F
 Insulation thickness: 1"
 Cable selection: (1) 5w/ft. (From table 1, pg 3)
 Pipe length: 80 ft.
 Valves: 2
 Pipe supports: 12
 Power connections: 1
 Splice connections: 1

HEATING CABLE REQUIRED

A	Pipe length x number of cables	80 ft. x 1 = 80 ft.
B	4 ft. x number of valves	4 ft. x 2 = 8 ft.
C	2 ft. x number of flanges, supports, etc.	2 ft. x 12 = 24 ft.
D	1 ft. for each power connection	1 ft. x 1 = 1 ft.
E	2 ft. for each splice connection.	1 ft. x 1 = 1 ft.
F	3 ft. for each tee connection	3 ft. x 0 = 0 ft.
=	Total heating cable length (ft)	114 ft.

Heating Cable Installation

GENERAL NOTES

1. Verify that the heating cable is the correct length, wattage and voltage prior to installation.
2. All welding, hydrostatic testing, and painting of the pipe should be completed before the heating cable installation.
3. The piping system must be inspected to ensure that it is clean, dry and has no sharp or jagged edges that could potentially damage the heating cable.
4. Do not install the heat tracing before completion of the entire piping system.
5. The cables must be installed a minimum of 10 inches away from wood or any other combustible materials.
6. The minimum cable bending radius is 1/2 inch.

STEP 1: PREPARE FOR INSTALLATION

1. Store the heating cable in a clean, dry place.
2. Perform a pressure test on the pipe prior to cable installation.
3. Remove any sharp surfaces on the pipe that could potentially damage the outer jacket of the heating cable.
4. Walk the pipe system and plan the routing of the heating cable on the pipe.

STEP2: CUT THE HEATING CABLE TO LENGTH

1. Cut the heating cable to length required. This can be done before or after the cable is attached to the pipe.
2. Leave a minimum of 1 foot extra heating cable for connection to the supply power.
3. For splice and tee connections, leave a minimum of 1 foot for each section of heating cable.
4. King SR heating cable can to length without affecting its heat output per foot.
5. When splicing and terminating be sure to protect the cable ends from moisture, contaminants and mechanical damage.

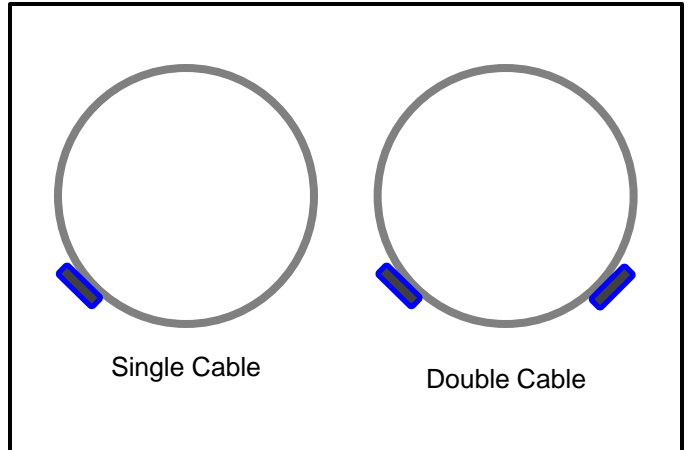

Figure 1: Cable Placement on Pipe

STEP 3: ATTACH THE CABLE TO THE PIPE

1. Verify pipe to be traced is completely dry.
2. For straight tracing, install the heating cable on a the lower half of the pipe; for example, in the 4 o'clock or 8 o'clock position as shown in Figure 1.
3. Install the extra heating cable as required for valves, flanges, etc.
4. Spiral tracing is not recommended as it is labor intensive.
5. If applying spiral tracing, begin by suspending a loop of cable every 10 feet as shown. To determine the loop length, divide the length of pipe length and multiply by 10.
6. Fasten the heating cable to the pipe at 2 foot intervals using SRK03 fiberglass tape or nylon cable ties. Do not use vinyl electrical tape, duct tape, metal bands or wire.
7. If there is excess cable at the end of the pipe, double remaining cable back along the pipe.

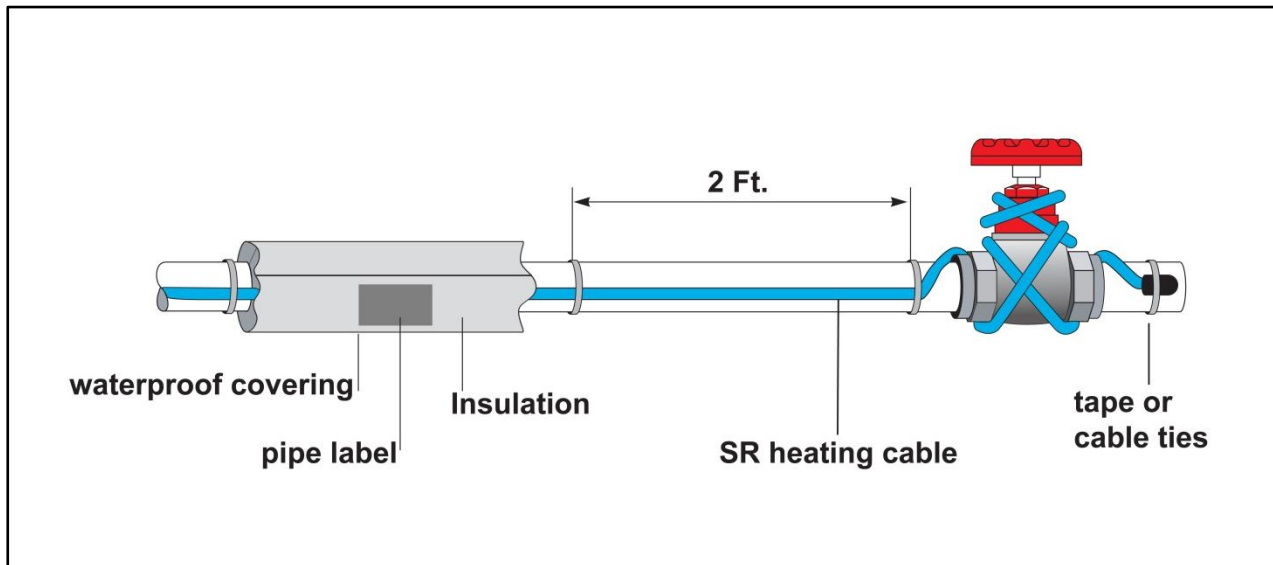

Figure 2: SR Cable installation for Pipe Freeze Protection

Heating Cable Installation (continued)

STEP 4: INSTALL ACCESSORIES KITS

1. Install heating cable end seals, splices, tees, and power connection prior to energizing cable.
2. Use only the SR00 power connection kit, SRK10 splice and tee kit, SRK08 GFCI power connection kit and SRK 12 end seal kit.

STEP 5: CHECK FOR PROPER INSTALLATION

1. Before installing the thermal insulation, inspect the heating cable to verify damage did not incur during installation including any thermal damage or other disturbance which may have occurred if exposed to a excessive heat.
2. Visually inspect all power connections, end seals, splices and tee connections.

STEP 6: INSTALL THE THERMAL INSULATION

1. The heat trace system requires weatherproofed thermal insulation installed as shown in Figure 32.
2. A minimum of at least 1/2" of preformed foam or equivalent thermal insulation must be used on all piping, including valves, joints, and wall penetrations.
3. Install the insulation on the piping as soon as possible to minimize the potential for mechanical damage after installation.

STEP 7: FASTEN LABELS

1. Place caution labels so they are visible on the outside of the thermal insulation at 10 ft intervals on alternating sides of the pipe to indicate the presence of the electric heating cable system. Additional labels and fiberglass tape are available in SRK03 kit.

STEP 8: STARTING THE HEATING CABLE SYSTEM

1. Test per the "cable testing and maintenance" section.
2. Check the circuit breaker to verify there is power to the cable.
3. Check standing water in the pipe after one hour, it should feel warm.

STEP 9: CABLE TESTING AND MAINTENANCE

1. Using a 2500-volts DC megohmmeter, check the resistance between both of the power prongs on the plug and the ground prong after installing the heating cable. Minimum reading should be 1000 megohms.
2. Record the original values for each circuit, and compare subsequent readings taken during regular maintenance to the original values.
3. If the readings fall below 1000 megohms, replace with a new cable or repair with the proper SRK accessory kit.

⚠️ WARNING

Fire and shock hazard. Damaged heating cable can cause electrical shock, arcing, and fire. Do not energize a damaged heating cable. Immediately replace the cable or repair it with the proper SRK accessory kit.

SR Heating Cable Design for Roof and Gutter Applications

GENERAL INFORMATION

- SR cable is designed to remove ice, not accumulated snow.
- SR cable will not keep snow or ice from falling off of the roof. Snow fences or snow guards should be used to eliminate snow movement.
- SR heating cables may be used on:
 - Roofs made from all types of roofing materials, such as shake, shingle, rubber, tar, wood, metal, and plastic.
 - Gutters made from standard materials, such as metal and plastic.
 - Downspouts made from standard materials, such as metal and plastic.
- Do not install the heating cable underneath any roof covering.
- Install only in accessible locations; do not install behind walls or where the cable would be hidden.
- Do not run the heating cable through walls, ceilings, or floors.
- Connect only to ground-fault protected circuit breakers or outlets that have been installed in accordance with all national and local codes and standards and that are protected from rain and other water sources such as melting ice water.
- Do not exceed the amp rating of the over current protection device.

Selecting the Required Heating Cable Length for Roof and Gutter Deicing

CALCULATION FOR HEATING CABLE LENGTH:

Use the formula below to determine the amount of heating cable required.

Total heating cable length = A+B+C+D+E+F+G

- A** (Roof edge) × (heating cable multiplier)
- B** (Roof edge × 0.5)
- C** (Total gutter length)
- D** (Total downspout length + 1 ft)
- E** (1 ft for each power connection)
- F** (2 ft for each splice)
- G** (3 ft for each tee connection)
- = Total heating cable length required

Example:

- Roof edge = 48 ft
- Eave overhang = 1 ft (Refer to Table 6)
- Gutter = 48 ft
- Downspout = 22 ft
- Power connection = 2 each
- Splice = 3 each

Heating Cable Required:

A Roof edge:	48 ft × 2.8 (From table 6)	= 134.4 ft
B Roof extension*:	48 ft × 0.5	= 24.0 ft
C Roof gutter:	48 ft	= 48.0 ft
D Downspout:	22 ft + 1 ft	= 23.0 ft
E Power Connection:	2 × 1 ft	= 3.0 ft
F Splice Connection:	3 × 2 ft	= 6.0 ft
G Tee Connection:	0 × 3 ft	= 0.0 ft
Total heating cable length required:		= 238.4 ft

*Roof extension is the length of cable required to prevent ice dams between the roof edge and the gutter. When there are no gutters present it forms a drip loop to prevent ice dams at the roof edge.

Eave Overhang	Standard Roof	Metal Roof 18" Seam	Metal Roof 24" Seam
None	2.0	2.5	2.0
12"	2.8	2.8	2.4
24"	3.8	3.6	2.9
36"	4.8	4.3	3.6

Table 6: Heating Cable Multiplier

Use the number in the table and multiply it by the length of the roof edge.

CALCULATIONS FOR GUTTERS, DOWNSPOUT AND VALLEYS:

- For standard non-metal roofs, add 1 foot of heating cable for each foot of gutter.
- Add 1 foot of heating cable per foot of downspout.
- If the downspout is in the middle of the run, loop the cable down and back up. Double the length of the downspout for determining the length of cable to install.
- For valleys, run the heating cable two thirds of the way up and down the valley. Add this additional length to the overall cable needed.
- For gutters 6 inches wide use two cable runs.

DESIGN NOTES:

- In-line splices and tee splices should be avoided where possible.
- Heating cable in downspouts should be looped and extend below the frost line if tied into a drainage system.
- End terminations should not be located in an area where moisture is present. End terminations should not be located at the lowest point of downspouts.
- For roof drains leading into a heated area, a loop of heating cable should be installed to a depth of 3 ft.

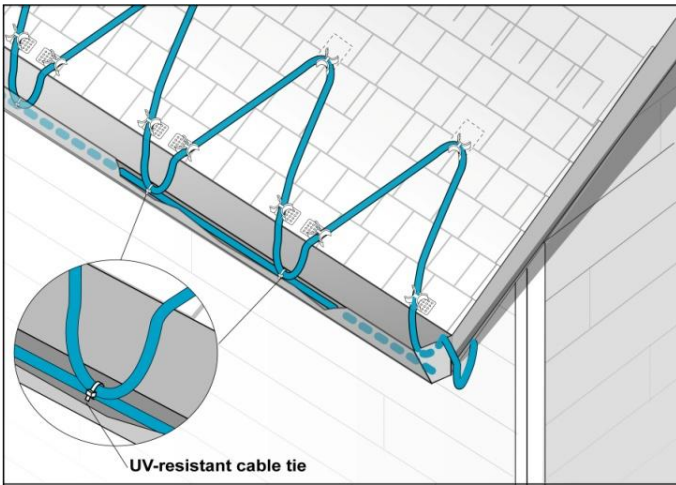

Figure 3: Shake and Shingle Roof Attachment

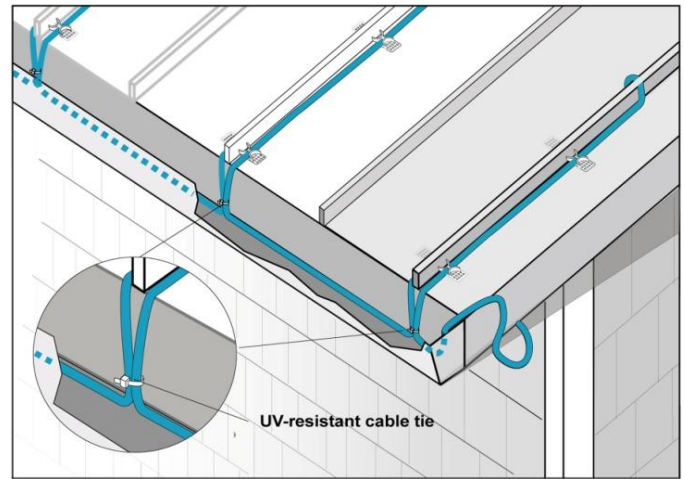

Figure 4: Metal Roof Attachment

Eave overhang	Tracing width	Tracing height	Cable/roof edge
None	24"	18"	2.0 ft
12"	24"	18"	2.8 ft
24"	24"	30"	3.8 ft
36"	24"	42"	4.8 ft

Table 7: Tracing Heights for Shake and Shingle Roof

The last column gives the amount of cable required per foot of roof edge for standard shake and shingle roof (table 7) or a metal seam roof (table 8).

Eave overhang	Tracing width	Tracing height	Cable/roof edge
None	18"	18"	2.5 ft
12"	18"	24"	2.8 ft
24"	18"	36"	3.6 ft
36"	18"	48"	4.3 ft
None	24"	18"	2.0 ft
12"	24"	24"	2.4 ft
24"	24"	36"	2.9 ft
36"	24"	48"	3.6 ft

Table 8: Tracing Heights for Metal Seam Roof

Heating Cable Installation

PREPARE FOR INSTALLATION

1. Store the heating cable in a clean, dry place.
2. Inspect for any mechanical damage prior to installation.
3. Warranty is void if non-King accessories are used. King approved accessories include:
 - SRK00 Power connection kit
 - SRK03 Fiberglass tape and labels
 - SRK08 GFCI plug-in connection kit
 - SRK10 Splice and tee kit
 - SRK12 End seal kit
 - SRK13 Roof clips
 - SRK15 Downspout hanger bracket
4. Gutters and downspouts must be free of leaves and other debris.
5. Carefully plan the routing of the heating cable for roof and gutter deicing.
6. Inspected the mounting surface for sharp edges and remove as anything that could damage the cable.

STEP1: CUT THE HEATING CABLE TO LENGTH

1. Cut the heating cable to length required. This can be done before or after it is installed. Leave a minimum of 1 foot extra heating cable for power connection. For splice connections leave a minimum of 2 ft, and 3 ft for each tee connection.

STEP 2: ATTACH THE HEATING CABLE ON ROOFS

1. Loosely loop the heating cable on the roof at the overhang area. Pull the bottom of each heating cable loop over the roof edge and, using a UV-resistant cable tie as. Connect the bottom of each loop to the cable running in the gutter. This will ensure a drainage channel for the melting ice to drain off the roof and into the gutter and downspout. The cable in the gutter should remain against the bottom of the gutter as shown in Figure 3 (Standard Roof) and Figure 4 (Metal Roof).
2. Extend the top of each heating cable loop beyond where the wall joins the roof.
3. Use SRK13 roof clips to route heating cable up and down the edge of the roof according to the tracing height noted in the tables above and shown in Figures 6 and 7. Route the heating cable in such a way as to prevent abrasion to the cable jacket.

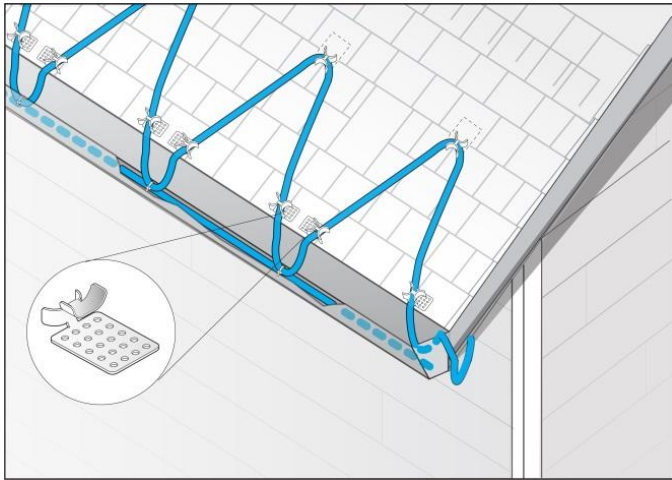

Figure 5: Roof Clip, Standard Shake Roof

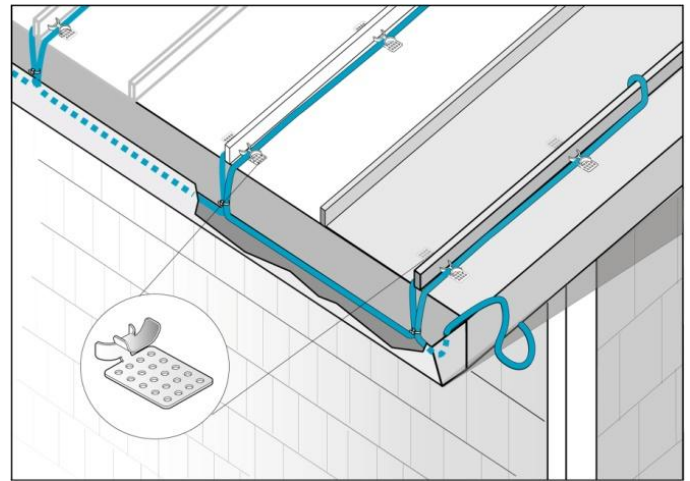

Figure 6: Roof Clip, Metal Roof

STEP 2 (continued)

4. One SRK13 kit contains 25 roof clips for approximately 17 linear feet of the roof edge.
5. Roof clips may be attached to a shake or shingle roof using nails or screws. Roof clips may be attached to a metal roof using nails, screws, or adhesive. Reseal the nail or screw holes if necessary before installing heating cable in the clips. See SRK13 installation instructions for additional details on mounting roof clips.
6. A barrier (snow fence) can be placed on the roof above the heating cable. This prevents damage to the cable and keeps the roof brackets from tearing loose during ice slides. The heating cable can be attached to the barrier with UV-resistant cable ties, instead of using roof clips. The use of other materials, such as wire, may cause damage to the heating cable and will void the warranty.

STEP 3: ATTACH THE HEATING CABLE ON VALLEYS

1. Trace two-thirds of the way up each valley with a double run of heating cable as shown in Figure 7.

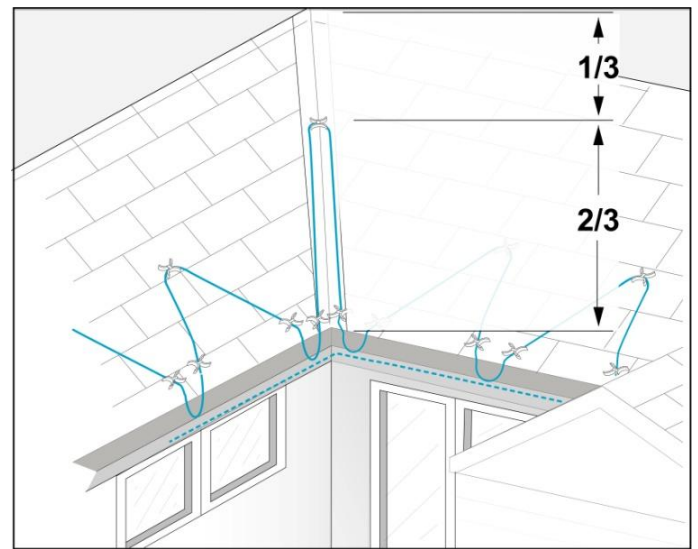

Figure 7: Roof Valleys

STEP 4: INSTALLING THE CABLE IN GUTTERS AND DOWNSPOUTS

1. Run the heating cable in the gutters and into downspouts, end the cable in a loop at the bottom of the downspout and then run the cable back up the downspout using a tie wraps to fasten it as shown in Figure 8. Permanent attachment of the cable to the gutter bottom is not necessary.
2. Use the King SRK15 downspout brackets at the transition of the gutter and downspout to protect the cable from fraying. Refer to the SRK15 installation instructions for more details.
3. Route and secure cable with care to avoid mechanical damage during installation or maintenance from such things as ladders, etc.

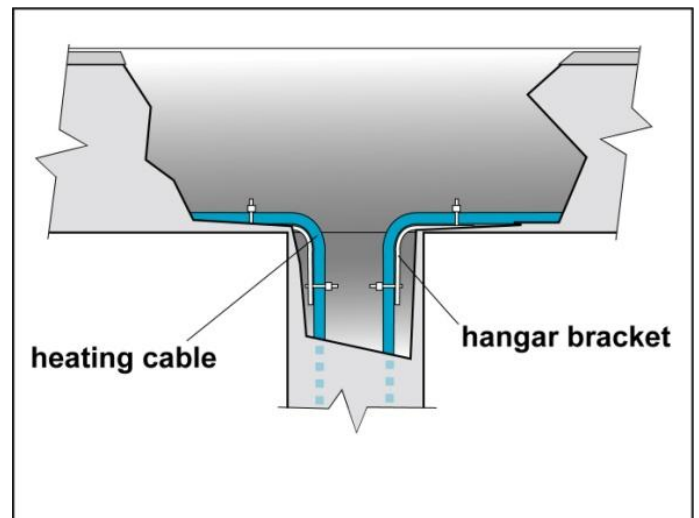

Figure 8: SRK15 Downspout Bracket

STEP 5: TERMINATING DOWNSPOUTS

1. The preferred method of installation is to run the heating cable into the downspouts, ending the cable in a loop at the bottom of the downspout and then run the cable back up the downspout into the gutter. This way there is no end seal in the downspout. For single cable runs in downspouts with an end seal use a tie wrap to fasten it as shown in Figure 9. Do not leave the end of the heating cable pointing down at the end of the downspout, double back as shown. Never create a situation where an end seal is positioned to be a drip point at the end of a cable run.

STEP 6: INSTALL END SEALS, SPLICES, TEES, AND POWER CONNECTION KITS

1. If installing a GFCI device on the cable the carefully follow the SRK08 installation instructions.
2. Use only listed weatherproof junction boxes approved for wet location when installing SR cable.
3. Use only listed watertight construction or enclosures, Type 3, 3s 4, 4X, 6, or 6P.
4. When possible, all power connection boxes should be located in a protected area (such as under eaves) and entry should be at the bottom of the box. In all case, a drip loop should be installed, do not let an end seal or splice or tee connection become a drip point.

STEP 7: ATTACH THE WARNING LABELS

1. Two warning labels are provided with the SR cable kit to indicate the presence of electric deicing and snow-melting equipment on the premises. One label should be attached at the electrical outlet cover and the other label must be posted at the fuse or circuit breaker panel feeding the outlet circuit. Labels must be clearly visible.

STEP 8: CHECK AND INSPECT THE INSTALLATION

1. Prior to powering the deicing cable into the outlet, check the entire length of the cable for mechanical damage such as nicks and cuts in the outer insulation and any potential thermal damage which may have occurred if cable was exposed to excessive heat.
2. Use a megohmmeter to test each circuit according to the instructions in the "Heating Cable Testing and Maintenance" section of these instructions.
3. Junction boxes should be inspected for water and for evidence of water damage. If moisture is present, the box should be restored to a dry condition and the cause of the water intrusion should be investigated and eliminated.
4. Test the ground fault circuit to be sure it is functioning properly. If malfunctioning, replace prior to energizing the system. Functionality of over-current protection devices such as circuit breakers or fuses should be checked as well.

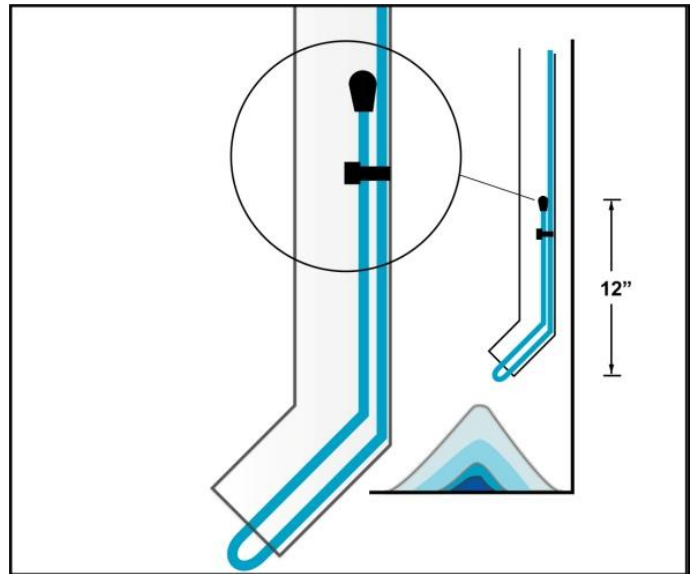

Figure 9: Downspout Termination

GROUND FAULT PROTECTION

National electrical codes require ground-fault equipment protection on each heating cable branch circuit. To reduce the risk of fire caused by damage or improper installation, circuit breakers with a 30-mA trip level are required. Alternative designs providing comparable levels of ground-fault protection may also be acceptable.

HEATING CABLE TESTING AND MAINTENANCE

1. Make sure that gutter and downspouts are free of leaves and other debris annually prior to the winter season.
2. Using a 2500-Vdc megohmmeter, check the resistance between both of the power prongs on the plug and the ground prong after installing the heating cable. Minimum reading should be 1000 megohms.
3. Record the original values for each circuit, and compare subsequent readings taken during regular maintenance to the original values.
4. If the readings fall below 1000 megohms, replace the cable with a new unit. Do not attempt to repair the cable.
5. Caution: Maintenance and repair of the heating cable system should only be performed by a qualified electrician.

WARNING

Fire and shock hazard. Damaged heating cable can cause electrical shock, arcing, and fire. Do not attempt to repair or energize damaged heating cable. If damaged, immediately repair or it and replace with a new cable.

Circuit Breaker Protection and Cable Length Design for Deicing

Table 9: Circuit Breaker Protection for Deicing

Cable	Volts	Start up Temp	15 Amp (ft.)	20 Amp (ft.)	30 Amp (ft.)	40 Amp (ft.)
SR123	120V	32°F (0°C)	273	273	273	273
		20°F (-7°C)	254	268	273	273
		0°F (-18°C)	213	255	273	273
		-20°F (-29°C)	182	248	273	273
SR125	120V	32°F (0°C)	188	216	216	216
		20°F (-7°C)	166	216	216	216
		0°F (-18°C)	144	193	216	216
		-20°F (-29°C)	127	173	216	216
SR128	120V	32°F (0°C)	126	168	171	171
		20°F (-7°C)	118	157	171	171
		0°F (-18°C)	103	136	171	171
		-20°F (-29°C)	92	123	168	171
SR1210	120V	32°F (0°C)	102	143	152	152
		20°F (-7°C)	97	126	152	152
		0°F (-18°C)	88	117	152	152
		-20°F (-29°C)	76	104	152	152

Table 10: Technical Data Ratings

Technical Data Table	
Maximum operating temp.	150°F (65°C)
Maximum exposure temp.	185°F (85°C)
Minimum installation temp.	0°F (-18°C)
Minimum bending radius	1", (24 mm)
Dimensions	.496" x .236" (12.6mm x 6mm)
Service voltage	110-120V, 208V-277V

Table 11: Maximum Single Run Length

Model	Volts	Output at 32°F (0°C)	Maximum Single Run Length
SR123	120V	5.0 w/ft	273 ft. (83M)
SR125	120V	8.0 w/ft	216 ft. (66M)
SR128	120V	12.1 w/ft	171 ft. (52M)
SR1210	120V	14.8 w/ft	152 ft. (46M)

Technical Data Notes:

1. The maximum single cable run is the longest length of heating cable before there is a significant voltage drop which will lower the wattage rating of the cable.
2. The circuit breaker sizes in Table 9 are per the National Electric Code (NEC).
3. The NEC requires ground-fault equipment protection (GFCI) for fixed outdoor deicing equipment. All electrical connections should be made by a licensed electrician.

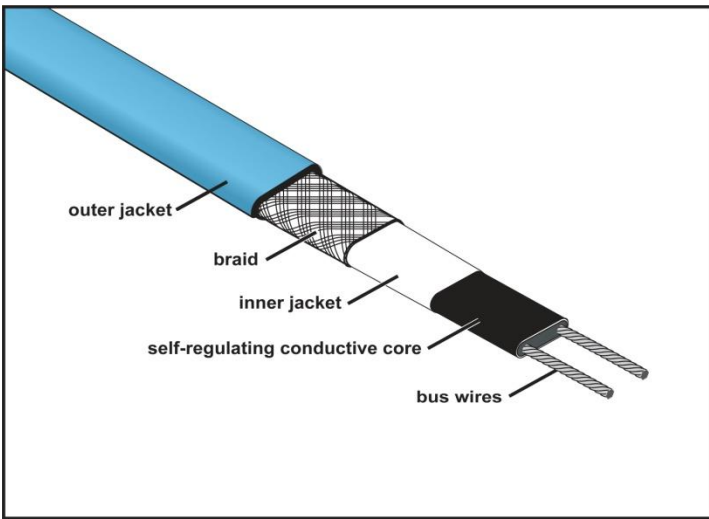

The SR heating cable is comprised of several layers as shown above, use the illustration to gain a clear understanding of the cable components.



1 Slide the 1" dia. x 8" long and the 1" dia. x 5" long black heat shrink tubes over the stripped end of the cord.

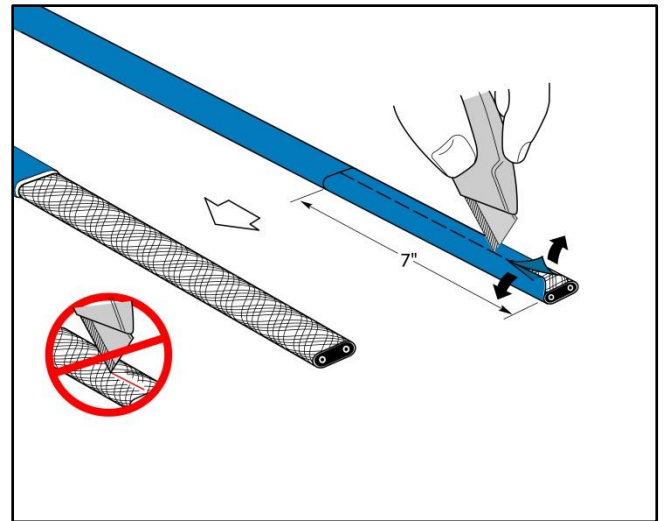

2 Lightly score completely around and then down outer jacket a distance of 7". Do not cut braid or inner jacket. Bend heating cable to break jacket at score, then peel off outer jacket!.

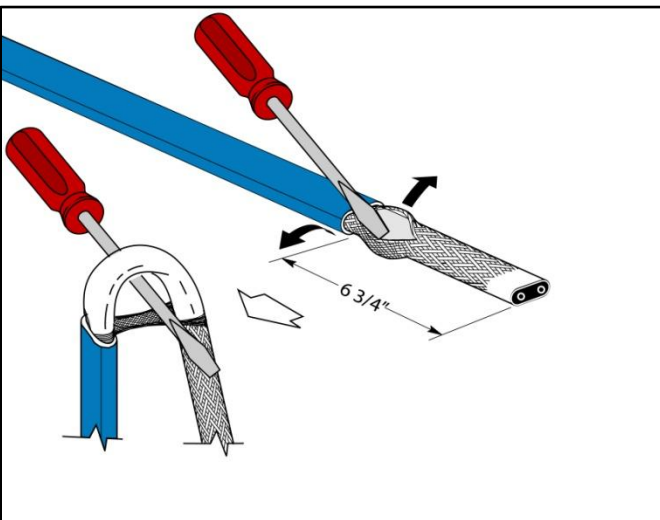

3 Cut the braid and push it back to loosen it as shown. Bend the cable and gently pull it through the braid.

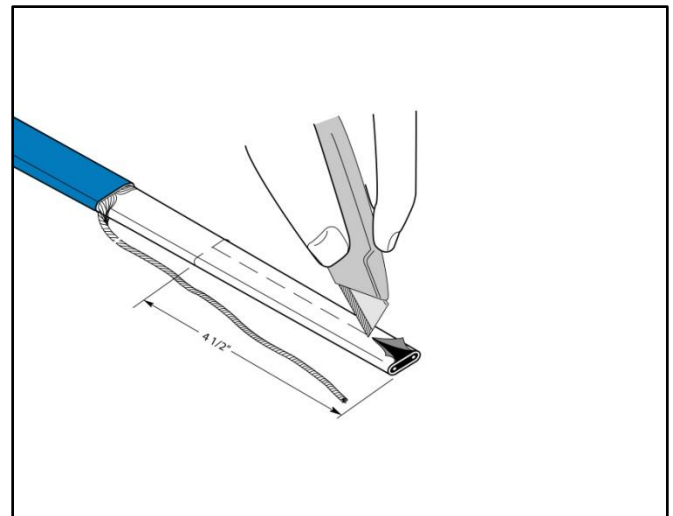

4 Twist and position the braid to one side of heating cable and then cut the insulating jacket back 4-1/2". Lightly score the inner insulating jacket and then bend the cable to break the jacket and peel it off.

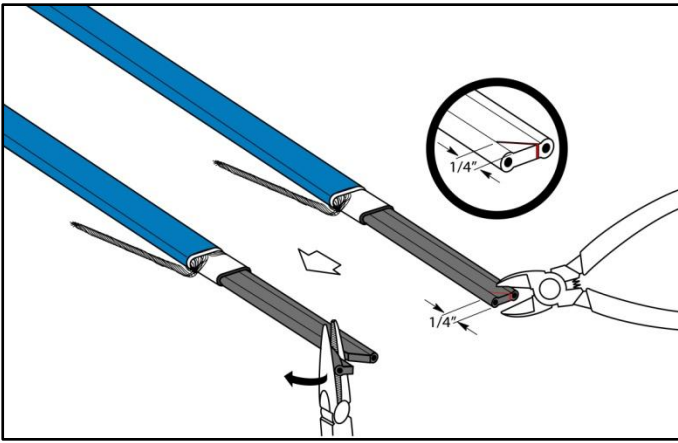

5 Notch the conductive core at the end and twist it back to peel the bus wires from the core.

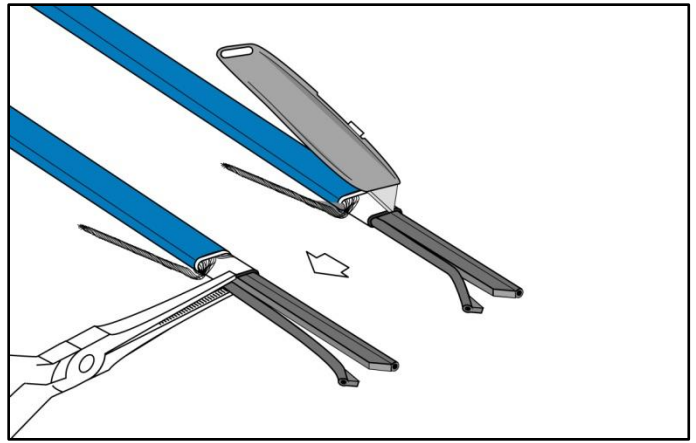

6 Score between the bus wires and bend the core to break it free and peel the core material away from the bus wires.

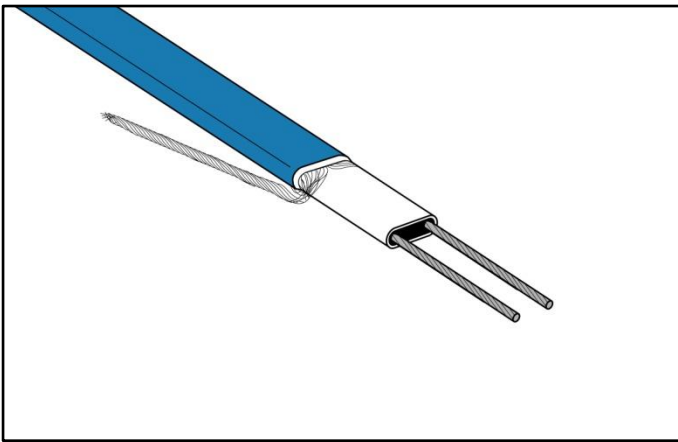

7 Cut and remove the remaining center core, leaving the bare conductors.

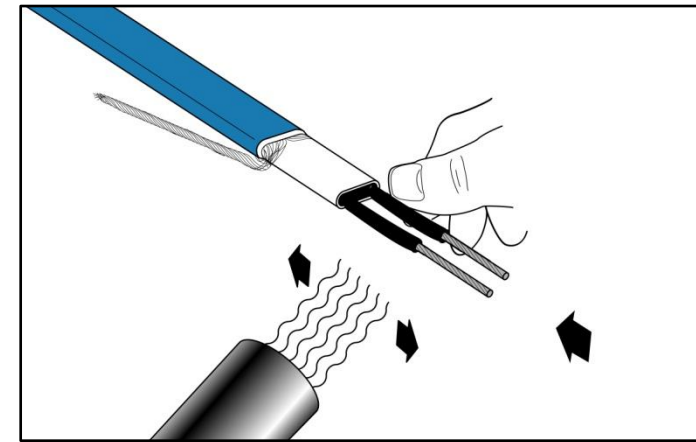

8 Slide the 1/8" dis. X 1" heat shrink tube over the bus wires. Apply heat to shrink the tubes, approximately 2 minutes at 600°F (315°C). Keep tubes up against the core while heat shrinking.

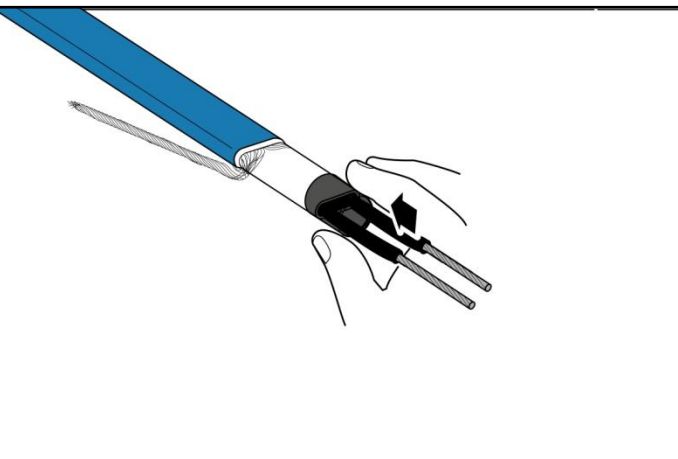

9 Center the 1/2" x 1" heat shrink tube over the cable core and bus wires as shown.

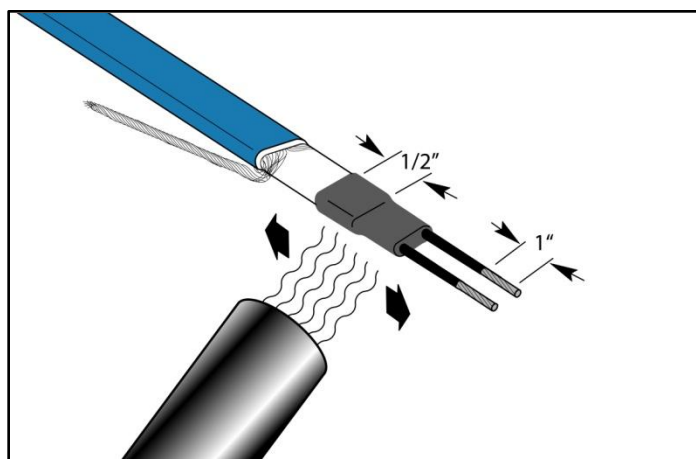

10 Heat evenly for approximately 3 minutes at 600°F (315°C) until it shrinks completely.

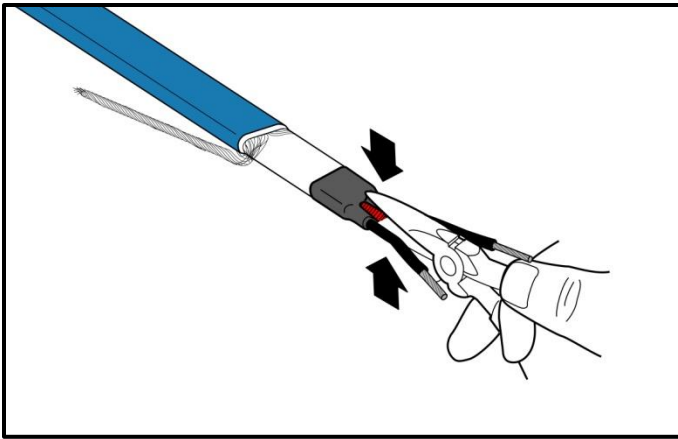

11 Immediately pinch the tube with pliers between the bus wires while it is still hot and hold for 10 seconds. Make sure the heat shrink tube is completely sealed between the bus wires with no visible gap.



12 Use the insulated connectors and crimp tool to connect black and white wires to bus wires of heating cable. Polarity does not matter.

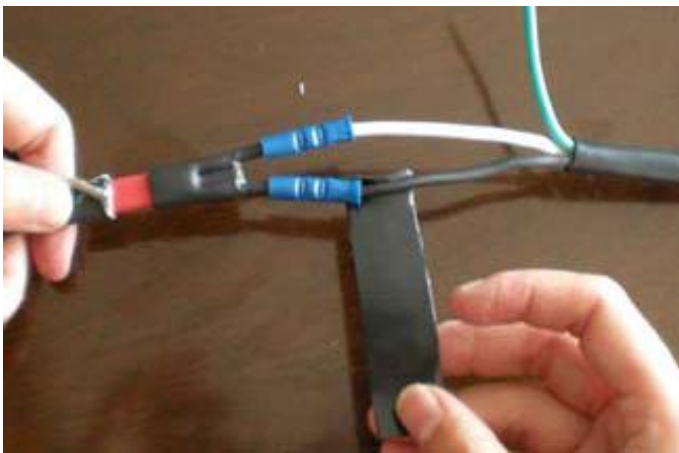

13 Remove the release paper from mastic strips, wrap one strip of mastic around the black wire at the end of the splice to make a water tight seal, then repeat this procedure for the white wire.



14 Squeeze the two mastic together to create a water tight seal.

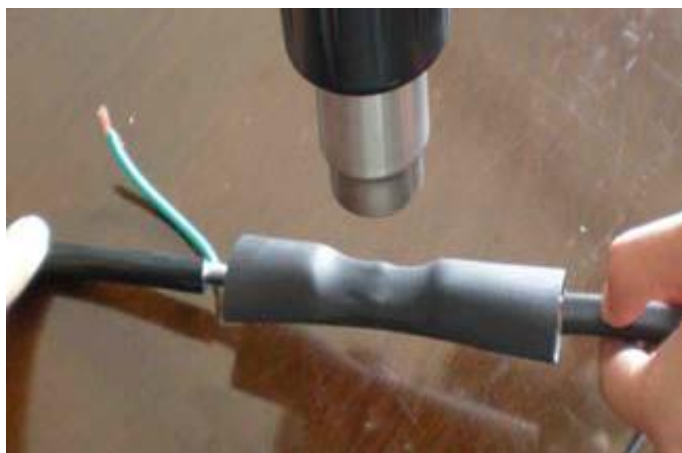

15 Center the 5" heat shrink tube over the splice, make sure it extends over the end of each heating cable and the cord. Start at the middle and work toward each end. Keep heating after tube has shrunk, to melt mastic and adhesive inside tube.

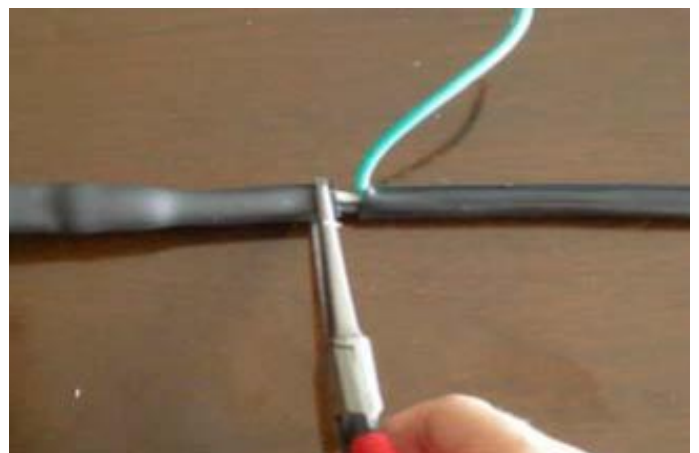

16 Make sure the adhesive appears at both ends. Immediately after shrinking, pinch one end of the tube and then the other end with needle nose pliers until the ends stay sealed. Hold for 10 seconds per end.



17 Use the un-insulated connector with a crimp tool to connect braid to green ground wire. Wrap the connector with the black cloth tape. Cover crimped connector completely.



18 Cover crimped connector completely.



19 Center the 8" heat shrink tube over the entire splice, make sure it extends over the end heating cable and the cord. Start at the middle and work toward each end.



20 Shrink the tubing completely.



Completed splice

Pipe freeze protection

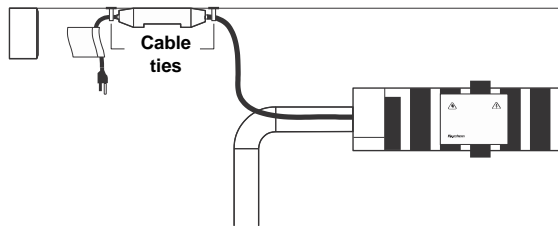

To prevent damage to the GFCI device and to provide strain relief to the cord, use cable ties to secure the device to the wall near the receptacle. Be careful not to damage either the cord or the ground-fault unit.

Note: Pipe must be fully insulated.

Pipe freeze protection

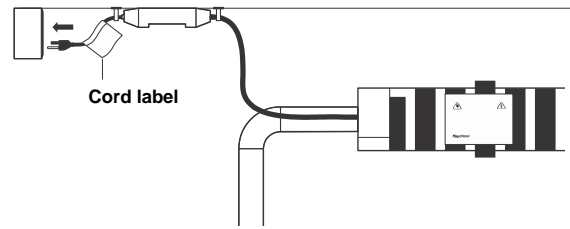

Plug the heating cable into a 15 amp, 120-Vac grounded outlet.

Make sure that:

- The cord label is visible.
- The indicator light on the ground-fault equipment protection device is on.
- The receptacle is properly weatherproofed (if outdoors).
- The ground-fault equipment protection device and the power connection splice will not be submerged.

Roof and gutter de-icing

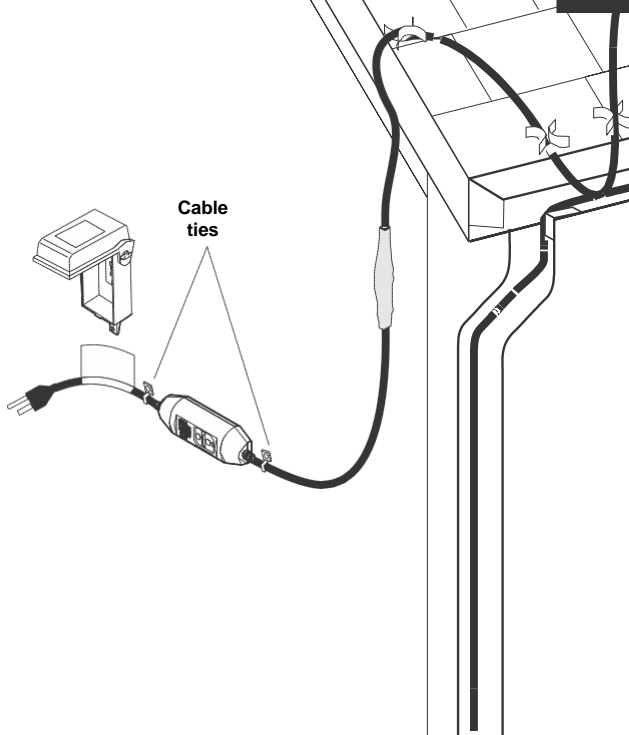

To prevent damage to the ground-fault equipment protection device and to provide strain relief, use clamp ties to secure the device to the wall near the receptacle. Be careful not to damage either the cord or the ground-fault unit.

The SRK08 should be mounted high up, away from persons to prevent damage to the unit and the risk of shock

Roof and gutter de-icing

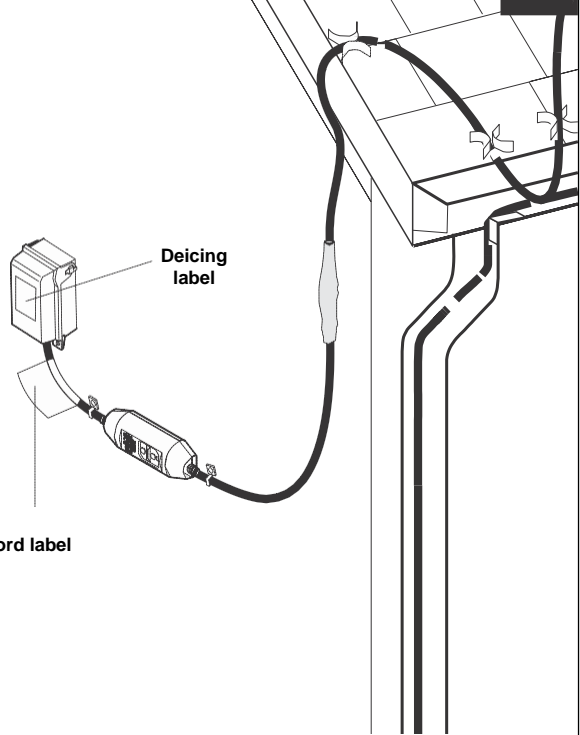

Plug the heating cable into a 15 amp, 120-Vac grounded outlet approved for wet locations.

Make sure that:

- The cord label is visible.
- The indicator light on the ground-fault equipment protection device is on.
- The receptacle is properly weatherproofed.
- The ground-fault equipment protection device and power connection splice will not be submerged.

Installation, Operation and Maintenance Instructions

IMPORTANT: Save These Instructions!

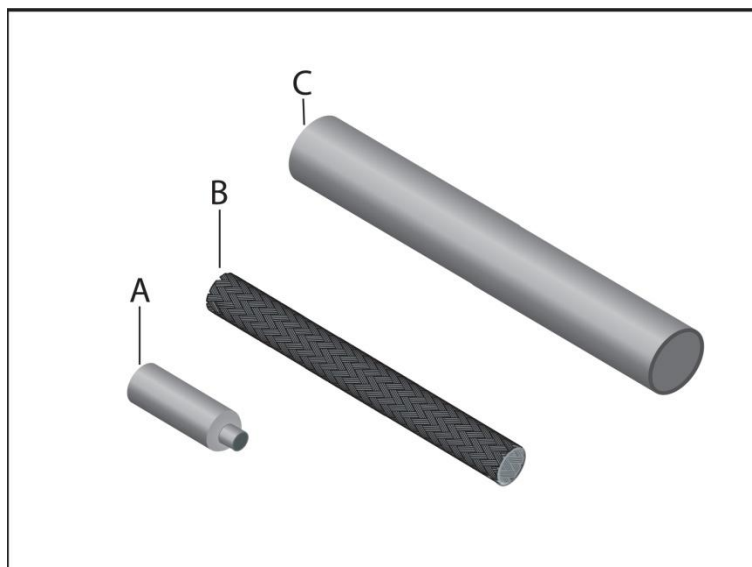

DESCRIPTION:

SR self-regulating heating cables are designed for a variety of pipe freeze protection as well as roof and gutter deicing applications. The heat output (wattage) increases and decreases based on the temperature, so the cable adjusts automatically to varying climate conditions. This unique feature ensures maximum energy efficiency by increasing the heat output only when it is needed. No thermostat is required.

⚠ WARNING: ELECTRIC SHOCK HAZARD
 Disconnect all power before installing or servicing the heating cable and accessories. SR heating cable must be grounded properly in accordance with the National Electrical Code (NEC). Failure to comply can result in personal injury or property damage. Only a qualified licensed electrical contractor shall install and service of SR heating cable and accessories, otherwise the warranty is voided.

Item	Qty	Description
A	1	Black heat shrink tube (3/4" dia. x 5" length)
B	1	Woven braid sleeve (1/2" dia. x 4" length)
C	1	Black heat shrink cap (1/2" dia. x 1-1/4" length)

Note:-All electrical wiring, including Ground Fault Circuit Interrupters (GFCI), must be done according to the NEC and local codes by a qualified installer. Article 426 of ANSI/NFPA 70 of National Electrical Code (NEC section 62 of CAN/CSA-C22.1, Canadian Electrical Code, Part I(CEC) governs the installation of this heat systems

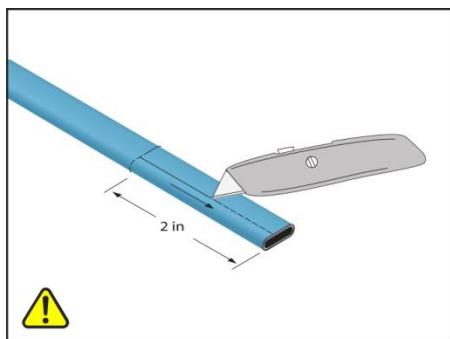

1 Score the outer jacket 2" from the end of the cable.

CAUTION: When removing the outer jacket, be careful not to damage the braid or the inner core insulation.

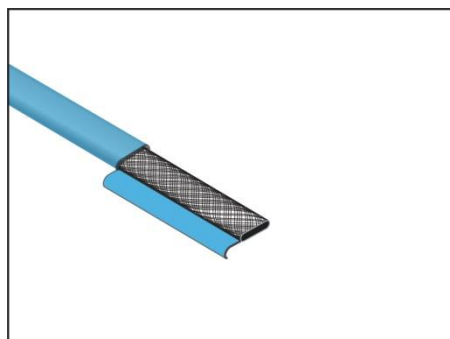

2 Remove the outer jacket to expose the braid.

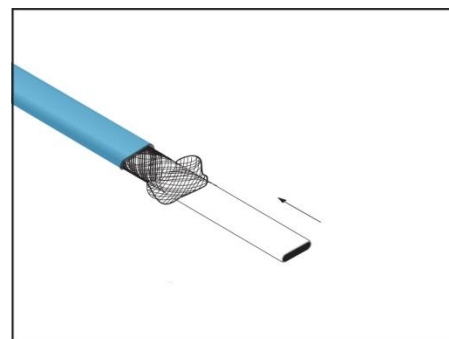

3 Push the braid back off the end of the cable.

WARNING: ELECTRIC SHOCK HAZARD
 Do not connect the bus wires together. Keep braid out of heat shrink cap.



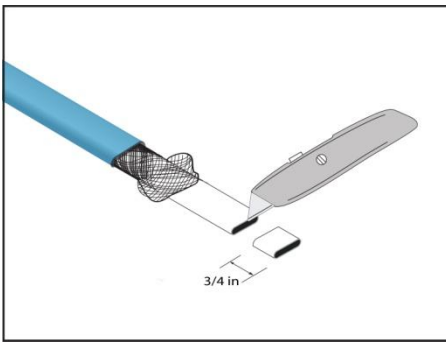

4 Push back the braid and cut 3/4" off the end of the cable..

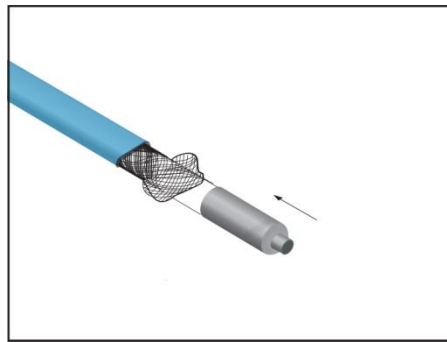

5 Push back the braid and slide the heat shrink cap over the end of the cable..

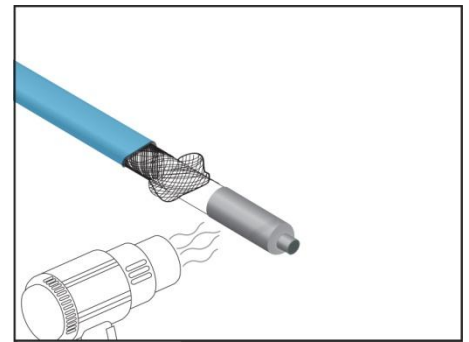

6 Apply heat evenly until the cap shrinks around the cable.

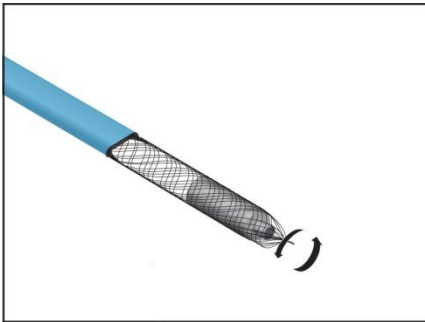

7 Pull the braid back over the end cap and twist the braid end together.

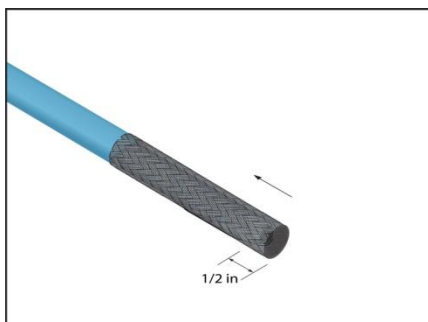

8 Slide the 4" woven braid sleeve over the cable, allowing 1/2" to extend past the end.

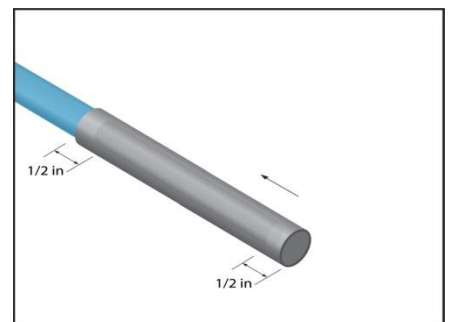

9 Slide the 5" heat shrink tube over the woven braid, allowing it to extend 1/2" past the end of the woven sleeve just applied.

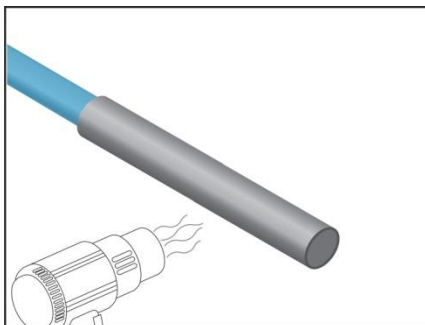

10 Apply heat evenly to the heat shrink tube until it shrinks around the cable

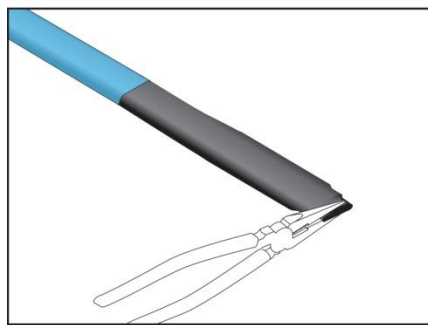

11 While the shrink tubing is still hot, gently squeeze the end with pliers and hold it until it has cooled.

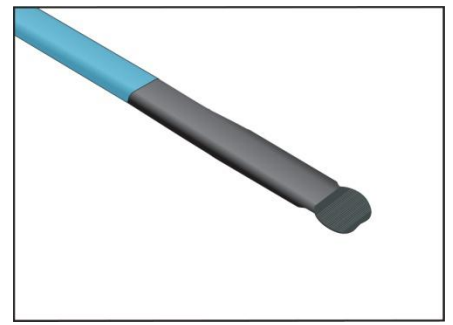

12 The end must remain sealed after the pliers are removed. If the tube does not remain sealed, then repeat steps 7 and 8.

Warranty Information:

King Electrical Mfg. Company will repair or replace, without charge to the original owner, any heating cable found to be defective or malfunctioning within the 2 year warranty. **In Case of Product Failure:** Contact King Electrical Mfg. Co. at 800.603.5464. The owner will be required to provide, within the designated warranty period, the following information: model number, date of purchase, and a complete description of the problem encountered with product. Upon receipt of the aforementioned, the company will reply to the owner within a period not to exceed fifteen (15) working days, and will provide the action to be taken by owner. **Terms:** This warranty requires the owner or his agent install the equipment in accordance with the National Electrical Code, any other applicable heating or electrical codes and the manufacturer's installation instructions. It further requires that reasonable and necessary maintenance be performed on the unit. Failure of proper maintenance by owner will void the warranty in its entirety. The company is not liable for any actions it deems to be abuse or misuse of the product. The customer shall be responsible for all costs incurred in the removal or reinstallation of products, including, but not limited to, labor costs, and shipping costs incurred to return products to King Manufacturing. At their discretion, King Manufacturing will decide to either repair or replace the product, with no charge to the owner, with return freight paid by King. The Company shall not be liable for consequential damages arising with respect to the product, whether based upon negligence, tort, strict liability or contract. No other written or oral warranty applies, nor any warranties by Representatives, Dealers, Employees of King or any other person. King Manufacturing can be contacted by phone at 206.762.0400, fax 206.763.7738 or website www.king-electric.com. The company's minimum liability shall not in any case exceed the list price for the product claimed to be defective.