

Electronic Unit Heater KB PlatinumX BMS Series

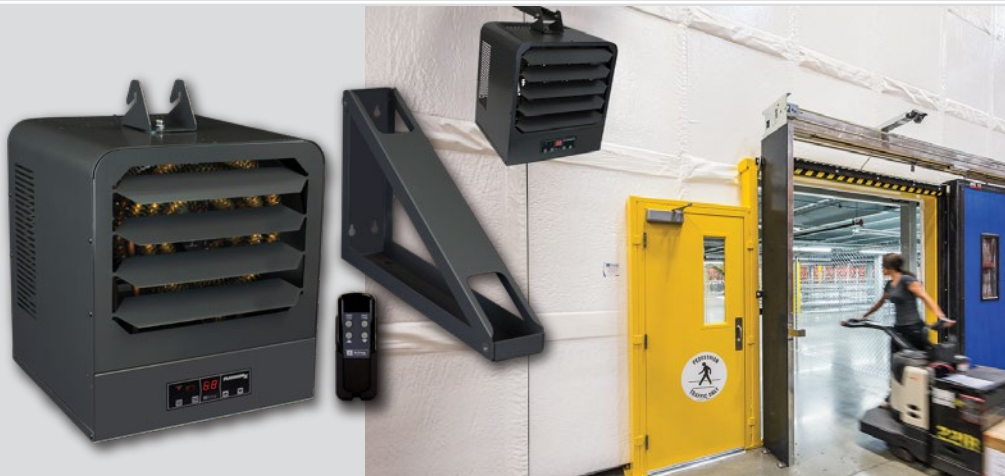

Model Code:

KB 20 12 -1 -PLTMX -BMS
A B C D E F

A: Series
B: 20 - 208V, 24 - 240/208V
27 - 277V, 48 - 480V
C: Watts (950 to 5700)
D: -1 = Single Phase
-3 = Three Phase
-3MP = 1-3 Phase
F: -PLTMX = 1-Stage Electronic Control
+ 24V Remote Stat Provision
G: Compatible with BMS Systems



- Energy-Saving PlatinumX electronic temperature controller
- Built-In provision for optional 24V remote thermostat
- Compatible with NEST / Any 24V WIFI stat
- Remote control included with wall holder
- Compatible with BMS systems
- Solid riveted construction for consistent, long-term durability
- Compatible with Optional ECO PRO Controller & Wireless Window/Door/Occupancy Sensors
- Auto Memory Feature: returns units to last settings after power outage
- Adjustable louvers to direct air
- Built-In fan delay to dissipate heat
- High mass steel fin heat exchanger
- Summer Fan Only & timer modes
- Patented Smart Limit Protection®
- Permanent lubricated unit bearing motor
- Universal wall/ceiling bracket included
- 5-Year limited warranty

The KB PlatinumX BMS Electronic Unit Heater w/ IR Remote Control

King's KB PlatinumX BMS series unit heaters are the most full-featured unit heaters on the market, with in-built electronic thermostat for accuracy and remote control for simple operation. Comes standard with a provision for adding an optional 24V thermostat, enabling remote temperature control with Nest and other WiFi thermostats, or seamless integration with a Building Management System (BMS). Includes integrated summer fan only and thermostat timer modes, the KB PlatinumX has you covered. Designed for use as primary or supplemental heat sources in large or exposed areas, including high-rise buildings, stores, warehouses, garages, water treatment and fire room vaults to prevent freezing. Spiral finned steel elements and high CFM ensure even air distribution producing cooler element operation, prolonging heater life. By combining the highest quality components, with a dynamically balanced fan blade, the KB PlatinumX unit heater will provide years of trouble-free service. Includes universal wall/ceiling bracket for simple installation.

Upgrade with the optional ECO PRO Controller, a remote wireless thermostat with a 7-day programmable schedule for personalized comfort or an optional wireless window/door and occupancy sensor to automatically reduce heat when windows are open or the room is unoccupied.

PlatinumX BMS Electronic Controller Features

- Electronic control for accuracy
- Thermostat timer mode (1-9 Hours)
- Summer Fan only mode
- Large LED display
- Built-In fan delay
- Built-In provision for optional 24V remote thermostat
- Remote control and wall/ceiling bracket included
- Compatible with NEST / any 24V WIFI Stat
- Compatible with Building Management Systems (BMS)
- Compatible with Optional ECO PRO Controller
- Compatible with Optional Window/Door or Occupancy Sensors

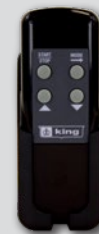

IR Remote

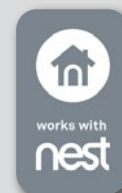

or Any 24V
WIFI Stat



Optional Controls



ECO Pro Controller



Occupancy Sensor



Window Sensor

Electronic Unit Heater KB PlatinumX BMS Series

Ordering Information - single phase

	MODEL	UPC	KW	BTUH (000)	PHASE	VOLTS	AMPS	MOTOR HP	CFM	TEMP. RISE	AIR THROW	MAX. MOUNT HEIGHT	*SIZE	WT. (lbs.)
208V	KB2003-1-PLTMX-BMS	70474	3.3	11.3	1	208	15.9	16W**	520	20°	15ft.	8ft.	A	30.5
	KB2004-1-PLTMX-BMS	70475	4	13.7	1	208	19.2	16W**	520	24°	15ft.	8ft.	A	30.5
	KB2005-1-PLTMX-BMS	70476	5	17.1	1	208	24.0	16W**	520	30°	15ft.	8ft.	A	30.5
	KB2007-1-PLTMX-BMS	70477	7.5	25.6	1	208	36.1	25W**	690	34°	20ft.	9ft.	B	45.0
	KB2010-1-PLTMX-BMS	70478	9.98	34.1	1	208	48.0	35W**	800	39°	24ft.	10ft.	B	45.0
	KB2012-1-PLTMX-BMS-FB	70479	12.5	42.7	1	208	60.1	50W**	935	42°	28ft.	11ft.	C	50.0
	KB2015-1-PLTMX-BMS-FB	70480	15	51.2	1	208	72.1	50W	1050	45°	33ft.	12ft.	C	50.0
240V	KB2403-1-PLTMX-BMS	70481	3.3	11.3	1	240/208*	13.8/11.9*	9W	520	20°	15ft.	8ft.	A	30.5
	KB2404-1-PLTMX-BMS	70482	4	13.5	1	240/208*	16.7/14.4*	9W	520	24°	15ft.	8ft.	A	30.5
	KB2405-1-PLTMX-BMS	70483	5	17	1	240/208*	20.8/18*	9W	520	30°	15ft.	8ft.	A	30.5
	KB2407-1-PLTMX-BMS	70484	7.5	25.6	1	240/208*	31.3/27*	16W	690	34°	20ft.	9ft.	B	45.0
	KB2410-1-PLTMX-BMS	70485	10	34.1	1	240/208*	41.7/36.1*	16W	800	40°	24ft.	10ft.	B	45.0
	KB2412-1-PLTMX-BMS-FB	70486	12.5	42.7	1	240/208*	52.1/45.1*	35W	935	42°	28ft.	11ft.	C	50.0
	KB2415-1-PLTMX-BMS-FB	70487	15	51.2	1	240/208*	62.5/54.1*	50W	1050	45°	33ft.	12ft.	C	50.0
277V	KB2703-1-PLTMX-BMS	70488	3	10.2	1	277	10.8	9W	520	18°	15ft.	8ft.	A	30.5
	KB2704-1-PLTMX-BMS	70489	4	13.5	1	277	14.4	9W	520	24°	15ft.	8ft.	A	30.5
	KB2705-1-PLTMX-BMS	70490	5	17	1	277	18.1	9W	520	30°	15ft.	8ft.	A	30.5
	KB2707-1-PLTMX-BMS	70491	7.5	25.6	1	277	27.1	16W	690	34°	20ft.	9ft.	B	45.0
	KB2710-1-PLTMX-BMS	70492	10	34.1	1	277	36.1	25W	800	40°	24ft.	10ft.	B	45.0

*Dual rated heaters will draw 13% less amps and 25% less wattage when operated at 208V. **240V motor derated for 208V operation.

Ordering Information - three phase

	MODEL	UPC	KW	BTUH (000)	PHASE	VOLTS	AMPS	MOTOR HP	CFM	TEMP. RISE	AIR THROW	MAX. MOUNT HEIGHT	*SIZE	WT. (lbs.)
208V	KB2012-3-PLTMX-BMS	70493	12.5	42.7	3	208	34.7	50W**	935	42°	31ft.	12ft.	C	50.0
	KB2015-3-PLTMX-BMS	70494	15	51.2	3	208	41.6	50W	1050	45°	33ft.	13ft.	C	50.0
	KB2020-3-PLTMX-BMS-FB	70495	20	68.3	3	208	55.5	1/4 HP	1750	36°	37ft.	14ft.	E	60.0
	KB2025-3-PLTMX-BMS-FB	70496	25	85.3	3	208	69.4	(2) 50W**	1870	42°	39ft.	15ft.	F	85.0
	KB2030-3-PLTMX-BMS-FB	70497	30	102.4	3	208	83.2	(2) 50W	2100	45°	41ft.	17ft.	F	85.0
	KB2412-3-PLTMX-BMS	70498	12.5	42.7	3	240/208*	30.1/26*	35W	935	42°	31ft.	12ft.	C	50.0
	KB2415-3-PLTMX-BMS	70499	15	51.2	3	240/208*	36.1/31.2*	50W	1050	45°	33ft.	13ft.	C	50.0
240V	KB2420-3-PLTMX-BMS-FB	70500	20	68.3	3	240/208*	48.1/41.6*	1/4 HP	1750	36°	37ft.	14ft.	E	60.0
	KB2425-3-PLTMX-BMS-FB	705501	25	85.3	3	240/208*	60.1/52.0*	(2) 35W	1870	42°	39ft.	15ft.	F	85.0
	KB2430-3-PLTMX-BMS-FB	70552	30	102.4	3	240/208*	72.1/62.4*	(2) 50W	2100	45°	41ft.	17ft.	F	85.0
	KB2440-3-PLTMX-BMS-FB	70503	40	136.5	3	240/208*	96.2/83.2*	(2) 1/4 HP	3500	36°	43ft.	19ft.	F	100.0
480V	KB4820-3-PLTMX-BMS	70504	20	68.3	3	480	24.0	1/4 HP	1750	36°	37ft.	14ft.	E	60.0
	KB4825-3-PLTMX-BMS	70505	25	85.3	3	480	30.1	(2) 35W	1870	42°	39ft.	15ft.	F	85.0
	KB4830-3-PLTMX-BMS	70506	30	102.4	3	480	36.1	(2) 50W	2100	45°	41ft.	17ft.	F	85.0
	KB4840-3-PLTMX-BMS-FB	70507	40	136.5	3	480	48.1	(2) 1/4 HP	3500	36°	43ft.	19ft.	G	100.0

*Dual rated heaters will draw 13% less amps and 25% less wattage when operated at 208V. **240V motor derated for 208V operation.

Ordering Information - multi-phase

	MODEL	UPC	KW	BTUH (000)	PHASE	VOLTS	AMPS	MOTOR HP	CFM	TEMP. RISE	AIR THROW	MAX. MOUNT HEIGHT	*SIZE	WT. (lbs.)
208V	KB2003-3MP-PLTMX-BMS	33203	3	10.2	1-3***	208	14.4/8.3	16W**	520	18°	20ft.	8ft.	C	45.0
	KB2005-3MP-PLTMX-BMS	33205	5	17.1	1-3***	208	24 & 13.9	16W**	520	30°	20ft.	8ft.	C	45.0
	KB2007-3MP-PLTMX-BMS	33207	7.5	25.6	1-3***	208	36.1 & 20.8	25W**	690	34°	24ft.	9ft.	C	46.5
	KB2010-3MP-PLTMX-BMS	33210	9.98	34.1	1-3***	208	48/27.7	35W**	800	39°	29ft.	11ft.	C	46.5

Continued on next page

Electronic Unit Heater KB PlatinumX BMS Series

Ordering Information - multi-phase

	MODEL	UPC	KW	BTUH (000)	PHASE	VOLTS	AMPS	MOTOR HP	CFM	TEMP. RISE	AIR THROW	MAX. MOUNT HEIGHT	*SIZE	WT. (lbs.)
240V	KB2403-3MP-PLTMX-BMS	33204	3	10.2	1-3***	240/208*	12.5/7.2* & 10.8/6.2*	9W	520	18°	20ft.	8ft.	C	45.0
	KB2405-3MP-PLTMX-BMS	33206	5	17.1	1-3***	240/208*	20.8/12* & 18/10.4*	9W	520	30°	20ft.	8ft.	C	45.0
	KB2407-3MP-PLTMX-BMS	33208	7.5	25.6	1-3***	240/208*	31.2/18* & 27/15.6*	16W	690	34°	24ft.	9ft.	C	46.5
	KB2410-3MP-PLTMX-BMS	33209	10	34.1	1-3***	240/208*	41.7/24* & 36.1/20.8*	25W	800	40°	29ft.	11ft.	C	46.5
480V	KB4803-3MP-PLTMX-BMS	33215	3	10.2	1-3***	480	6.3/3.6	9W	520	18°	20ft.	8ft.	C	45.0
	KB4805-3MP-PLTMX-BMS	33216	5	17.1	1-3***	480	10.4 & 6.0	9W	520	30°	20ft.	8ft.	C	45.0
	KB4807-3MP-PLTMX-BMS	33217	7.5	25.6	1-3***	480	15.6/9.0	16W	690	34°	24ft.	9ft.	C	46.5
	KB4810-3MP-PLTMX-BMS	33218	10	34.1	1-3***	480	20.8 & 12	25W	800	40°	29ft.	11ft.	C	46.5
	KB4812-3MP-PLTMX-BMS	33219	12.5	42.7	1-3***	480	26 & 15	35W	935	42°	31ft.	12ft.	C	50.0
	KB4815-3MP-PLTMX-BMS	33220	15	51.2	1-3***	480	31.3 & 18	50W	1050	45°	33ft.	13ft.	C	50.0

*Dual rated heaters will draw 13% less amps and 25% less wattage when operated at 208V. **240V motor derated for 208V operation.

***3MP Prefired for 3-Phase, Field Convertible to 1-Phase

Optional Field-Installed Control Accessories

MODEL	UPC	DESCRIPTION
ECO-PRO-CONTROLLER	70421	Pro Controller - 7-Day Programmable Thermostat/Remote Sensor/Remote
ECO-PRO-RF-PIR-SENSOR	70422	RF Battery Powered PIR Occupancy Sensor for ECO Models
ECO-PRO-RF-WINDOW-SENSOR	70423	RF Battery Powered PIR Window or Door Sensor for ECO Models

Optional Field Installed Disconnect Switch

ADD SUFFIX:	UPC	DESCRIPTION	WT. (lbs.)
DS32	13480	Disconnect Switch, Field Installed Kit, 32 AMP, 600V	2.0
DS63	13481	Disconnect Switch, Field Installed Kit, 63 AMP, 600V	2.0
DS80	13482	Disconnect Switch, Field Installed Kit, 80 AMP, 600V	2.0
DS100	13483	Disconnect Switch, Field Installed Kit, 100 AMP, 600V	5.0

Replacement Accessories

MODEL	UPC	DESCRIPTION	WT. (lbs.)
KBB-1	13484	Replacement Universal Wall/Ceiling Small Mounting Bracket (for heaters with size A heaters)	1.9
KBB-2	13485	Replacement Universal Wall/Ceiling Large Mounting Bracket (for heaters with size B and C)	2.6
KBB-3	13488	Replacement Universal Wall/Ceiling Large Mounting Bracket (for heaters with size F & G)	3.9
KBHS	13486	Replacement Hook Swivel	0.4
KBHK	13487	Replacement Hardware Kit	0.1

Bracket Selection Chart

BRACKET #	HEATER KW SIZE USED WITH	BRACKET DIMENSIONS											
		L	W	H	A	B	C	D	E	F	X	Y	Z
KBB-1	3 to 5 kW (1 phase)	12½"	2 ₁₅ / ₁₆ "	10 ₁ / ₁₆ "	1 ₃ / ₁₆ "	7"	1 ₇ / ₈ "	1 ₇ / ₈ "	9¼"	1 ₇ / ₈ "	¾"	1"	½"
KBB-2	7.5 to 10 kW (1 phase) 3 to 20 kW (3 phase)	16 ₇ / ₈ "	2 ₁₅ / ₁₆ "	10 ₁ / ₈ "	1¼"	7"	1 ₇ / ₈ "	1 ₅ / ₈ "	13 ₅ / ₈ "	1 ₅ / ₈ "	¾"	1"	1½"
KBB-3	25 to 40 kW (3 phase)	19½"	4 ₃ / ₁₆ "	13 ₃ / ₁₆ "	1 ₅ / ₁₆ "	10"	1 ₇ / ₈ "	1 ₅ / ₈ "	16¼"	1 ₁ / ₈ "	11 ₁ / ₁₆ "	1"	2"

Electronic Unit Heater KB PlatinumX BMS Series

Expand Your Control w/ Optional ECO PRO Controller & Wireless Sensors

For 7-Day Programmable Heating Schedule & Automatic Temperature Setbacks



Optional ECO Pro Controller
Programmable 7-Day Heating Schedule & Remote Temperature Sensor

RF Occupancy Sensor
(optional)

or

RF Window/Door Sensor
(optional)

Room Unoccupied
Setback Options: 45°F, 55°F, 60°F or 65°

Open Window or Door
Setback Options: 40°F, 45°F, 50°F or 55°

Upgrade to the ECO PRO CONTROLLER: 7-Day Programmable Thermostat with Remote Temperature Sensing



Eco Pro Controller

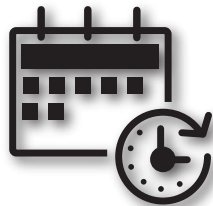

7-Day Programmable Heating Schedule



Balanced Heat Throughout the Space



Comfort, Right Where You Want It



Remote Temperature Sensing

Electronic Unit Heater KB PlatinumX BMS Series

Dimensional Data

Double Unit Size F & G

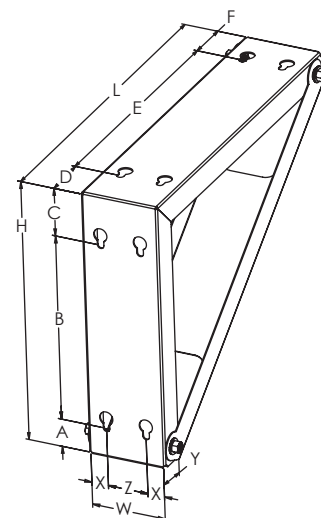
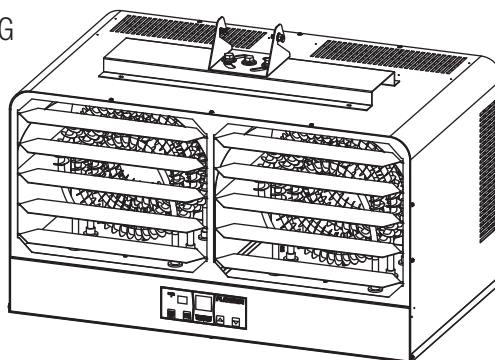
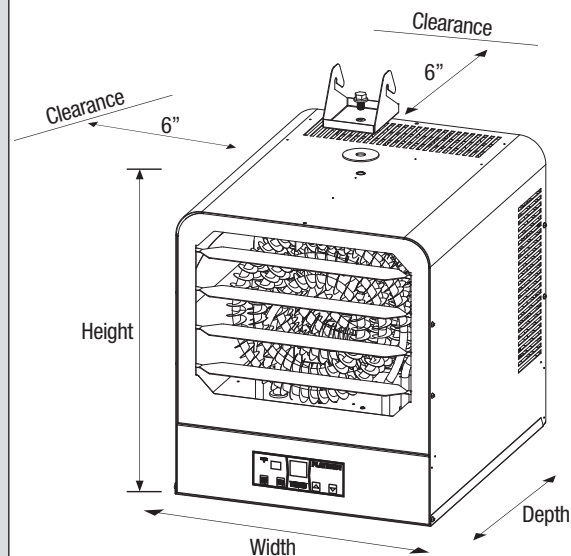

HEATER SIZE	HEIGHT	DEPTH	WIDTH
A	16.5"	11"	15"
B	16.5"	13.5"	15"
C	16.5"	18"	15"
E	20.5"	23.8"	15"
F	16.5"	18"	30"
G	20.5"	23.8"	30"

KBB-1, KBB-2 & KBB-3

Unit heater brackets can be used for mounting on ceiling or wall. 3/8" threaded hole on top of unit heater can also be used with threaded rod to drop the unit closer to the floor. Refer to bracket selection chart.

Engineering Specifications

Contractor shall supply and install KB PlatinumX BMS Series unit heaters manufactured by King Electrical Mfg. Company. Heaters shall be of the wattage and voltage as indicated on the plans.

Construction: All exterior and interior metal enclosure parts are made from 20 gauge electrogalvanized Steel with a rust inhibiting baked enamel finish. Smooth rounded corners and protective edge trim give an attractive modern appearance.

PlatinumX Electronic Thermostat Control: Thermostat Temperature Range: 40° to 95°. Up, down temperature mode. Start/Stop. Standard on all heaters. Heaters 25kW and above are ECO2S+ 2-stage heaters.

Auto Memory Feature: Returns Unit To Last Settings After Power Outage.

Adjustable Outlet Louver: Louvers direct air up or down as needed for the heating application.

Rear Intake Screen: Heavy gauge steel screen protects against foreign objects making accidental contact with the rotating fan blade.

Spiral Fin Elements: The metal sheath element is copper brazed with spiral fins then molded into a coil configuration. This combination produces the best heat transfer while eliminating the potential for hot spots by positioning the element in the maximum airflow stream.

Totally Enclosed Fan Motor: Permanently lubricated long life, unit bearing with 20cc of oil. Epoxy-coated motor with enclosed rotor resists moisture and corrosion for long-lasting, trouble-free operation.

Aluminum Fan Blade: Axial flow-type fan mounted directly to the motor shaft for maximum efficiency.

Thermal Overload: Heaters shall be equipped with King's patented thermal overload Smart Limit Protection®, which disconnects elements and motor in the event normal operating temperatures are exceeded. If thermal overload trips due to abnormal operating temperatures, thermal overload shall remain open until manually reset by turning the heater off for 15 minutes. Automatically reset of thermal overloads, which allow the element to continue to cycle under abnormal conditions, will not be accepted.

Internal Controls: Magnetic contactors are standard on all 480V heaters, all 208V/1-Phase, 240V/1-Phase, 277V/1-Phase heaters above 6kW, and all 3-Phase heaters.

Provision For 24V Remote Thermostat: Includes terminals to connect an optional 24V Thermostat or BMS Systems. Compatible with NEST / any 24V WIFI Stat / 5-Wire BMS Systems.

Fusing: Internal circuit fusing is provided when the heater ampacity exceeds 48 Amps to comply with N.E.C. standards. A fan delay is provided standard on models 12.5-kW and above to dissipate residual heat from the heating elements. **Easy Installation:** A quick access panel located on the bottom of the heater allows for quick wiring and easy maintenance for the life of the heater. Includes universal wall/ceiling bracket for simple installation.

Approvals: cULus (E41422)