

INSTALLATION AND MAINTENANCE

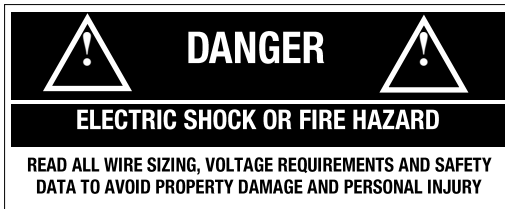

KF/KFS ECO2S Series Electric Furnace



**UNIVERSAL
INSTRUCTIONS**



Figure 1



**“WARNING: RISK OF ELECTRIC SHOCK. CAN CAUSE INJURY OR DEATH.
DISCONNECT ALL REMOTE ELECTRIC POWER SUPPLIES BEFORE SERVICING.”**

CAUTION: Turn off the power source supplying the heater before attempting installation, maintenance or repairs. Lock or tag circuit breaker or fuse panel door. Failure to do so could result in serious electrical shock, burns, or possible death.

It is *extremely important* you verify the electrical power supply is the same voltage as the heater being installed. 208V, 240 and 480 Volt heaters are *not* interchangeable. Powering a 480 Volt unit with 240 Volt supply wires will reduce the heater output by approximately 75% and is never recommended. Powering a 208V or 240 Volt unit with 480 Volt supply wires will destroy the heater and voids all warranties.

KING furnaces can be installed with a minimum of 1 inch clearance for compact, space saving installations in either vertical upflow, downflow or horizontal position. When installed in the downflow position, the Combustible Floor SubBase Accessory must be used.

CHECK: Ensure blower wheel is free-turning and that element assemblies are in place. Be sure that the filter is in proper position and not torn or damaged. Check that the blower housing and motor have not separated from the element compartment during shipment and inspect the terminals & wiring to ensure nothing came loosing during shipping.

NOTE: The attached UL label pertains to the furnace only. It does not cover any air cooler, condensing unit or air cleaner, which may be used with the furnace. The optional QOU cabinets are designed for slip-in addition of an evaporator coil at a later date. Approval of the complete system of air conditioning requires compliance with local codes.

GENERAL REQUIREMENTS AND SPECIFICATIONS

- 1. LOCATION** – The furnace should be centrally located to the heating area.
- 2. POSITIONS** – The furnace can be installed for vertical or horizontal operation. When installed horizontally, the furnace should be positioned with the door on the top or bottom to ensure the motor bearings are properly oriented. In vertical downflow installations, use only an “L” or “T” shaped supply plenum connection with no openings or registers directly below furnace or within 3 feet of the outlet opening.
- 3. INSTALLATION CLEARANCES** – As shipped from the factory, each unit is approved for “zero inch” clearance. If additional clearance is required, it will be indicated on the data label attached to the furnace.
- 4. TEMPERATURE RISE** – Furnaces are shipped to operate at 0.20” (5 mm) W.C. (50 Pa) external static pressure. They are certified for operation up to 0.80” static. Check the following page for temperature rise table on specification chart and, if necessary, adjust the unit speed to match.
- 5. SERVICE CLEARANCE** – Units are serviced from the FRONT door. Leave at least 24” (610 mm) clearance in front of the door for service access.

INSTALLATION DIAGRAMS

Typical Installation

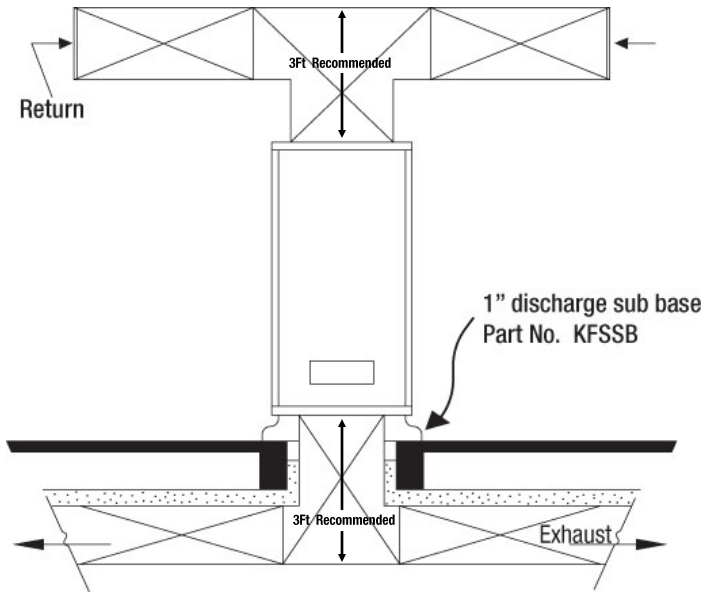

Installation Options:

DOWN FLOW

UP FLOW

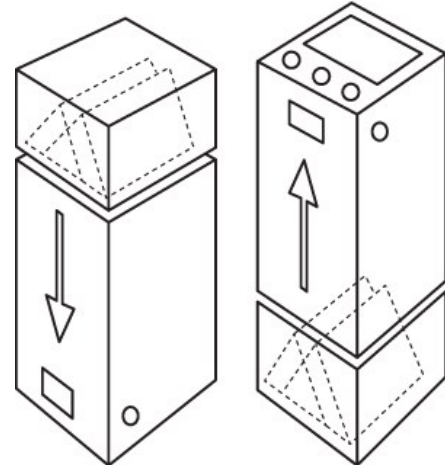

Typical Horizontal Installation

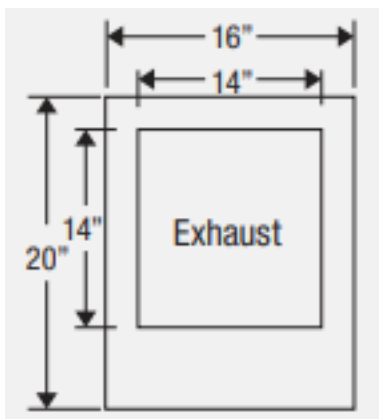
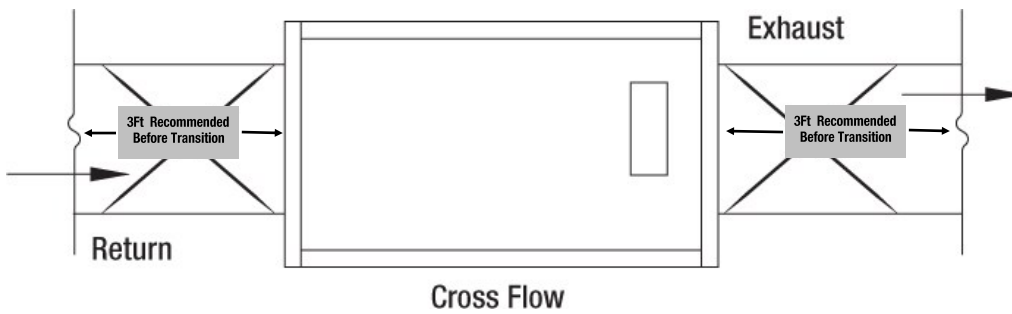

Mounting Clearances From Combustibles

DIMENSIONAL CLEARANCE	
CABINET SIDES	1 INCH
CABINET FRONT	0 INCH
EXHAUST DUCT WITHIN 3 FEET OF FURNACE	1 INCH
RETRUN AIR PLENUM	0 INCH

AIRFLOW CHART

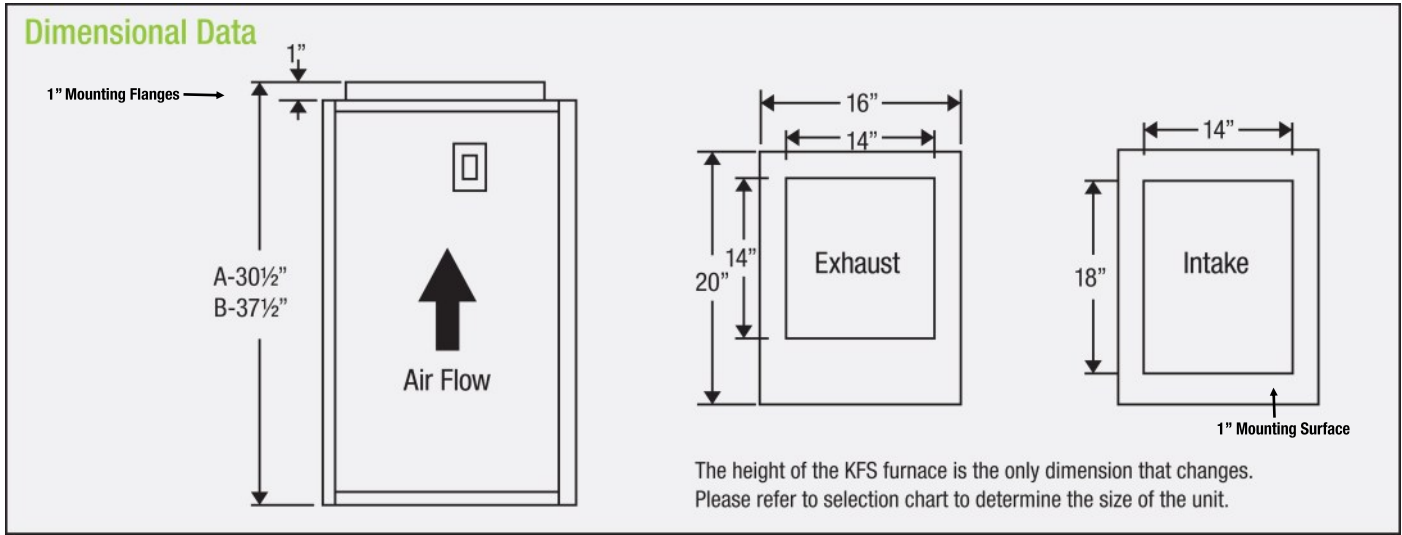

Air Flow Chart (For 4 to 17.25kW Units with 1/3HP ECM Motor)

MODEL	KW	TORQUE	0.1"WC		0.2"WC		0.3"WC		0.4"WC		0.5"WC		0.6"WC		0.7"WC		0.8"WC		0.9"WC		1.0"WC			
			CFM	RISE (F)	CFM	RISE (F)	CFM	RISE (F)	CFM	RISE (F)	CFM	RISE (F)	CFM	RISE (F)	CFM	RISE (F)	CFM	RISE (F)	CFM	RISE (F)	CFM	RISE (F)	CFM	RISE (F)
KF/KFS**04	4	(2) 6.8	832	15	708	18	593	21	510	25	442	29	374	34	320	39	278	46						
		9.4	1,030	12	919	14	826	15	739	17	658	19	594	21	546	23	494	26						
		12.0	1,168	11	1,085	12	992	13	902	14	835	15	783	16	736	17	700	18						
		17.0	1,376	9	1,320	10	1,259	10	1,189	11	1,116	11	1,060	12	1,016	12	987	13						
		20.0	1,582	8	1,536	8	1,462	9	1,380	9	1,275	10	1,192	11	1,107	11	1,043	12						
KF/KFS**05	5	(2) 6.8	832	19	708	22	593	27	510	31	442	36	374	42	320	49	278	57						
		9.4	1,030	15	919	17	826	19	739	21	658	24	594	27	546	29	494	32						
		12.0	1,168	14	1,085	15	992	16	902	18	835	19	783	20	736	21	700	23						
		17.0	1,376	11	1,320	12	1,259	13	1,189	13	1,116	14	1,060	15	1,016	16	987	16						
		20.0	1,582	10	1,536	10	1,462	11	1,380	11	1,275	12	1,192	13	1,107	14	1,043	15						
KF/KFS**08	8	(1) 6.8	832	30	708	36	593	43	510	50	442	57	374	68	320	79	278	91						
		(2) 9.4	1,030	25	919	27	826	31	739	34	658	38	594	43	546	46	494	51						
		12.0	1,168	22	1,085	23	992	25	902	28	835	30	783	32	736	34	700	36						
		17.0	1,376	18	1,320	19	1,259	20	1,189	21	1,116	23	1,060	24	1,016	25	987	26						
		20.0	1,582	16	1,536	16	1,462	17	1,380	18	1,275	20	1,192	21	1,107	23	1,043	24						
KF/KFS**10	10	(1) 6.8	832	38	708	45	593	53	510	62	442	71	374	84	320	99	278	NR						
		(2) 9.4	1,030	31	919	34	826	38	739	43	658	48	594	53	546	58	494	64						
		12.0	1,168	27	1,085	29	992	32	902	35	835	38	783	40	736	43	700	45						
		17.0	1,376	23	1,320	24	1,259	25	1,189	27	1,116	28	1,060	30	1,016	31	987	32						
		20.0	1,582	20	1,536	21	1,462	22	1,380	23	1,275	25	1,192	27	1,107	29	1,043	30						
KF/KFS**12	12	6.8	832	46	708	54	593	64	510	74	442	86	374	101	320	NR	278	NR						
		(1) 9.4	1,030	37	919	41	826	46	739	51	658	58	594	64	546	69	494	77						
		(2) 12.0	1,168	32	1,085	35	992	38	902	42	835	45	783	48	736	52	700	54						
		17.0	1,376	28	1,320	29	1,259	30	1,189	32	1,116	34	1,060	36	1,016	37	987	38						
		20.0	1,582	24	1,536	25	1,462	26	1,380	27	1,275	30	1,192	32	1,107	34	1,043	36						
KF/KFS**15	15	6.8	832	57	708	67	593	80	510	93	442	107	374	NR	320	NR	278	NR						
		(1) 9.4	1,030	46	919	52	826	57	739	64	658	72	594	80	546	87	494	96						
		(2) 12.0	1,168	41	1,085	44	992	48	902	53	835	57	783	61	736	64	700	68						
		17.0	1,376	34	1,320	36	1,259	38	1,189	40	1,116	42	1,060	45	1,016	47	987	48						
		20.0	1,582	30	1,536	31	1,462	32	1,380	34	1,275	37	1,192	40	1,107	43	1,043	45						
KF/KFS**18	17.25	6.8	832	66	708	77	593	92	510	107	442	NR	374	NR	320	NR	278	NR						
		(1) 9.4	1,030	53	919	59	826	66	739	74	658	83	594	92	546	100	494	110						
		12.0	1,168	47	1,085	50	992	55	902	60	835	65	783	70	736	74	700	78						
		(2) 17.0	1,376	40	1,320	41	1,259	43	1,189	46	1,116	49	1,060	51	1,016	54	987	55						
		20.0	1,582	34	1,536	35	1,462	37	1,380	40	1,275	43	1,192	46	1,107	49	1,043	52						

A ** Represents the voltage, 20=208V, 24=240V, 48=480V. Voltage of the KF/KFS unit does not affect the data in this table.
 B NR= Not Recommended, Temperature Rise is above maximum design parameter.
 C The highlighted cells are the factory default torque setting for each model. The ECM motor has 5 field adjustable torque settings, allowing for a wide range of design choices.
 D (1) = Stage 1 Torque Settings (2) = Stage 2 Torque Settings / (2) = Default for Single Stage KFUH
 E Blower: 10" diameter, 8" wide

AIRFLOW CHART

Air Flow Chart (For 20 to 25kW Units with 1/2HP ECM Motor)

MODEL	KW	0.1"WC		0.2"WC		0.3"WC		0.4"WC		0.5"WC		0.6"WC		0.7"WC		0.8"WC		0.9"WC		1.0"WC			
		TORQUE	CFM	RISE	CFM	RISE	CFM	RISE	CFM	RISE	CFM	RISE	CFM	RISE	CFM	RISE	CFM	RISE	CFM	RISE	CFM	RISE	
KF/KFS**20	20			(F)		(F)		(F)		(F)		(F)		(F)		(F)		(F)		(F)		(F)	
		(1) 15.0			1,258	50	1,262	50	1,193	53	1,132	56	1,054	60	910	69	834	76	821	77	705	90	
		(2) 19.0			1,466	43	1,419	45	1,300	49	1,285	49	1,218	52	1,180	54	1,015	62	979	65	934	68	
		22.5			1,575	40	1,570	40	1,564	40	1,363	46	1,347	47	1,284	49	1,256	50	1,200	53	1,152	55	
		26.0			1,690	37	1,679	38	1,640	39	1,546	41	1,472	43	1,430	44	1,378	46	1,358	47	1,315	48	
30.0			1,771	36	1,766	36	1,723	37	1,728	37	1,569	40	1,542	41	1,522	42	1,487	43	1,415	45			
KF/KFS**25	25	15.5			1,258	63	1,262	63	1,193	66	1,132	70	1,054	75	910	87	834	95	821	96	705	NR	
		19.0			1,466	54	1,419	56	1,300	61	1,285	61	1,218	65	1,180	67	1,015	78	979	81	934	85	
		(1) 22.5			1,575	50	1,570	50	1,564	51	1,363	58	1,347	59	1,284	62	1,256	63	1,200	66	1,152	69	
		(2) 26.0			1,690	47	1,679	47	1,640	48	1,546	51	1,472	54	1,430	55	1,378	57	1,358	58	1,315	60	
		30.0			1,771	45	1,766	45	1,723	46	1,728	46	1,569	50	1,542	51	1,522	52	1,487	53	1,415	56	

A ** Represents the voltage, 20=208V, 24=240V, 48=480V. Voltage of the KF/KFS unit does not affect the data in this table.
 B NR= Not Recommended, Temperature Rise is above maximum design parameter.
 C The highlighted cells are the factory default torque setting for each model. The ECM motor has 5 field adjustable torque settings, allowing for a wide range of design choices.
 D (1) = Stage 1 Torque Settings (2) = Stage 2 Torque Settings / (2) = Default for Single Stage KFUH
 E Blower: 10" diameter, 8" wide

Air Flow Chart (For 20 to 25kW Units with OPTIONAL 3/4HP ECM Motor)

MODEL	KW	0.1"WC		0.2"WC		0.3"WC		0.4"WC		0.5"WC		0.6"WC		0.7"WC		0.8"WC		0.9"WC		1.0"WC			
		TORQUE	CFM	RISE	CFM	RISE	CFM	RISE	CFM	RISE	CFM	RISE	CFM	RISE	CFM	RISE	CFM	RISE	CFM	RISE	CFM	RISE	
KF/KFS**20	20			(F)		(F)		(F)		(F)		(F)		(F)		(F)		(F)		(F)		(F)	
		(1) 26.0			1,592	40	1,592	40	1,581	40	1,551	41	1,529	41	1,496	42	1,432	44	1,353	47	1,231	51	
		30.0			1,789	35	1,758	36	1,716	37	1,650	38	1,598	40	1,552	41	1,451	41	1,451	44	1,282	49	
		(2) 35.0			1,814	35	1,819	35	1,828	35	1,866	34	1,849	34	1,794	35	1,688	37	1,561	40	1,316	48	
		40.5			2,080	30	2,122	30	2,082	30	2,054	31	1,916	33	1,814	35	1,700	37	1,482	43	1,230	51	
45.0			2,174	29	2,154	29	2,148	29	2,138	30	2,094	30	1,928	33	1,671	38	1,471	43	1,232	51			
KF/KFS**25	25	(1) 26.0			1,592	50	1,592	50	1,581	50	1,551	51	1,529	52	1,496	53	1,432	55	1,353	58	1,231	NR	
		30.0			1,789	44	1,758	45	1,716	46	1,692	47	1,650	48	1,598	49	1,552	51	1,451	54	1,282	62	
		(2) 35.0			1,814	44	1,819	43	1,828	43	1,866	42	1,849	43	1,794	44	1,688	47	1,561	51	1,316	60	
		40.5			2,080	38	2,122	37	2,082	38	2,054	38	1,916	41	1,814	44	1,700	46	1,482	53	1,230	64	
		45.0			2,174	36	2,154	37	2,139	37	2,138	37	2,094	38	1,928	41	1,671	47	1,471	54	1,232	64	

A ** Represents the voltage, 20=208V, 24=240V, 48=480V. Voltage of the KF/KFS unit does not affect the data in this table.
 B NR= Not Recommended, Temperature Rise is above maximum design parameter.
 C The highlighted cells are the factory default torque setting for each model. The ECM motor has 5 field adjustable torque settings, allowing for a wide range of design choices.
 D (1) = Stage 1 Torque Settings (2) = Stage 2 Torque Settings / (2) = Default for Single Stage KFUH
 E Blower: 10" diameter, 8" wide

Air Flow Chart (For 30 to 35kW Units with 3/4HP ECM Motor)

MODEL	KW	0.1"WC		0.2"WC		0.3"WC		0.4"WC		0.5"WC		0.6"WC		0.7"WC		0.8"WC		0.9"WC		1.0"WC			
		TORQUE	CFM	RISE	CFM	RISE	CFM	RISE	CFM	RISE	CFM	RISE	CFM	RISE	CFM	RISE	CFM	RISE	CFM	RISE	CFM	RISE	
KF/KFS**30	30			(F)		(F)		(F)		(F)		(F)		(F)		(F)		(F)		(F)		(F)	
		(1) 26.0			1,592	60	1,592	60	1,581	60	1,551	61	1,529	62	1,496	63	1,432	NR	1,353	NR	1,231	NR	
		30.0			1,789	53	1,758	54	1,716	55	1,692	56	1,650	57	1,598	59	1,552	61	1,451	65	1,282	74	
		35.0			1,814	52	1,819	52	1,828	52	1,866	51	1,849	51	1,794	53	1,688	56	1,561	61	1,316	72	
		(2) 40.5			2,080	46	2,122	45	2,082	46	2,054	46	1,916	49	1,814	52	1,700	56	1,482	64	1,230	77	
45.0			2,174	44	2,154	44	2,148	44	2,138	44	2,094	45	1,928	49	1,671	57	1,471	64	1,232	77			
KF/KFS**35	35	26.0			1,592	69	1,592	69	1,581	60	1,551	71	1,529	72	1,496	NR	1,432	NR	1,353	NR	1,231	NR	
		(1) 30.0			1,789	62	1,758	63	1,716	64	1,692	65	1,650	67	1,598	69	1,552	71	1,451	NR	1,282	NR	
		35.0			1,814	61	1,819	61	1,828	60	1,866	59	1,849	60	1,794	62	1,688	66	1,561	71	1,316	84	
		40.5			2,080	53	2,122	52	2,082	53	2,054	54	1,916	58	1,814	61	1,700	65	1,482	75	1,230	90	
		(2) 45.0			2,174	51	2,154	51	2,148	52	2,138	52	2,094	53	1,928	57	1,671	66	1,471	75	1,232	90	

A ** Represents the voltage, 20=208V, 24=240V, 48=480V. Voltage of the KF/KFS unit does not affect the data in this table.
 B NR= Not Recommended, Temperature Rise is above maximum design parameter.
 C The highlighted cells are the factory default torque setting for each model. The ECM motor has 5 field adjustable torque settings, allowing for a wide range of design choices.
 D (1) = Stage 1 Torque Settings (2) = Stage 2 Torque Settings / (2) = Default for Single Stage KFUH
 E Blower: 10" diameter, 8" wide

DIMENSIONAL DATA

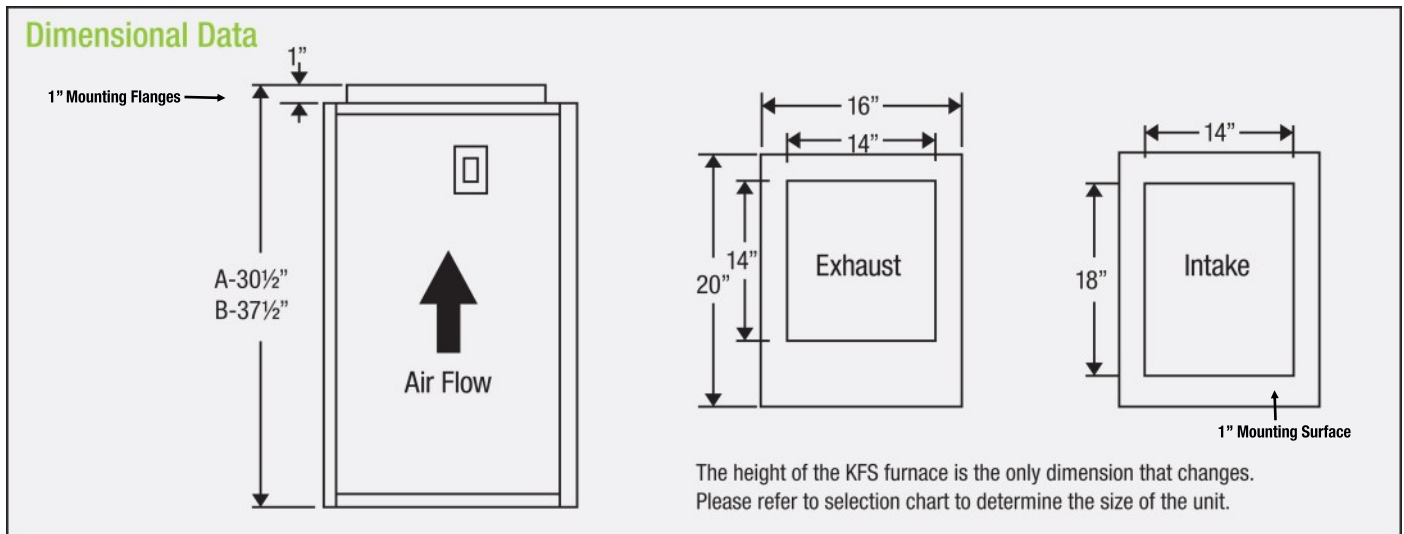

INSTALLATION & GUIDELINES

FIELD WIRING: King furnaces come equipped with 60 amp circuit breakers installed for protection of the furnace internal wiring only. They also serve as a disconnection means when required. A single phase circuit must be brought to each circuit breaker in the furnace as shown in the wiring diagram. The terminals are identified as L1-L2, L3-L4, L5-L6 and L7-L8. A 3 Phase supply would have a 3 Phase Power Supply Terminal Block.

The KW size of the furnace determines how many circuits are required. The furnace power and electrical rating table indicates how many circuits each model furnace requires, the size of the branch circuit protection at the distribution panel and the wire size required from distribution panel to the furnace. If there is any questions-consult your local and national electric codes. All wiring used must be approved for 75°C. NOTE: For 208/240V Furnaces: No wire may have more than 120 VAC potential to ground. For 480V Furnaces: No wire may have more than 277 VAC potential to ground. This must be checked on installation to avoid motor damage. Unit must be grounded by connection of grounding wire from the distribution panel to the terminal provided in furnace. When the line voltage terminal block option is specified for single strike, see wiring diagram for wire size and circuit protection requirements.

CONTROL WIRING: Connect thermostat to terminals R and W for heating, and to R and G for cool air only. This can be done with a single stage heat-cool thermostat or a single stage heat only thermostat and a separate fan-only switch to control the fan-relay (optional) installed on furnaces. Some models of furnace have two stage operation (optional) and are provided with terminals W1 and W2. If a single stage thermostat is used it should be connected to terminals R and W1 and a jumper wire installed from terminals W1 to W2; see enclosed control circuit wiring diagram. Some models of furnace have the 24 VAC power available between terminal C and R for use with external air conditioning blower relay option.

OPERATION: When control thermostat is turned up to demand heat the blower and heating elements should be energized. Furnaces with sequencers installed will have up to 30 seconds delay in start-up. Heat-cool thermostats when turned to cool position should bring on the blower only for cooling air.

KING ELECTRIC FURNACE

1. Your King electric furnace has been designed to distribute heated air to your living quarters when connected to appropriate ducting.
2. All KF/KFS furnaces operate under command of a low voltage wall thermostat
3. Models KFS5 through KFS18 employ one sequencer relay and thus the thermostat heat anticipator should be set at 0.4.
4. Models KFS20 thru KFS35 employ two thermal relays, thus the thermostat heat anticipator should be set at 0.8.

CAUTION

Before turning the furnace on, the heat anticipator in a non-electronic thermostat must be properly set to prevent its failure and to assure comfortable, economical heating.

INSTALLATION AND MAINTENANCE

SEQUENCE OF OPERATION

1. With the thermostat set at 70°F and the temperature drops below 70°F, the thermostat's internal switch closes its contacts. About 45 seconds later the first heating element and the blower turn "ON". After another 30 seconds the second heating element is turned "ON". **For 2-stage models only:** Continuing in 30 second intervals until all the heating elements in the furnace are "ON".
2. When the thermostat is satisfied the "ON" process is reversed with the last element & blower turning "OFF" simultaneously.
3. Because of the many variable affecting heat loss (cold wall, sun rays, drafts, etc.) you may be more comfortable with the thermostat set higher or lower than 70°F it will take some experience to find your comfort setting.
4. Your King electric furnace may be equipped with a cooling coil to accomplish summer cooling. It may also be equipped with an electronic air cleaner to reduce dust pollen and other household respiratory irritabilities.
5. If your furnace does not have an electronic air cleaner you will need to replace the furnace filter several times during the year or whenever it becomes clogged and needs servicing.
6. The furnace cannot deliver warm air unless,
 - a) all electric circuit breakers are turned "ON".
 - b) your furnace filters are clogged with dirt and dust Air is the vehicle for heat transfer, thus in order to deliver warm air an equal amount of cold air must be draw back to the furnace.
 - c) your thermostat heat anticipator is set wrong - see paragraph three and four above.
 - d) your cold air return registers are blocked with furniture, throw rugs, etc.
 - e) your warm air registers are blocked with furniture, throw rugs, etc.
 - f) Your furnace is single stage and you didn't jump W1 & W2.
7. If your furnace is equipped with a cooling coil your "Outdoor Condensing Unit" must be turned "ON" when summer cooling is required; and your thermostat must be switched to the "Cooling position and the thermostat temperature setting should be set at about 76°F, then if too cold, raise temperature, if too hot, lower temperature setting.
 - a) The heat cool thermostat, on furnaces with cooling provisions, has a HEAT/OFF & COOL position. The fan section as an AUTOMATIC and ON position.
 - b) For heating, the system switch must be moved to HEAT position and the fan section should be set to AUTOMATIC.
 - c) For cooling set the system to COOL and the fan section to ON. Thus the fan will run constantly with the outdoor condensing unit running only when your thermostat calls for cooling.
 - d) You may want the fan to run continuously in either HEAT or COOLING. If so, set fan system to ON.
 - e) The OFF position shuts down both heat and cooling and also shuts off the fan.
 - f) In winter don't leave home with the furnace turned OFF. Instead set your thermostat at about 40°F and leave the furnace system in the HEAT position to reduce the possibility of freezing of the indoor plumbing.
8. If your furnace is equipped with an electronic air cleaner it must be cleaned several times during the year. You will want to study the HOME OWNER'S MANUAL supplied with the electronic air cleaner.

FOR USE IN MOBILE HOMES DOWNFLOW INSTALLATION

NOTE: If needed, make sure any return air grill has a free air area of not less than 196 square

1. Select a suitable, centralized location of the furnace: A closet, alcove or utility room.
2. The site selection must have adequate return air capability and must be located directly above existing or planned location of the charge plenum.
3. Cut a 15" x 15" opening in the floor exposing discharge plenum (or its location).
4. Place the base for combustible floor application into the floor opening. Secure it to the floor with screws (at least one on each side).
5. Put the duct connector into the base opening and mark plenum for cutting where the duct connector rests on it.
6. Remove the duct connector and cut to the outside of marking on plenum and remove cut metal.
7. Replace duct connector back down through floor base. Bend alternate pre-cut tabs of duct connector 90°outward. Press duct connector into plenum, and bend remaining tabs into the plenum so that it is firmly attached.
8. If necessary, cut the top of duct connector so that it is below the top of floor base, approximately 1".
9. Make the air duct tight by applying 2" duct tape to the tabbed in portion of duct connector at the plenum opening and around the top of duct connected inside the floor base.
10. Attach the duct connector to floor base using four (4) #8 hex head 1/2" self-tapping screws.
11. Remove air filter from furnace. Set the furnace onto the combustible floor base with the filter end of the furnace facing upward. Replace filter in furnace.
12. Make sure power is off on electrical circuits.
13. Remove door of furnace and bring proper electrical wiring into an appropriate opening provided and connect wiring per instructions on wiring diagram.
14. If needed, make sure any return air grill has a free air area of not less than 196 square inches.

SHALLOW DUCT AREA REQUIREMENTS

Duct Depth	Duct Width
4" (102 mm)	16" (406 mm)
5" (127 mm)	13" (330 mm)
6" (152 mm)	10" (254 mm)

USING OPTIONAL EQUIPMENT

USING OPTIONAL EQUIPMENT

1. AIR CONDITIONING

Your furnace is equipped with all the controls required for the addition of air conditioning (except the heat-cool thermostat). The evaporator coil may be installed by a local contractor in sheet metal plenum of his own manufacture. The coil should be located: Centered over the furnace 4" (102 mm) to 6" (152 mm) above the top of the furnace.

Make sure no air is allowed to bypass the cooling coil during cooling operation. If the discharge opening is a great deal larger than the coil, and the ductwork is correspondingly larger than the coil, you may want to use a bypass damper for heating.

The damper would be closed in summer, directing all air flow through the coil. In winter the damper would be open to allow air to bypass the coil.

Typical air-conditioning field wiring connections are shown in the following diagram:

2. WOOD ELECTRIC COMBINATION

When the electric furnace is used in combination with a wood burning stove, connect a cooling thermostat near the wood burning Stove and use the LOW VOLTAGE TERMINALS R and G. The thermostat in the furnace will then turn on the blower in the electric furnace, sending heat to the rest of the house.

MAINTENANCE

MOTOR: The motor is lubricated for life and needs no oiling.

FILTERS: Size is 16" x 20" x 1" (406.4 mm x 508 mm x 25 mm).

Should be inspected and replaced when dirty. Ordinarily replacement is required twice per heating season and, perhaps, a third time if continuous blower operation is used.

NOTE: Each element has an automatic reset thermal cut-out which is set to open at 176°F (80°C). If it opens, the element will be de-energized until the cut-out resets itself. In addition to that, there is a manual reset thermal cut-out that open at 176F (80°C). This limit is placed farther back and will only trip for major failures like fan failure or inlet blockage. If the manual reset thermal cut-out trips, power to the unit will need to be fully removed so the cut-out can be manually reset.

“WARNING: RISK OF ELECTRIC SHOCK. CAN CAUSE INJURY OR DEATH. DISCONNECT ALL REMOTE ELECTRIC POWER SUPPLIES BEFORE SERVICING.”

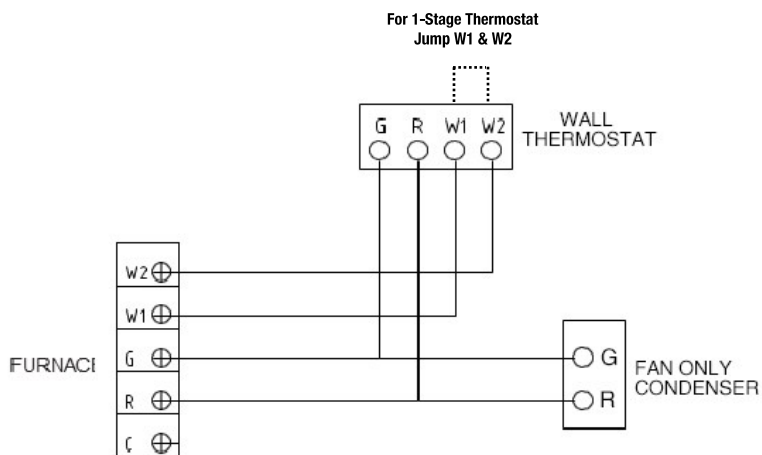

TRIPPED HIGH LIMIT

The reason for the trip should be investigated before re-starting the furnace. The limit usually opens when airflow is reduced because of blocked ductwork, very dirty filters, or fan/motor failure. In order to reset the manual limit, power to the unit will need to be fully disconnected via a circuit breaker or disconnect switch. Once the manual reset thermal cut-out cools down, which can take up to 15 minutes after power is fully disconnected, power can be restored to the unit.

WIRING COLOR CODES				
C	G	R	W1	W2
BLUE	BROWN	YELLOW	RED	BLACK (Optional)

CONTROL WIRING DIAGRAMS

TWO STAGE FURNACE

Paired With A 2-Stage Low Voltage External Thermostat

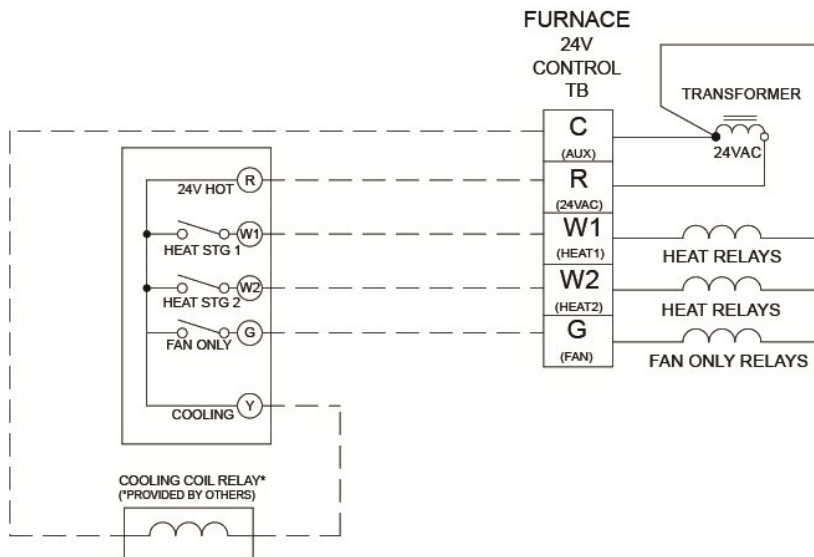

TWO STAGE FURNACE

Paired With A Single Stage Low Voltage External Thermostat

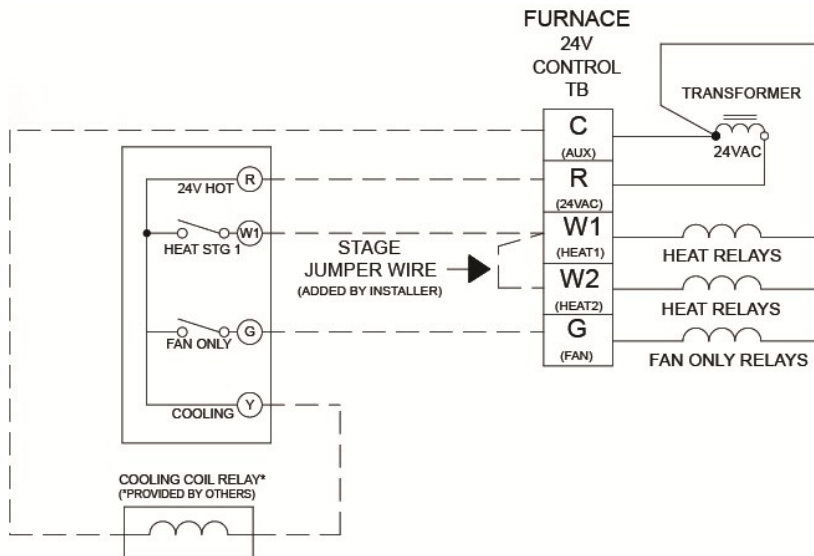

ONE STAGE FURNACE

Paired With A Single Stage Low Voltage External Thermostat

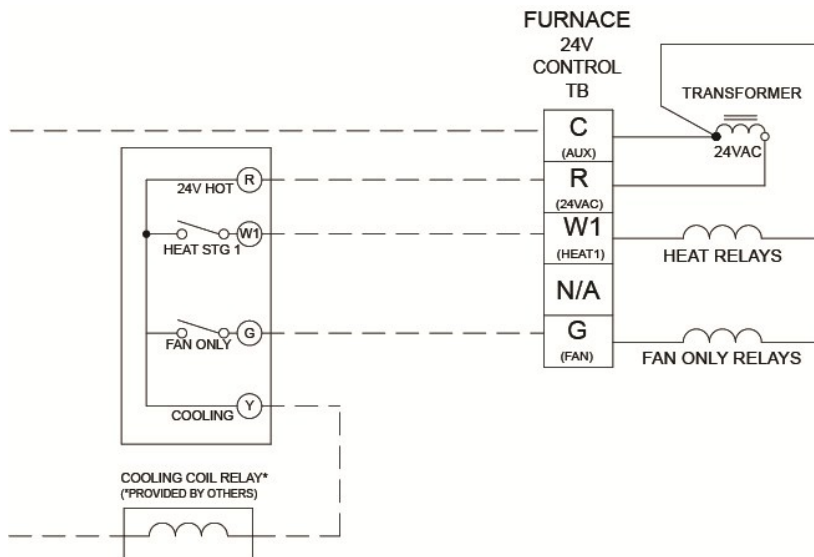

TROUBLESHOOTING

The first step in identifying an operational problem is to determine whether the fault is in the furnace or in the thermostat and/or its connecting wiring.

To help make this determination, the furnace is equipped with a "Thermostat ON" diagnostic light. If the light is "ON", it indicates the thermostat has closed and is calling for heat; the blower should be running. If the light is "OFF", the furnace should not be operating (unless the Continuous Speed switch is set to run the motor continuously).

1. If the furnace will not start:

Turn the thermostat to its highest setting. If the light goes on, the thermostat has closed, so the fault is in the furnace. If the light does not go on, the thermostat or its connecting wiring is the problem.

2. If the furnace will not turn off:

Turn the thermostat to its lowest setting. If the light goes off and the furnace continues to run, the thermostat has opened properly and the fault is in the furnace. If the light stays on, the fault is in the thermostat or its connecting wiring.

After the fault area is isolated by use of the diagnostic light, a check of the following components can be made more efficiently.

SYMPTOM	PROBLEM	SOLUTION
Runs too often, Blows cold air	1. Thermostat heat anticipator set too low 2. CFM of motor set too high 3. Change of motor size from original	1. Replace with adjustable anticipated thermostat. 2. Lower CFM of motor: Red Wire - Low Speed Blue Wire - Medium Speed Black Wire - High Speed 3. KFS5 - 18 should have 1/3HP motor, KFS18-35 should have a 1/3HP motor; 1/2 & 3/4 HP motors are optional
Furnace short cycles before thermostat calls for off	1. Thermostat anticipator set too low 2. Intermittent opening of thermostat 3. Heat element burned out 4. Circuit breaker off 5. Motor overheating	1. Adjust to .04 amps for each sequencer in furnace 2. Repair or replace thermostat 3. Replace 4. Reset 5. Replace
Furnace will not start	1. Stat wire not connected 2. Circuit breaker off 3. 24 Volt transformer burned out 4. Wire connection off or broken wires 5. Reset button tripped 6. Wrong Voltage	1. Repair 2. Reset 3. Replace 4. Repair or Replace 5. Reset 6. Check your power source
Motor will not stop	1. Defective sequencer or contactor	1. Replace
Furnace goes off on high limit	1. Dirty ducts 2. Dirty Air Filter 3. Defective Sequencer 4. Defective Limit Control 5. Power Failure	1. Clean 2. Repair or replace thermostat 3. Replace 4. Reset 5. Replace
Furnace blower making too much air noise	1. Air Filter Dirty 2. Too small of a duct 3. Too small plenum chamber 4. Not enough cold air	1. Replace 2. Enlarge or replace 3. Replace 4. Enlarge
Vibration noise	1. Blower assembly loose 2. Lack of insulation	1. Secure motor and blower cage 2. Wrap furnace & ducts with insulation
Furnace has a buzzing sound when not in use	1. Low voltage transformer defective or loose	1. Replace or tighten
Furnace continues to heat after room is up to set temperature - does not shut off	1. Defective sequencer 2. Defective thermostat 3. Stat wire to ground 4. Motor wires to ground 5. Thermostat accidentally shorted & contacts are welded	1. Replace 2. Replace 3. Repair 4. Repair 5. Replace—Make sure connections are tight

NOTE: When converting from oil, gas, etc., to electric, replace your old low voltage thermostat that has a fixed-heat anticipator with one that has an adjustable heat anticipator.

NOTE:

New Installation Requirements Due to UL Standards Update

The New UL Standard for Electric Furnaces requires to break all incoming power circuits. With this change King Furnace requires that the electrical power to the circuit breakers have the power properly phased into each breaker in order to run properly.

Please read this information to familiarize yourself on the correct way to check your proper Phase relationship to the rest of the wires in your furnace.

Measuring from any two odd numbered lugs should read Zero Volts.
1,3,5,7.

Measuring from any two even numbered lugs should read Zero Volts.
2,4,6,8.

Any odd and even numbered Lugs will read 240 Volts.

Check with a Multi-meter on and not with a light stick.

Test for Correct Phase Before Turning on These Breakers

Use a Volt Meter to Read the Following Voltages on the Input Side of the Breaker.

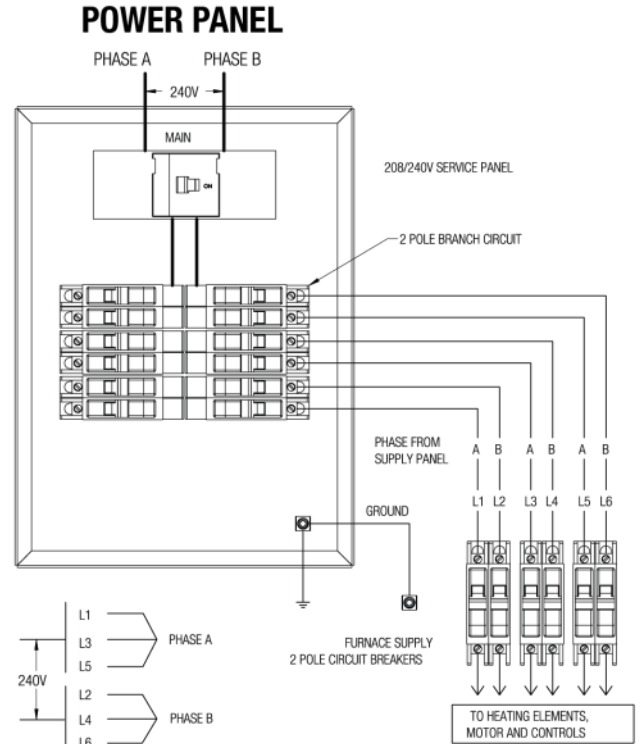
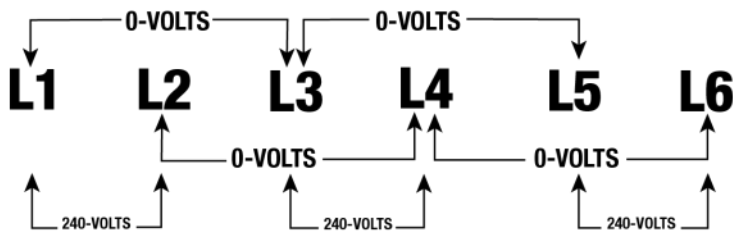

CAUTION ! Furnace must be phased in sequence as shown. Crossing Phase A and Phase B will result in a direct short, causing equipment damage and possible personnel harm or death from electrocution.