



Electronic Furnace KF/KFS ECO2S Series



Model Code:

KFS	24	20	1	2S1	ECM
A	B	C	D	E	F

- A: Series
- B: 24 - 240V 20 - 208V
- C: Kilowatts
- D: 1-phase 3-phase
- E: 2 Stage 2S1= 2 Stage 1-phase
2S3= 2 Stage 3-phase
- F: ECM Motor



- Energy efficient ECM motor
- 2-Stage comfort heating 15% Savings
- Heavy duty open coil elements
- Sequenced heating elements
- Down flow or up flow
- 16" x 20" x 1" inlet filter
- Welded cabinet design
- Horizontal or vertical mount
- Mobile home approved
- Breaker disconnects
- Baked enamel finish
- Extended life
- Standard 24 volt control
- Fan only relay
- Quiet sound insulated cabinet
- 5 Year limited warranty



The KFS ECO2S Electric Furnace

ENERGY SAVINGS meets MAXIMUM COMFORT with the ECM Motor & 2 Stage Heating

The ECO2S Series Model adds a state of the art electronically controlled motor and 2 heating stages for added comfort and Maximum Energy Savings. The KFS ECO2S Series furnace is the quietest and most compact unit available in its class. Ideal for residential applications, and yet powerful enough for commercial and process heating applications as well. It's the perfect choice for both new and replacement installations. The compact design allows it to be installed in either upflow, downflow or horizontal applications. Featuring a maintenance free blower, an insulated cabinet for quiet operation, and heavy gauge coiled nickel-chromium wire heating elements, the KFS furnace will provide years of trouble-free operation.

Motor Features

- Energy Saver
- AFUE 100% (Energy Guide Rating) Most Efficient
- 5 speeds available
- Designed for extended life
- Efficiency up to 80%
- 60 second time delay

- Up to 33% greater efficiency with ECM motor
- Up to 200% greater efficiency with ECM motor in constant fan mode

Heating Features

- 2-Stage Elements & control
- Ni-Chrome Elements
- More even heating

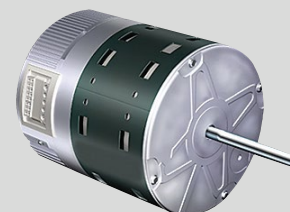

ECM Motor

TWO STAGE COMFORT Why 2 Stage is Better

2 Stage controlled Furnaces allow you to use less energy during mild Spring and Fall temperatures. It's like having a smaller furnace installed just for spring and fall, then when winter hits you have the reserve power of the second heating stage to fight off the cold weather. It also has the benefit of creating more even comfort temperatures.

Note: The Furnace will run a percentage longer to reach the room temperature so the ECM motors efficiency is key to getting the most out of your Furnace.

Two Stage Comfort

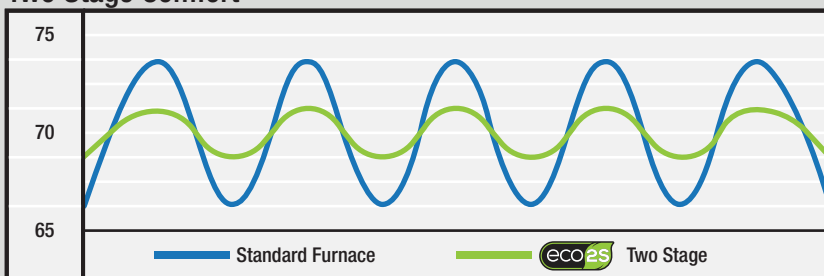

Yearly Savings

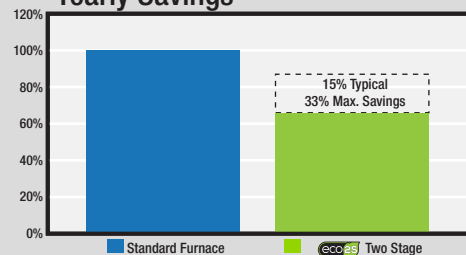

The ECO2S Series is more efficient and will save you up to 33% more per year versus standard furnace motors

- Designed for extended life
- Energy efficient
- Improved reliability
- Cooler operating temperature
- 5 speeds
- 15% 2 Stage

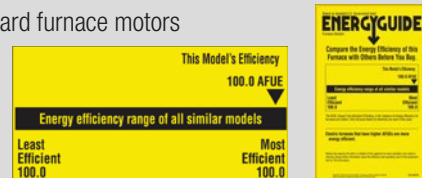

Electronic Furnace KF/KFS ECO2S Series

Ordering Information- single phase

MODEL	BTUH	VOLTS	PHASE	KW	RESISTIVE AMPS	STAGE1	STAGE2	# OF ELEMENTS	INTERNAL CB	MOTOR	MOTOR FLA	SIZE	WT.(lbs)
KFS2004-1-ECM	12,799	208	1	3.8	18	4 kW	*N/A	1	60	1/3HP	2.7	Fig. A	57.0
KFS2005-1-ECM	17,065	208	1	5.0	24	5 kW	*N/A	1	60	1/3HP	2.7	Fig. A	57.0
KFS2008-1-2S1-ECM	27,304	208	1	8	38	4.25	3.75 kW	2	60	1/3HP	2.7	Fig. A	57.0
KFS2010-1-2S1-ECM	34,130	208	1	10.0	48	5 kW	5 kW	2	60	1/3HP	2.7	Fig. A	65.0
KFS2012-1-2S1-ECM	39,238	208	1	11.5	55.3	7.5 kW	4 kW	3	60	1/3HP	2.7	Fig. A	74.0
KFS2015-1-2S1-ECM	51,195	208	1	15.0	72	10 kW	5 kW	3	60+60	1/3HP	2.7	Fig. A	74.0
KFS2020-1-2S1-ECM	68,260	208	1	20.0	96	10 kW	10kW	4	60+60	1/2HP	3.9	Fig. B	76.0
KFS2025-1-2S1-ECM	85,325	208	1	25.0	120	15 kW	10 kW	5	60+60+60	1/2HP	6.0	Fig. B	81.0
KFS2030-1-2S1-ECM	102,390	208	1	30.0	144	20 kW	10 kW	6	60+60+60	3/4HP	6.0	Fig. B	85.0
KFS2404-1-ECM	13,652	240	1	4.0	17	4 kW	*N/A	1	60	1/3HP	2.9	Fig. A	57.0
KFS2405-1-ECM	17,065	240	1	5.0	21	5 kW	*N/A	1	60	1/3HP	2.9	Fig. A	57.0
KFS2408-1-2S1-ECM	27,304	240	1	8.0	33	4 kW	4 kW	2	60	1/3HP	2.9	Fig. A	57.0
KFS2410-1-2S1-ECM	34,130	240	1	10.0	42	5kW	5 kW	2	60	1/3HP	2.9	Fig. A	65.0
KFS2412-1-2S1-ECM	40,956	240	1	12.0	50	5.75 kW	5.75 kW	2	60	1/3HP	2.9	Fig. A	74.0
KFS2415-1-2S1-ECM	51,195	240	1	15.0	63	10 kw	5 kW	3	60+60	1/3HP	2.9	Fig. A	74.0
KFS2418-1-2S1-ECM	58,874	240	1	17.3	72	11.5 kw	5.75 kW	3	60+60	1/3HP	2.9	Fig. A	74.0
KFS2420-1-2S1-ECM	68,260	240	1	20.0	83	10kw	10 kW	4	60+60	1/2HP	4.2	Fig. B	76.0
KFS2425-1-2S1-ECM	85,325	240	1	25.0	104	15 kW	10 kW	5	60+60+60	1/2HP	4.2	Fig. B	81.0
KFS2430-1-2S1-ECM	102,390	240	1	30.0	125	20 kW	10 kW	6	60+60+60	3/4HP	6.2	Fig. B	85.0
KFS2435-1-2S1-ECM	117,749	240	1	34.5	144	23 kW	11.5 kW	6	60+60+60	3/4HP	6.2	Fig. B	85.0
KF4804-1-ECM	13,652	480	1	4.0	8	4 kW	*N/A	1	NO	1/3HP	0.8	Fig. A	57.0
KF4805-1-ECM	17,065	480	1	5.0	10	5 kW	*N/A	1	NO	1/3HP	0.8	Fig. A	57.0
KF4808-1-2S1-ECM	27,304	480	1	8.0	17	4 kW	4 kW	2	NO	1/3HP	0.8	Fig. A	57.0
KF4810-1-2S1-ECM	34,130	480	1	10.0	21	5 kW	5 kW	2	NO	1/3HP	0.8	Fig. A	65.0
KF4812-1-2S1-ECM	40,956	480	1	12.0	25	8 kW	4 kW	3	NO	1/3HP	0.8	Fig. A	74.0
KF4815-1-2S1-ECM	51,195	480	1	15.0	31	10 kW	5 kW	3	NO	1/3HP	0.8	Fig. A	74.0
KF4818-1-2S1-ECM	58,874	480	1	17.3	36	11.5 kW	5.75 kW	3	NO	1/3HP	0.8	Fig. A	74.0
KF4820-1-2S1-ECM	68,260	480	1	20.0	42	15 kW	5 kW	4	NO	1/2HP	1.2	Fig. B	76.0
KF4825-1-2S1-ECM	85,325	480	1	25.0	52	15 kW	10 kW	5	NO	1/2HP	1.2	Fig. B	81.0
KF4830-1-2S1-ECM	102,390	480	1	30.0	63	20 kW	10 kW	6	NO	3/4HP	1.7	Fig. B	85.0
KF4835-1-2S1-ECM	117,749	480	1	34.5	72	23 kW	11.5 kW	6	NO	3/4HP	1.7	Fig. B	85.0

*Not Available in 2-Stage.

Ordering Information- three phase

MODEL	BTUH	VOLTS	PHASE	KW	RESISTIVE AMPS	STAGE1	STAGE2	# OF ELEMENTS	INTERNAL CB	MOTOR	MOTOR FLA	SIZE	WT.(lbs)
KFS2005-3-ECM	17,065	208	3	5.0	14	5 kW	*N/A	1	60	1/3HP	2.7	Fig. A	57.0
KFS2007-3-2S3-ECM	25,598	208	3	7.5	21	3.8 kW	3.8 kW	2	60	1/3HP	2.7	Fig. A	57.0
KFS2010-3-2S3-ECM	34,130	208	3	10.0	28	5 kW	5 kW	2	60	1/3HP	2.7	Fig. A	65.0
KFS2012-3-2S3-ECM	39,238	208	3	11.5	32	7.5 kW	4 kW	3	60	1/3HP	2.7	Fig. A	74.0
KFS2015-3-2S3-ECM	51,195	208	3	15.0	42	10 kW	5 kW	3	60	1/3HP	2.7	Fig. A	74.0
KFS2020-3-2S3-ECM	68,260	208	3	20.0	56	15 kW	5 kW	4	60+60	1/2 HP	3.9	Fig. B	76.0
KFS2025-3-2S3-ECM	85,325	208	3	25.0	69	15 kW	10 kW	5	60+60	3/4 HP	6.0	Fig. B	81.0
KFS2030-3-2S3-ECM	102,390	208	3	30.0	83	15 kW	15 kW	6	60+60	3/4 HP	6.0	Fig. B	85.0
KFS2405-3-ECM	17,065	240	3	5.0	12	5 kW	*N/A	1	60	1/3HP	2.9	Fig. A	57.0
KFS2410-3-2S3-ECM	34,130	240	3	10.0	24	5 kW	5 kW	2	60	1/3HP	2.9	Fig. A	65.0
KFS2412-3-2S3-ECM	40,956	240	3	12.0	29	6.5 kW	5.5 kW	3	60	1/3HP	2.9	Fig. A	74.0
KFS2415-3-2S3-ECM	51,195	240	3	15.0	36	10 kW	5 kW	3	60	1/3HP	2.9	Fig. A	74.0
KFS2418-3-2S3-ECM	58,874	240	3	17.3	42	12.3 kW	5 kW	3	60	1/3HP	2.9	Fig. A	74.0
KFS2420-3-2S3-ECM	68,260	240	3	20.0	48	15 kW	5 kW	4	60+60	1/2 HP	4.2	Fig. B	76.0
KFS2425-3-2S3-ECM	85,325	240	3	25.0	60	15 kW	10 kW	5	60	1/2 HP	4.2	Fig. B	81.0
KFS2430-3-2S3-ECM	102,390	240	3	30.0	72	15 kW	15kW	6	60+60	3/4 HP	6.2	Fig. B	85.0
KFS2435-3-ECM	117,749	240	3	34.5	83	17.25 kW	17.25 kW	6	60+60	3/4 HP	6.2	Fig. B	85.0
KF4805-3-ECM	17,065	480	3	5.0	6	5 kW	*N/A	1	NO	1/3HP	0.8	Fig. A	57.0
KF4810-3-2S3-ECM	34,130	480	3	10.0	12	5 kW	5 kW	2	NO	1/3HP	0.8	Fig. A	65.0
KF4815-3-2S3-ECM	51,195	480	3	15.0	18	10 kW	5 kW	3	NO	1/3HP	0.8	Fig. A	74.0
KF4818-3-ECM	58,874	480	3	17.3	21	17.3 kW	*N/A	3	NO	1/3HP	0.8	Fig. A	74.0
KF4820-3-2S3-ECM	68,260	480	3	20.0	24	15 kW	5 kW	4	NO	1/2HP	1.2	Fig. B	76.0
KF4825-3-2S3-ECM	85,325	480	3	25.0	30	15 kW	10 kW	5	NO	1/2HP	1.2	Fig. B	81.0
KF4830-3-2S3-ECM	102,390	480	3	30.0	36	20 kW	10 kW	6	NO	3/4HP	1.7	Fig. B	85.0
KF4835-3-2S3-ECM	117,749	480	3	34.5	42	17.25 kW	17.25 kW	6	NO	3/4HP	1.7	Fig. B	85.0

*Not Available in 2-Stage.

Electronic Furnace KF/KFS ECO2S Series

Accessories

MODEL	UPC	DESCRIPTION	WEIGHT(lbs.)
KFS-4PJB	20185	* 4-Pole Jumper Bar - 15kW to 20kW	.05
KFS-6PJB	20184	* 6-Pole Jumper Bar - 25kW to 30kW	.05
KFSSB	20182	Outlet Collar (To provide 1" clearance for combustible floors)	5
KFS-Q02C	20181	Small Cooling Cabinet 16" L x 22" W x 19½" H - 13 lbs.	25
KFS-Q03C	20180	Large Cooling Cabinet 18" L x 22" W x 19½" H - 15 lbs.	25
KFS-DT	20186	Transition from 14" x 14" Outlet to 12" round	25

* For single strike connection

DIMENSIONAL CLEARANCE	
Cabinet Sides	1 in.
Cabinet Front	0 in.
Exhaust duct within 3 feet of furnace	1 in.
Return Air Plenum	0 in.

Factory Installed Options

ADD SUFFIX:	DESCRIPTION
-DS32	32 Amp, 3-Pole Disconnect Switch w/ Padlock Provision
-DS63	63 Amp, 3-Pole Disconnect Switch w/ Padlock Provision
-DS80	80 Amp, 3-Pole Disconnect Switch w/ Padlock Provision
-DS100	100 Amp, 3-Pole Disconnect Switch w/ Padlock Provision
-3/4HP	Sub 3/4HP Motor for 20kW & 25kW Models Only

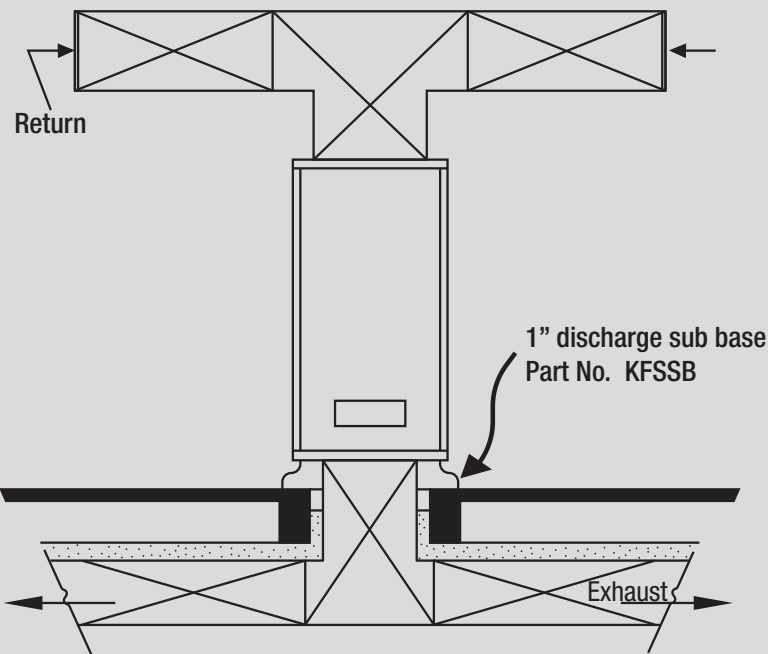

DOWN FLOW

UP FLOW

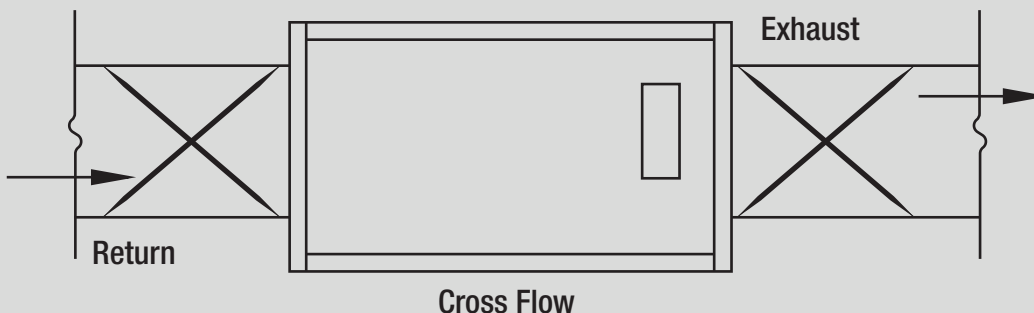
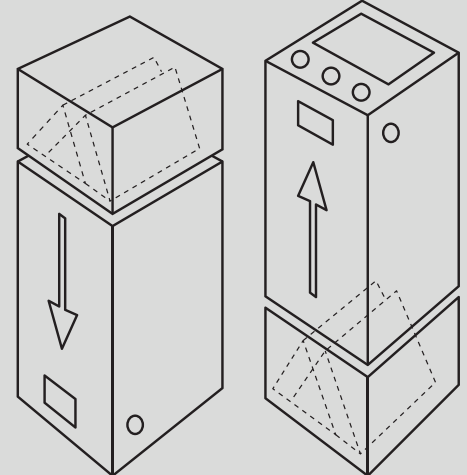

Electronic Furnace KF/KFS ECO2S Series

Dimensional Data

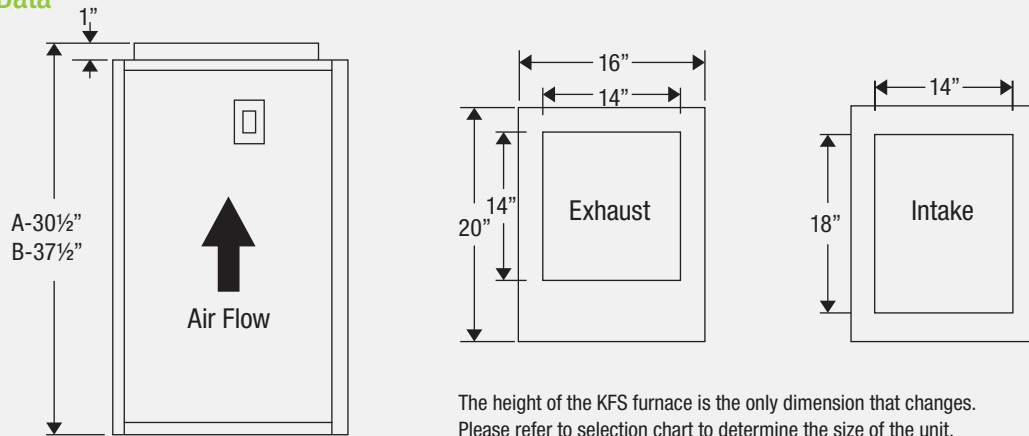

The height of the KFS furnace is the only dimension that changes. Please refer to selection chart to determine the size of the unit.

Air Flow Chart (For 4 to 17.25kW Units with 1/3HP ECM Motor)

MODEL	KW	TORQUE	0.1"WC		0.2"WC		0.3"WC		0.4"WC		0.5"WC		0.6"WC		0.7"WC		0.8"WC		0.9"WC		1.0"WC			
			CFM	RISE	CFM	RISE	CFM	RISE	CFM	RISE	CFM	RISE	CFM	RISE	CFM	RISE	CFM	RISE	CFM	RISE	CFM	RISE	CFM	RISE
KF/KFS**04	4	(2) 6.8	832	15	708	18	593	21	510	25	442	29	374	34	320	39	278	46						
		9.4	1,030	12	919	14	826	15	739	17	658	19	594	21	546	23	494	26						
		12.0	1,168	11	1,085	12	992	13	902	14	835	15	783	16	736	17	700	18						
		17.0	1,376	9	1,320	10	1,259	10	1,189	11	1,116	11	1,060	12	1,016	12	987	13						
		20.0	1,582	8	1,536	8	1,462	9	1,380	9	1,275	10	1,192	11	1,107	11	1,043	12						
KF/KFS**05	5	(2) 6.8	832	19	708	22	593	27	510	31	442	36	374	42	320	49	278	57						
		9.4	1,030	15	919	17	826	19	739	21	658	24	594	27	546	29	494	32						
		12.0	1,168	14	1,085	15	992	16	902	18	835	19	783	20	736	21	700	23						
		17.0	1,376	11	1,320	12	1,259	13	1,189	13	1,116	14	1,060	15	1,016	16	987	16						
		20.0	1,582	10	1,536	10	1,462	11	1,380	11	1,275	12	1,192	13	1,107	14	1,043	15						
KF/KFS**08	8	(1) 6.8	832	30	708	36	593	43	510	50	442	57	374	68	320	79	278	91						
		(2) 9.4	1,030	25	919	27	826	31	739	34	658	38	594	43	546	46	494	51						
		12.0	1,168	22	1,085	23	992	25	902	28	835	30	783	32	736	34	700	36						
		17.0	1,376	18	1,320	19	1,259	20	1,189	21	1,116	23	1,060	24	1,016	25	987	26						
		20.0	1,582	16	1,536	16	1,462	17	1,380	18	1,275	20	1,192	21	1,107	23	1,043	24						
KF/KFS**10	10	(1) 6.8	832	38	708	45	593	53	510	62	442	71	374	84	320	99	278	NR						
		(2) 9.4	1,030	31	919	34	826	38	739	43	658	48	594	53	546	58	494	64						
		12.0	1,168	27	1,085	29	992	32	902	35	835	38	783	40	736	43	700	45						
		17.0	1,376	23	1,320	24	1,259	25	1,189	27	1,116	28	1,060	30	1,016	31	987	32						
		20.0	1,582	20	1,536	21	1,462	22	1,380	23	1,275	25	1,192	27	1,107	29	1,043	30						
KF/KFS**12	12	6.8	832	46	708	54	593	64	510	74	442	86	374	101	320	NR	278	NR						
		(1) 9.4	1,030	37	919	41	826	46	739	51	658	58	594	64	546	69	494	77						
		(2) 12.0	1,168	32	1,085	35	992	38	902	42	835	45	783	48	736	52	700	54						
		17.0	1,376	28	1,320	29	1,259	30	1,189	32	1,116	34	1,060	36	1,016	37	987	38						
		20.0	1,582	24	1,536	25	1,462	26	1,380	27	1,275	30	1,192	32	1,107	34	1,043	36						
KF/KFS**15	15	6.8	832	57	708	67	593	80	510	93	442	107	374	NR	320	NR	278	NR						
		(1) 9.4	1,030	46	919	52	826	57	739	64	658	72	594	80	546	87	494	96						
		(2) 12.0	1,168	41	1,085	44	992	48	902	53	835	57	783	61	736	64	700	68						
		17.0	1,376	34	1,320	36	1,259	38	1,189	40	1,116	42	1,060	45	1,016	47	987	48						
KF/KFS**18	17.25	20.0	1,582	30	1,536	31	1,462	32	1,380	34	1,275	37	1,192	40	1,107	43	1,043	45						
		6.8	832	66	708	77	593	92	510	107	442	NR	374	NR	320	NR	278	NR						
		(1) 9.4	1,030	53	919	59	826	66	739	74	658	83	594	92	546	100	494	110						
		12.0	1,168	47	1,085	50	992	55	902	60	835	65	783	70	736	74	700	78						
		(2) 17.0	1,376	40	1,320	41	1,259	43	1,189	46	1,116	49	1,060	51	1,016	54	987	55						

A ** Represents the voltage, 20=208V, 24=240V, 48=480V. Voltage of the KF/KFS unit does not affect the data in this table.

B NR= Not Recommended, Temperature Rise is above maximum design parameter.

C The highlighted cells are the factory default torque setting for each model. The ECM motor has 5 field adjustable torque settings, allowing for a wide range of design choices.

D (1) = Stage 1 Torque Settings (2) = Stage 2 Torque Settings / (2) = Default for Single Stage KFUH

E Blower: 10" diameter, 8" wide

Electronic Furnace KF/KFS ECO2S Series

Air Flow Chart (For 20 to 25kW Units with 1/2HP ECM Motor)

MODEL	KW	0.1"WC		0.2"WC		0.3"WC		0.4"WC		0.5"WC		0.6"WC		0.7"WC		0.8"WC		0.9"WC		1.0"WC			
		TORQUE	CFM	RISE	CFM	RISE	CFM	RISE	CFM	RISE	CFM	RISE	CFM	RISE	CFM	RISE	CFM	RISE	CFM	RISE	CFM	RISE	
KF/KFS**20	20			(F)		(F)		(F)		(F)		(F)		(F)		(F)		(F)		(F)		(F)	
		(1) 15.5			1,258	50	1,262	50	1,193	53	1,132	56	1,054	60	910	69	834	76	821	77	705	90	
		(2) 19.0			1,466	43	1,419	45	1,300	49	1,285	49	1,218	52	1,180	54	1,015	62	979	65	934	68	
		22.5			1,575	40	1,570	40	1,564	40	1,363	46	1,347	47	1,284	49	1,256	50	1,200	53	1,152	55	
		26.0			1,690	37	1,679	38	1,640	39	1,546	41	1,472	43	1,430	44	1,378	46	1,358	47	1,315	48	
KF/KFS**25	25	15.5			1,258	63	1,262	63	1,193	66	1,132	70	1,054	75	910	87	834	95	821	96	705	NR	
		19.0			1,466	54	1,419	56	1,300	61	1,285	61	1,218	65	1,180	67	1,015	78	979	81	934	85	
		(1) 22.5			1,575	50	1,570	50	1,564	51	1,363	58	1,347	59	1,284	62	1,256	63	1,200	66	1,152	69	
		(2) 26.0			1,690	47	1,679	47	1,640	48	1,546	51	1,472	54	1,430	55	1,378	57	1,358	58	1,315	60	
		30.0			1,771	45	1,766	45	1,723	46	1,728	46	1,569	50	1,542	51	1,522	52	1,487	53	1,415	56	

A ** Represents the voltage, 20=208V, 24=240V, 48=480V. Voltage of the KF/KFS unit does not affect the data in this table.

B NR= Not Recommended, Temperature Rise is above maximum design parameter.

C The highlighted cells are the factory default torque setting for each model. The ECM motor has 5 field adjustable torque settings, allowing for a wide range of design choices.

D (1) = Stage 1 Torque Settings (2) = Stage 2 Torque Settings / (2) = Default for Single Stage KFUH

E Blower: 10" diameter, 8" wide

Air Flow Chart (For 20 to 25kW Units with OPTIONAL 3/4HP ECM Motor)

MODEL	KW	0.1"WC		0.2"WC		0.3"WC		0.4"WC		0.5"WC		0.6"WC		0.7"WC		0.8"WC		0.9"WC		1.0"WC			
		TORQUE	CFM	RISE	CFM	RISE	CFM	RISE	CFM	RISE	CFM	RISE	CFM	RISE	CFM	RISE	CFM	RISE	CFM	RISE	CFM	RISE	
KF/KFS**20	20			(F)		(F)		(F)		(F)		(F)		(F)		(F)		(F)		(F)		(F)	
		(1) 26.0			1,592	40	1,592	40	1,581	40	1,551	41	1,529	41	1,496	42	1,432	44	1,353	47	1,231	51	
		30.0			1,789	35	1,758	36	1,716	37	1,650	38	1,598	40	1,552	41	1,451	41	1,451	44	1,282	49	
		(2) 35.0			1,814	35	1,819	35	1,828	35	1,866	34	1,849	34	1,794	35	1,688	37	1,561	40	1,316	48	
		40.5			2,080	30	2,122	30	2,082	30	2,054	31	1,916	33	1,814	35	1,700	37	1,482	43	1,230	51	
KF/KFS**25	25	15.5			1,592	50	1,592	50	1,581	50	1,551	51	1,529	52	1,496	53	1,432	55	1,353	58	1,231	NR	
		30.0			1,789	44	1,758	45	1,716	46	1,692	47	1,650	48	1,598	49	1,552	51	1,451	54	1,282	62	
		(2) 35.0			1,814	44	1,819	43	1,828	43	1,866	42	1,849	43	1,794	44	1,688	47	1,561	51	1,316	60	
		40.5			2,080	38	2,122	37	2,082	38	2,054	38	1,916	41	1,814	44	1,700	46	1,482	53	1,230	64	
		45.0			2,174	36	2,154	37	2,139	37	2,138	37	2,094	38	1,928	41	1,671	47	1,471	54	1,232	64	

A ** Represents the voltage, 20=208V, 24=240V, 48=480V. Voltage of the KF/KFS unit does not affect the data in this table.

B NR= Not Recommended, Temperature Rise is above maximum design parameter.

C The highlighted cells are the factory default torque setting for each model. The ECM motor has 5 field adjustable torque settings, allowing for a wide range of design choices.

D (1) = Stage 1 Torque Settings (2) = Stage 2 Torque Settings / (2) = Default for Single Stage KFUH

E Blower: 10" diameter, 8" wide

Air Flow Chart (For 30 to 35kW Units with 3/4HP ECM Motor)

MODEL	KW	0.1"WC		0.2"WC		0.3"WC		0.4"WC		0.5"WC		0.6"WC		0.7"WC		0.8"WC		0.9"WC		1.0"WC			
		TORQUE	CFM	RISE	CFM	RISE	CFM	RISE	CFM	RISE	CFM	RISE	CFM	RISE	CFM	RISE	CFM	RISE	CFM	RISE	CFM	RISE	
KF/KFS**30	30			(F)		(F)		(F)		(F)		(F)		(F)		(F)		(F)		(F)		(F)	
		(1) 26.0			1,592	60	1,592	60	1,581	60	1,551	61	1,529	62	1,496	63	1,432	NR	1,353	NR	1,231	NR	
		30.0			1,789	53	1,758	54	1,716	55	1,692	56	1,650	57	1,598	59	1,552	61	1,451	65	1,282	74	
		35.0			1,814	52	1,819	52	1,828	52	1,866	51	1,849	51	1,794	53	1,688	56	1,561	61	1,316	72	
		(2) 40.5			2,080	46	2,122	45	2,082	46	2,054	46	1,916	49	1,814	52	1,700	56	1,482	64	1,230	77	
KF/KFS**35	35	26.0			1,592	69	1,592	69	1,581	60	1,551	71	1,529	72	1,496	NR	1,432	NR	1,353	NR	1,231	NR	
		(1) 30.0			1,789	62	1,758	63	1,716	64	1,692	65	1,650	67	1,598	69	1,552	71	1,451	NR	1,282	NR	
		35.0			1,814	61	1,819	61	1,828	60	1,866	59	1,849	60	1,794	62	1,688	66	1,561	71	1,316	84	
		40.5			2,080	53	2,122	52	2,082	53	2,054	54	1,916	58	1,814	61	1,700	65	1,482	75	1,230	90	
		(2) 45.0			2,174	51	2,154	51	2,148	52	2,138	52	2,094	53	1,928	57	1,671	66	1,471	75	1,232	90	

A ** Represents the voltage, 20=208V, 24=240V, 48=480V. Voltage of the KF/KFS unit does not affect the data in this table.

B NR= Not Recommended, Temperature Rise is above maximum design parameter.

C The highlighted cells are the factory default torque setting for each model. The ECM motor has 5 field adjustable torque settings, allowing for a wide range of design choices.

D (1) = Stage 1 Torque Settings (2) = Stage 2 Torque Settings / (2) = Default for Single Stage KFUH

E Blower: 10" diameter, 8" wide

Electronic Furnace KF/KFS ECO2S Series

Internal Diagram - exploded view

Smart Heating Solutions

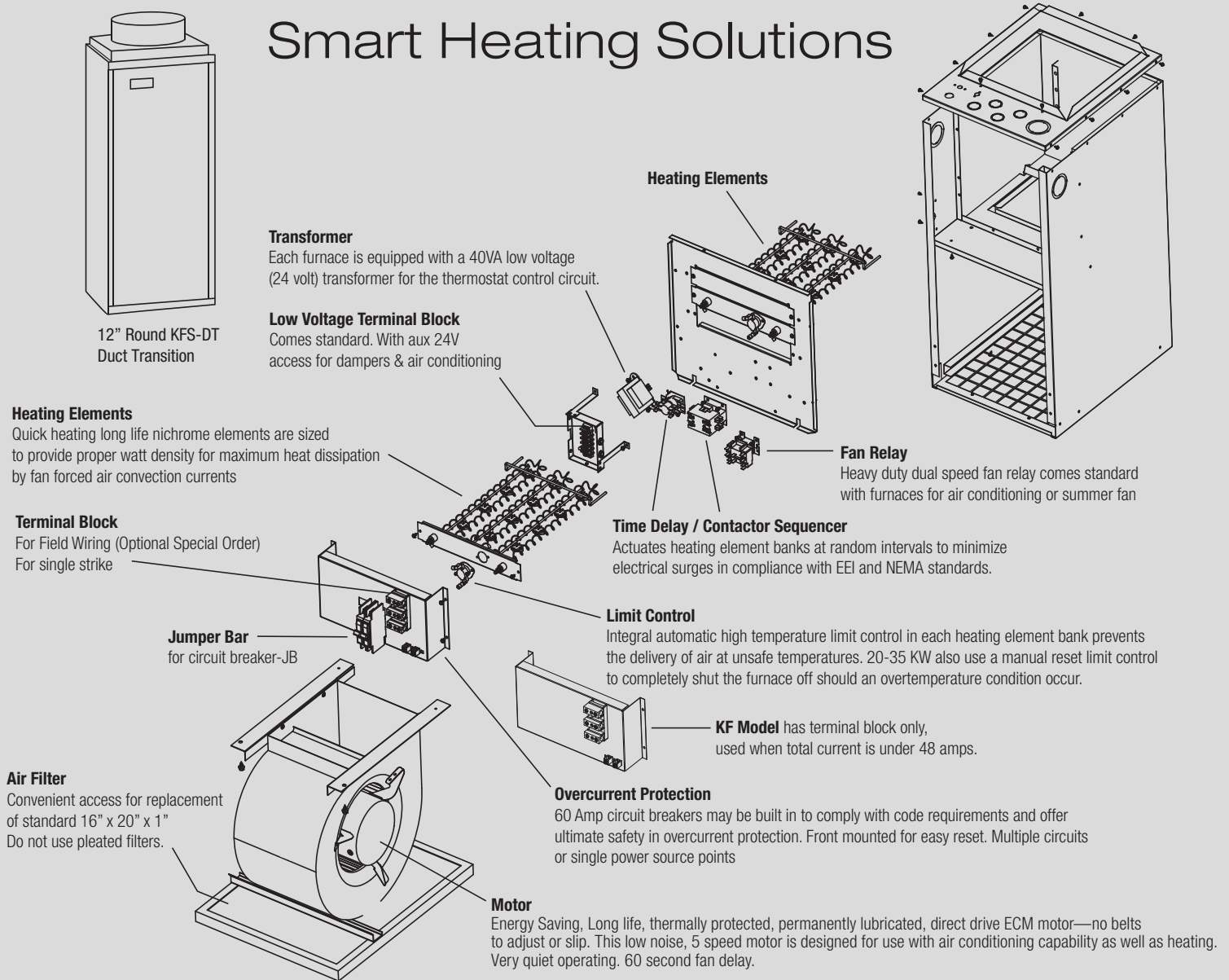

Engineering Specifications

Contractor shall supply and install KFS ECO2S Series electric furnaces manufactured by King Electrical Mfg. Company. Furnaces shall be of the wattage and voltage as indicated on the plans.

Transformer: Each furnace is equipped with a heavy duty low voltage (40 VA) transformer for the thermostat control circuit.

Time Delay Sequencer: Actuates heating element banks to minimize electrical surges in compliance with E.E.I. and N.E.M.A. standards.

Heating Elements: Quick heating, long life Ni-Chrome elements are sized to provide proper watt density for maximum heat dissipation.

Terminal Block: For field wiring (optional special order) KFSTB Single Strike Connection. Takes multiple circuits into a single feed.

Air Filter: Convenient access for replacement of standard 16" x 20" x 1" filter. Do not use pleated filters.

Motor: Energy Saving, Long life, thermally protected, permanently lubricated, direct drive ECM motor—no belts to adjust or slip.

This low noise, 5 speed motor is designed for use with air conditioning capability as well as heating. Very quiet operating. 60 second fan delay.

Overcurrent Protection: 208 and 240 volt KFS models have 60 amp circuit breakers.

Limit Control: Integral automatic high temperature limit control in each heating element bank prevents the delivery of air at unsafe temperatures. 20-35 KW models use a manual reset limit control to completely shut the furnace off should an unsafe temperature occur. Summer fan only operation. Fan can be run independently from heating. Mobile Home approved.

Unique Fan Orifice: Louver directs air over all heating elements and side walls evenly ensuring longer life performance.

Low Voltage Terminal Block: 24 Volt control screw terminals.

Approvals: cULus (E48864) USA and Canada