

Garage/Shop Heater EKB Series



Model Code:

EKB	24	40	TB
A	B	C	D

A: Series
 B: 20 - 208V 24 - 240V
 C: Watts (5000)
 D: TB- Thermostat & Bracket



- Quick heat element
- Long life unit bearing motor
- Patented Smart Limit® protection
- Aluminum fan blade
- Built-in thermostat
- Universal mounting bracket
- Standard color: black textured finish
- Safety sensor on each element
- 1-year limited warranty



The EKB Garage/Shop Heater

The EKB is designed to be an affordable, high-capacity garage / shop heater. Combining King's patented Smart Limit safety technology with dual NiChrome coil elements for rapid heat transfer, the EKB is ideal for many residential applications. The flow-through design efficiently moves air by pulling air from the back and sides of the heater and discharges it out the front, easily heating a large space. The built-in thermostat has a temperature range from 40 to 85 degrees. The universal mounting bracket can be wall or ceiling mounted at a minimum of 6 feet above the floor. Good air distribution and comfort is achieved by swiveling the bracket to specific work areas.

Ordering Information

	MODEL	UPC	kilo WATTS	BTUH (000)	PHASE	VOLTS	AMPS	CFM	TEMP. RISE	AIR THROW	MAX MOUNT HEIGHT	WT. (lbs.)
208V	EKBP2050TB	16501	5000	17,065	1	208	24	270	59°F	12 ft.	8 ft.	14
	EKBP2040TB	16503	3750	12,799	1	208	18	270	44°F	12 ft.	8 ft.	14
240V	EKBP2450TB	16500	5000	17,065	1	240/208*	20/18	270	59°F	12 ft.	8 ft.	14
	EKBP2440TB	16502	3850	13,140	1	240/208*	16/13.9	270	46°F	12 ft.	8 ft.	14

*Approved for 208V operation. Heater will draw 13% less Amps and 25% less wattage

Engineering Specifications

Heating Elements: Rigid Muscovite Mica construction with 80-20 NiChrome heating wire provides quick heating without cold air start ups, heat is wiped from elements as fans slows to a stop. Manual reset Safety sensor on each element.

Thermostat: Factory installed single pole operation range 40 to 85 degrees F.

Unit Bearing Motor: Permanently lubricated, cast aluminum unit bearing, 6-watt output 4 pole motor, 1550 rpm, 20 cc oil supply.

Mounting Bracket: 18 ga steel, multiple mounting options - ceiling/wall.

CFM: 270 Maximum

Thermal Overload: Heaters shall be equipped with King's patented thermal overload Smart Limit Protection®, which disconnects elements and motor in the event normal operating temperatures are exceeded.

If thermal overload trips due to abnormal operating temperatures, thermal overload shall remain open until manually reset by turning the heater off for 15 minutes. U.S. PATENT #6,748,163 B2 • CIPO PATENT #2,393,882

Case: 22 ga steel, inlet and outlet perforation, special side and top safety air inlets.

Exterior: Durable textured finish.

Approval: cULus (E41422)

Garage/Shop Heater EKB Series

Dimensional Data

EKB Unit Heater

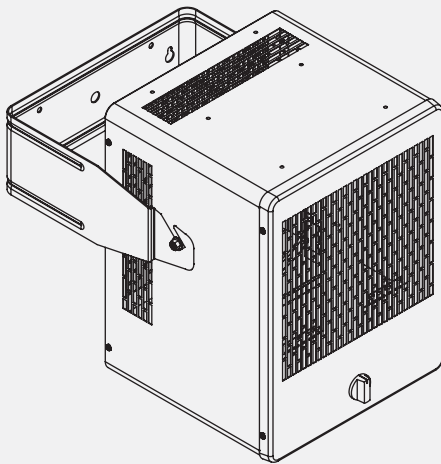

Heater case size
w/o bracket
Height: 13 5/8 in. / 34.6 cm
Width: 10 3/8 in. / 26.35 cm
Depth: 9 3/9 in. / 24.76 cm

Maximum Outside Dims
W/bracket and stat
Height: 18 3/4 in. / 47.62 cm
Width: 11 3/8 in. / 28.90 cm
Depth: 10 5/8 in. / 26.98 cm

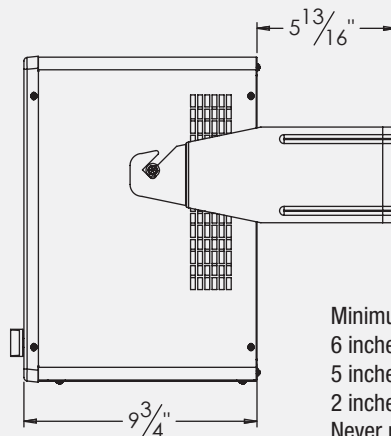
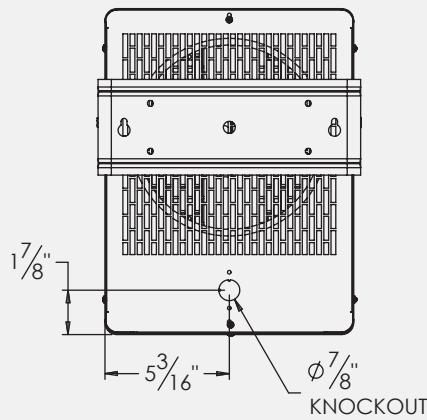
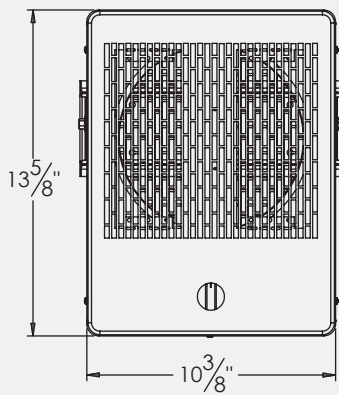

Bracket Information

Hole Sizes
* 1/2 in. / 1.27 cm 3 holes
+ 1/4 in. / .63 cm 4 holes

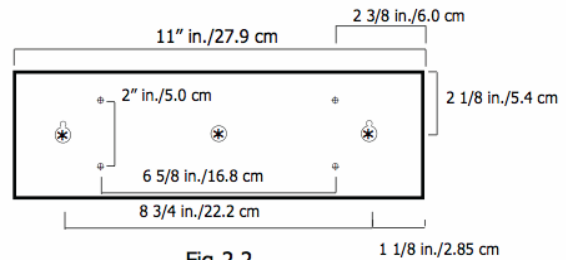
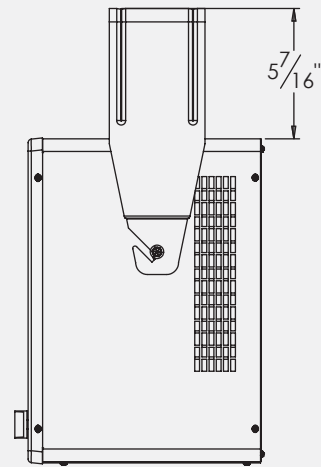

Fig 2.2



Minimum clearances from walls and ceiling
6 inches / 15.24 cm to the side
5 inches / 12.7 cm from the back
2 inches / 5.08 cm from ceiling
Never point heater at ceiling
Maintain clearance of at least 3 ft. in front
of heat outlet

MINIMUM CLEARANCE

From combustibles: 18" from front,
2" from top, 6" from sides
and 5" from rear.