



# Compact Unit Heater KBP PlatinumX BMS Series



### Model Code:

**KBP 48 06 -3MP -MB -PLTMX -BMS**  
**A B C D E F G**

- A: Series**
- B: 20 - 208V, 24 - 240/208V  
27 - 277V, 48 - 480V**
- C: Watts (950 to 5700)**
- D: -1 = Single Phase  
-3 = Three Phase  
-3MP = 1-3 Phase**
- E: Mounting Bracket (Included)**
- F: -PLTMX = 1-Stage Electronic Control  
+ 24V Remote Stat Provision**
- G: Compatible with BMS Systems**



- Energy-Saving PlatinumX electronic temperature controller
- Hand held remote & wall holder
- Built-In provision for optional 24V remote thermostat or Building Management System Integration.
- Compatible with NEST / any 24V WIFI stat
- Compatible with BMS systems
- Timer & Summer Fan Only Modes
- Compatible with optional wired window/door/occupancy sensors
- Auto Memory Feature: returns units to last settings after power outage
- 385 CFM output
- Adjustable louvers to direct air
- Built-In fan delay to dissipate heat
- Dual Pic-A-Watt® elements
- Patented Smart Limit® Protection
- Universal Wall/Ceiling bracket included
- Solid riveted construction for consistent, long-term durability
- Proudly Made in the USA with U.S. & Global Materials
- Optional ECO Pro controller available
- 5-Year limited warranty

## The KBP PlatinumX BMS Horizontal Unit Heater

King's KBP PlatinumX BMS series unit heaters are the most full-featured compact unit heaters on the market, with in-built electronic thermostat for accuracy and remote control for simple operation. Comes standard with a provision for adding an optional 24V thermostat, enabling remote temperature control with Nest and other WiFi thermostats, or seamless integration with a Building Management System (BMS). Includes integrated summer fan only and thermostat timer modes, the KBP PlatinumX has you covered. Designed for rugged performance, the flow-through design efficiently moves air by pulling air from the back of the heater and discharges it out the front, easily heating a large space. The integral fan delay continues to dissipate heat from the elements during the cool down period, maximizing the heat exchange in the room. King's exclusive dual Pic-A-Watt steel fin elements allow customers to select from a range of wattage options, tailoring the heater to an area's specific heating requirements.

Upgrade with the optional ECO PRO Controller, a remote wireless thermostat with a 7-day programmable schedule for personalized comfort or an optional wireless window/door and occupancy sensor to automatically reduce heat when windows are open or the room is unoccupied.

## PlatinumX BMS Electronic Controller Features

- Electronic control for accuracy
- Thermostat timer mode (1-9 Hours)
- Summer Fan only mode
- Large LED display
- Built-In fan delay
- Built-In provision for optional 24V remote thermostat
- Remote control and wall/ceiling bracket included
- Compatible with NEST / any 24V WIFI Stat
- Compatible with Building Management Systems (BMS)
- Compatible with Optional ECO PRO Controller
- Compatible with Optional Window/Door or Occupancy Sensors

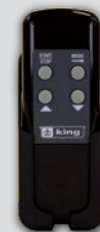

IR Remote



or Any 24V  
WIFI Stat



### Optional Controls



ECO Pro Controller



Occupancy Sensor



Window Sensor



# Compact Unit Heater KBP PlatinumX BMS Series

## Ordering Information - Electronic 1-Stage Thermostat

MODEL	UPC	WATTS	MAX BTUH (000)	PHASE	VOLTS	AMPS	CFM	TEMP. RISE	AIR THROW	MAX MOUNT HEIGHT	WT. (lbs.)
KBP2706-1-MB-PLTMX	70541	5700-4750-3800-2850-1900-950	19,454	1	277	14.5 - 3.6	385	33°F-8°F	12 ft.	8 ft.	26
KBP2005-3MP-MB-PLTMX	70542	5000-2900-2200	17,060	1-3**	208	15.8 - 7.9	385	41°F-23°F	12 ft.	8 ft.	26
KBP2406-3MP-MB-PLTMX	70543	5700-2850	19,454	1-3**	240/208*	13.7 - 6.9	385	47°F-8°F	12 ft.	8 ft.	26
KBP4806-3MP-MB-PLTMX	70544	5700-2850	19,454	1-3**	480	7.2	385	49°F	12 ft.	8 ft.	26

\*Approved for 208V operation. Heater will draw 13% less Amps and 25% less wattage \*\*3MP Prewired for 3-Phase, Field Convertable to 1-Phase

## Optional Field-Installed Disconnect Kit

MODEL	UPC	DESCRIPTION
KBP-HFD-KIT	70470	KBP Heat/Disconnect Switch, 120-277V, Field Installed Kit
KBP-480HFD-KIT	70551	KBP Heat/Disconnect Switch, 480V, Field Installed Kit

## Optional Field-Installed Control Accessories

MODEL	UPC	DESCRIPTION
ECO-PRO-CONTROLLER	70421	Pro Controller - 7-Day Programmable Thermostat/Remote Sensor/Remote
ECO-PRO-RF-PIR-SENSOR	70422	RF Battery Powered PIR Occupancy Sensor for ECO Models
ECO-PRO-RF-WINDOW-SENSOR	70423	RF Battery Powered PIR Window or Door Sensor for ECO Models

## TEMPERATURE RISE PER WATTAGE CHART

WATTS	BTUH	CFM	TEMP. RISE	WATTS	BTUH	CFM	TEMP. RISE
950	3,242	385	8	3800	12,969	385	31
1000	3,413	385	8	4000	13,652	385	33
1900	6,485	385	16	4160	14,198	385	34
2000	6,826	385	16	4750	16,212	385	39
2850	9,727	385	23	5700	19,454	385	47
3000	10,239	385	25	6000	20,478	385	49

# Compact Unit Heater KBP PlatinumX BMS Series

## Expand Your Control w/ Optional ECO PRO Controller & Wireless Sensors

*For 7-Day Programmable Heating Schedule & Automatic Temperature Setbacks*

### PLATINUMX



**BMS COMPATIBLE**

**Optional ECO Pro Controller**  
Programmable 7-Day Heating Schedule & Remote Temperature Sensor

**RF Occupancy Sensor (optional)**

**or**

**RF Window/Door Sensor (optional)**

**Room Unoccupied**  
Setback Options: 45°F, 55°F, 60°F or 65°

**Open Window or Door**  
Setback Options: 40°F, 45°F, 50°F or 55°

### Upgrade to the ECO PRO CONTROLLER: 7-Day Programmable Thermostat with Remote Temperature Sensing



Eco Pro Controller

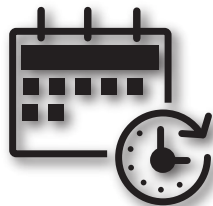

7-Day Programmable Heating Schedule



Balanced Heat Throughout the Space



Comfort, Right Where You Want It



Remote Temperature Sensing

# Compact Unit Heater KBP PlatinumX BMS Series

## Dimensional Data

Minimum clearance from combustibles: 18" from front, 2" from top, 6" from sides and 5" from rear.  
Minimum clearance 6" from floor. (Optional Disconnect Switch Shown)

# PLATINUMX

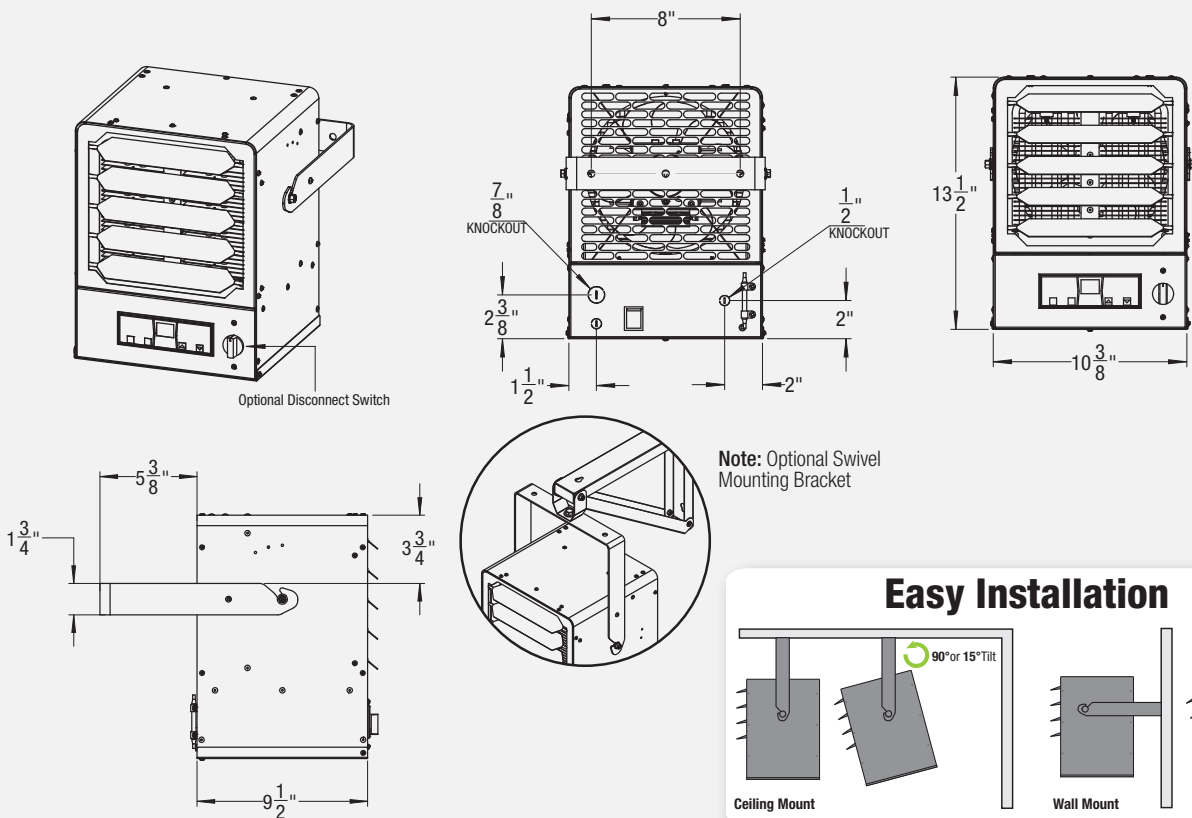

## Easy Installation

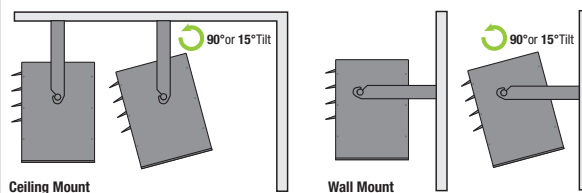

## Engineering Specifications

Contractor shall supply and install KBP PlatinumX BMS Series unit heaters manufactured by King Electrical Mfg. Company. Heaters shall be of the wattage and voltage as indicated on the plans.

**Construction:** All exterior and interior enclosure components are fabricated from 20-gauge electrogalvanized steel with a rust-inhibiting baked enamel finish. Components are assembled using solid mechanical rivets rather than spot welding, eliminating heat-affected zones and hidden weld defects. Riveted joints are fully visible and inspectable, providing consistent structural integrity under vibration and thermal cycling. Smooth rounded corners provide a clean, modern appearance.

**Pic-A-Watt Heating Elements:** Exclusive King multi-tap element allows field adjustment to several wattages at time of installation. Steel sheath elements of various resistance are copper brazed to steel plate fins producing a multi-wattage heating element.

**PlatinumX Electronic Control:** Thermostat Temperature Range: 40° to 95°. Up, Down temperature mode. Start/Stop. Fan Only and Timer (1-9hours) Modes. Standard on all heaters.

**Provision For 24V Remote Thermostat:** Includes terminals to connect an optional 24V Thermostat or BMS Systems. Compatible with NEST / any 24V WIFI Stat / 5-Wire BMS Systems.

**Auto Memory Feature:** Returns Unit To Last Settings After Power Outage. Provision For 24V Remote Thermostat: Includes terminals to connect an optional 24V Thermostat. Compatible with NEST / any 24V WIFI Stat.

**Adjustable Outlet Louver:** Louvers direct air up or down as needed for the heating application. **Rear Intake Screen:** Heavy gauge steel screen protects against foreign objects making accidental contact with the rotating fan blade.

**Rear Intake Screen:** Heavy gauge steel screen protects against foreign objects making accidental contact with the rotating fan blade.

**Unit Bearing Motor:** Permanently lubricated, long life, unit bearing 4-Pole motor with 20 cc of oil. Enclosed rotor provides long-lasting, trouble-free operation. Thermally protected. 1500 RPM.

**Aluminum Fan Blade:** 5 blade fan mounted directly to the motor shaft for maximum efficiency.

**CFM:** 385

**Universal Mounting Bracket:** Combination ceiling/wall bracket is included with every heater.

**Patented Smart Limit Protection (U.S. Patent #6,748,163 B2):** Equipped with King's patented thermal overload Smart Limit Protection®, which disconnects elements and motor in the event normal operating temperatures are exceeded. If thermal overload trips due to abnormal operating temperatures, thermal overload shall remain open until manually reset by turning the heater off for 15 minutes. Automatically reset of thermal overloads, which allow the element to continue to cycle under abnormal conditions, will not be accepted.

**Fan Delay Switch:** The fan continues to operate after the thermostat shuts off in order to remove the residual heat left in the elements. Power must not be interrupted.

**Standard Color:** Onyx Gray

**Easy Installation:** A hinged quick access panel located on the bottom of the heater allows for quick wiring and easy maintenance for the life of the heater. Includes universal wall/ceiling bracket for simple installation.

**Approval:** cULus (E41422)