

Kickspace Heater KT-MW Series



Model Code:

KT	12	10	-T
A	B	C	D
A: Series			
B: 12 - 120V 24 - 240V			
C: Watts (250 to 1500)			
D: Thermostat (optional)			



- Open coil nichrome elements
- C-Frame motor
- Squirrel cage blower
- Patented Smart Limit Protection*
- 20 gauge powder coated grill
- Dual wattage
- Standard color: white
- Optional almond, black, & stainless steel
- 120 or 240/208* volts
- Low profile
- 1-year limited warranty



The KT-MW Kickspace Heater

This narrow profile heater is only 3½" tall and specifically designed to conveniently fit under kitchen or bathroom cabinets, providing warm air for cold bathroom or kitchen. Valuable floor and wall space is saved. The optional KTG-24W Retrofit Grill allows for easy replacement of older kickspace heaters. Install heater and fit with long grill to cover existing cutout. For applications other than kickspace use KTG-OL Grill. Check floor covering manufacturer's recommendation for acceptable surface temperature.

Ordering Information *Add suffix -W for White Grill or -B for Black Grill

BASE MODEL	VOLTS	WATTS	AMPS	SHIP WEIGHT lbs
KT1215-MW	120	250•500•750•1000•1250•1500	2.1 - 12.5	8.5
KT2415-MW	240/208*	250•500•750•1000•1250•1500	1.0 - 6.3	8.5

*Dual rated heaters will draw 13% less amps and 25% less wattage when operated at 208V.

Factory Installed Options

ADD SUFFIX	DESCRIPTION	SHIP WEIGHT lbs
-B	Black Color	0
-W	White Color	0
-SS	Stainless Steel Color	0
-T	Onboard Single Pole Thermostat Kit	9
-T2	Onboard Double Pole Thermostat Kit	9
-HRC	Interior & Recessed Wall Can	7.5

NOTE: Not all configurations listed above are stock items (A+ or A stock code). Refer to price book for the Stock code. For non-stock items refer to the table below to order heater parts separately.

Order A'la Carte **To build your own "Complete" with designer grill options (not noted above) select HRC model of proper voltage and KTG grill model of proper color.

STEP 1: Order Heatbox Interior

ADD SUFFIX	UPC	DESCRIPTION	SHIP WEIGHT lbs
KT1215-MW-HRC	32714	KT Kick Space HTR 120V 1500W Interior & Recessed Wall Can	7.5
KT2415-MW-HRC	32718	KT Kick Space HTR 240/208V 1500W/1125W Interior and Recessed Wall Can	7.5

STEP 2: Order Grill

MODEL	UPC	DESCRIPTION	SHIP WEIGHT lbs
KTG-A	12296	Grill, Recessed - Almond - 3-1/2" x 16-1/2"	1.0
KTG-B	12297	Grill, Recessed - Black - 3-1/2" x 16-1/2"	1.0
KTG-W	12295	Grill, Recessed - White - 3-1/2" x 16-1/2"	1.0
KTG-SS-3-1/2	12267	Grill, Recessed - Stainless Steel Standard - 3-1/2" x 16-1/2" (No Overlap)	1.1
KTG-OL-B	12268	Grill, Surface Trim - Overlap 1/2" on All Sides - Black - 4-1/2" x 16-1/2"	1.1
KTG-OL-W	12275	Grill, Surface Trim - Overlap 1/2" on All Sides - White - 4-1/2" x 16-1/2"	1.1
KTG-SS	12269	Grill, Surface Trim - Overlap 1/2" on All Sides - Stainless Steel - 4-1/2" x 16-1/2"	1.1
KTG-24W-A	20533	Grill, Retrofit - Almond - 24" x 3-3/8"	1.0
KTG-24W-B	12299	Grill, Retrofit - Black - 24" x 3-3/8"	1.0
KTG-24W-W	12276	Grill, Retrofit - White - 24" x 3-3/8"	1.0

NOTE: This is the quickest option when the factory installed heaters options are not in stock.

Kickspace Heater KT-MW Series

Accessories

MODEL	UPC	DESCRIPTION	SHIP WEIGHT lbs
TKIT-1BW	20654	Built-in Single Pole Single Throw Thermostat Kit, Bright White	0.5
TKIT-2BW	20655	Built-in Double Pole Single Throw Thermostat Kit, Bright White	0.5
TKIT-1A	11058	Built-in Single Pole Single Throw Thermostat Kit, Almond	0.5
TKIT-2A	11059	Built-in Single Pole Single Throw Thermostat Kit, Almond	0.5
TKIT-1-TP	11056	Built-in Tamper Proof Single Pole Single Throw Thermostat Kit	0.4
TKIT-2-TP	11057	Built-in Tamper Proof Double Pole Single Throw Thermostat Kit	0.4
TKIT-1BL	17346	Wall Heater Accessory SP Thermostat Kit Black	0.5
TKIT-2BL	17347	Wall Heater Accessory DP Thermostat Kit Black	0.5
DS15	13824	Disconnect Switch, Field Installed Kit (10A/ 240V / 15A/120V)	0.5

Engineering Specifications

Contractor shall supply and install KT Series limited space-mounted forced air electric heaters manufactured by King Electrical Mfg. Company. Heaters shall be of the wattage and voltage as indicated on the plans.

Ratings: Heaters shall be available in wattages of 250 to 1,500 at 120 Volts or dual rated from 208 Volts to 240 Volts.

Blower and Motor: A tangential cylindrical blower, delivering 70 CFM, shall be driven by a shaded pole, permanently lubricated, C-frame type motor with impedance protection and sealed bearings. Motors shall be the same voltage as the heater.

Elements: Element assemblies shall be dual element construction of coiled Nickel Chromium alloy, corrosion resistant wire strung through a minimum of four rows of mica insulator. Element assemblies shall have factory provided connection to allow field modification to 50% wattage at time of installation.

Grill: The grill shall be a louvered, one-piece design. The grill shall be epoxy powder-coated in the color specified on the plans.

Thermal Overload: Heaters shall be equipped with King's patented thermal overload Smart Limit Protection®, which disconnects elements and motor in the event normal operating temperatures are exceeded. If thermal overload trips due to abnormal operating temperatures, thermal overload shall remain open until manually reset by turning the heater off for fifteen minutes. Automatic reset of thermal overloads, which allow the element to continue to cycle under abnormal conditions, will not be accepted.

Wall Can: The wall can shall be 20 gauge electrogalvanized steel and contain knockouts. The wall can shall be supplied with a factory installed ground wire. Zero Clearance to floors and 6" to sidewalls.

Approvals: cULus (E41422)

Dimensional Data

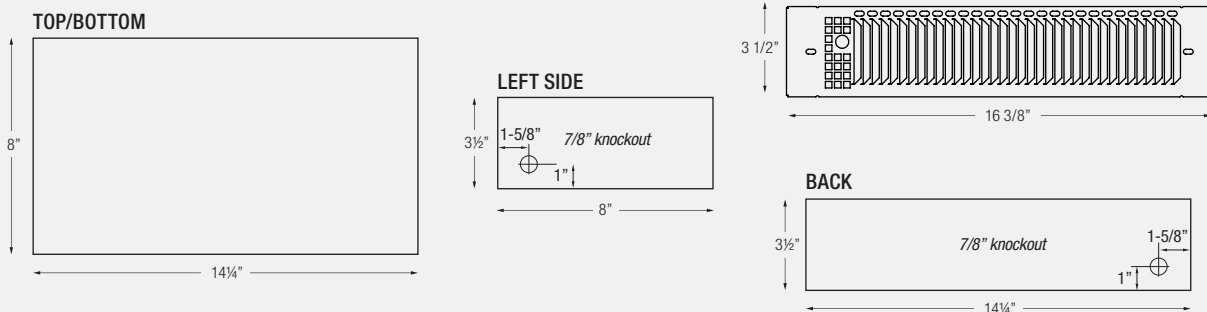

Installation

