

# NPR

New Product Release

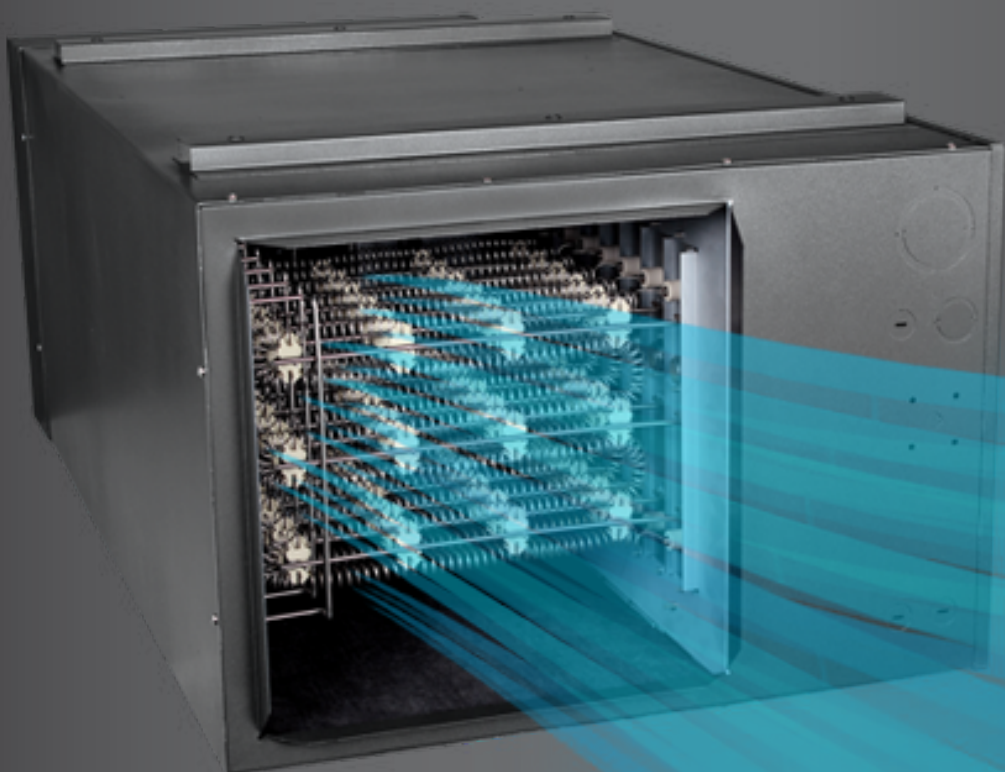

Shown with MAUFH Filter Housing (Sold Separately)

## CLEAR AIR MAU

Make Up Air Unit

700-1770 CFM @ 0.2"  
3.8kW to 34.5kW Models,  
1-3 Phase For Maximum  
Fresh Air In Residential,  
Commercial & Industrial  
Spaces.

All-in-one packaged unit featuring fully modulating electric heat with a fresh air control circuit. Fresh Air For Buildings. When You Need It.

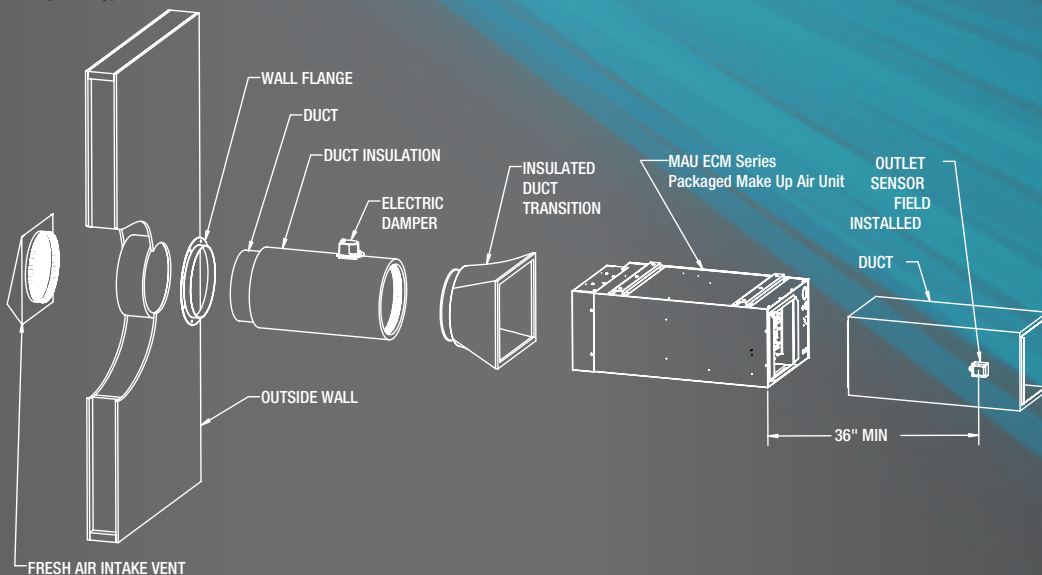

# CLEAR AIR MAU

## Make Up Air Unit

Packaged, All-In-One Make Up  
Air Solution

Proportional Thermostat For Fully  
Modulating Electric Heat

Wide Range of Air of CFM, Temperature  
Rise & Static Pressure Configurations

Energy Efficient ECM Motor with (5)  
Torque Taps

Available in 208/240V/480V -  
Single & Three Phase

Included Duct Sensor for Precise  
Set Points

Automatic Damper Control

Current Transformer Technology for Full  
Interlock with Exhaust Systems

Relay Logic Control Circuit Enabling  
Control of Other Make-Up Air  
Components (Damper, Exhaust Fans,  
Outside Thermostat & Humidistat, Etc).

Horizontal or Vertical Installation

Compact Footprint

Replaceable Air Filter (1" or 2" Thick)

Proudly Made in USA

### WARRANTY

3-Year Limited Warranty

# NPR

## New Product Release

## All-In-One Packaged Unit Featuring Fully Modulating Electric Heat with a Fresh Air Control Circuit.

## Fresh Air For Buildings. When You Need It.

Preheats Fresh Air For Comfort

Improves Indoor Air Quality



## Advanced Features for Ease of Use & Durability

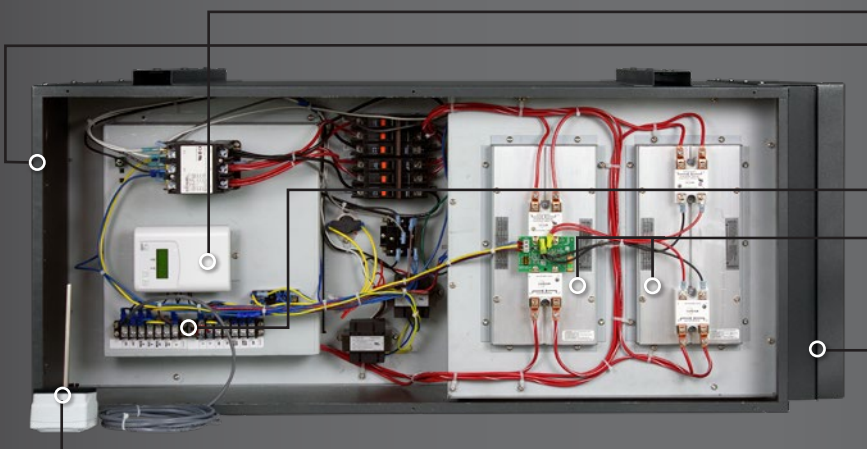

Proportional Thermostat For Fully Modulating Electric Heat

Wide Range of Air of CFM, Temperature Rise & Static  
Pressure Configurations

Included Duct Sensor For Precise Set Points

Automatic Damper Control

Relay Logic Control Circuit Enabling Control of Other Make Up  
Air Components (Damper, Exhaust Fans, Outside Thermostat  
& Humidistat, Etc).

Replaceable Air Filter (1" or 2" thick)

