

Programmable Thermostat WR/WRP

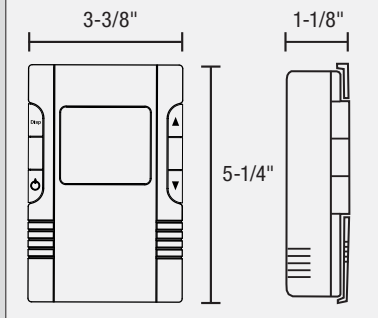

**LIMITED
2 Year
Warranty**

Dimensional Data



- **Models available:**
 - WR230: simple electronic thermostat
 - WRP230: adds 7 day programming
- **No models have No Delay on Setback**
- **Temperature range: 40° to 75°F (5° - 23°C)**
- **Power failure Restart: occupant's set point**
- **Display Format: Liquid Crystal Display (LCD)**
- **Remote-Controlled Set Back: yes (volt-free)**
- **Occupancy Sensing - 1 hour delay**
- **Window Activation: OFF (on display)**
- **40°F (5°C) set back when window is open**
- **60°F (15.5°C) Unoccupied temp**
- **Relay Rating: 16 Amps resistive or inductive**
- **Illumination: Seattle blue, on touch of key**
- **Heat Indicator: LCD- "Heater On"**
- **Sample Rate: 1 minute**
- **Accuracy: ±0.9°F/±0.5°C**
- **Max Watts: @ 208/240V = 3320/3840**
- **Minimum Watts: zero**
- **Power Supply: 208/240 Volts**
- **150 ft total loop distance**

The WR/WRP Series WINDOW WATCHER Thermostat

Residential housing projects, motels, and ski resorts often face unnecessarily high and very costly energy bills when windows and/or doors are left open for long periods of time, usually with the heating system on. Introducing the WINDOW WATCHER™ thermostat, designed to reinforce positive energy habits while limiting landlord energy expenses. With a maximum temperature of 74°/23°C the WINDOW WATCHER™ can be customized to your energy saving goals. Sensors placed in a window or door allow this smart thermostat to monitor when they are open. When the volt-free remote contacts are opened the WINDOW WATCHER™ will automatically set the thermostat back to 40°F/5°C, instantly saving you money! When the window or door is closed the thermostat will automatically return to the originally set comfort temperature. An optional occupancy sensor in line allows it to set the thermostat back when a room is unoccupied, potentially saving you even more. Motels can use contacts that are key card or key activated to begin room heating when the room is occupied, keep the heat to a minimum when unoccupied. Window open set back is clearly displayed on the large back-lit LCD screen when "OFF" appears. That is when you know money is staying in your pockets, not flying carelessly out the window! With no user hold or bypass possible, the WINDOW WATCHER™ is the perfect temperature control anywhere you can not monitor but need to. The WINDOW WATCHER™: real world, confirmed energy savings. Helping to save our resources and curb less desirable energy habits.

Ordering Information

MODEL	UPC	TYPE	DELAY ON SETBACK	WIRE LEADS	VOLTS	AMPS	TEMP. RANGE
WR120-B	19183	Non-Programmable Electronic	1 Minute	3 Wire	120	16	40°F/5°C-75°F/23°C
WRP120-B	19182	7-Day Programmable Electronic	1 Minute	3 Wire	120	16	40°F/5°C-75°F/23°C
WR230-B-ND	19095	Non-Programmable Electronic	NO	3 Wire	240/208	16	40°F/5°C-75°F/23°C
WRP230-B-ND	19091	7-Day Programmable Electronic	NO	3 Wire	240/208	16	40°F/5°C-75°F/23°C

Complete Kits

MODEL	UPC	DESCRIPTION	DELAY ON SETBACK	WIRE LEADS	VOLTS	AMPS	TEMP. RANGE
WR120-B-KIT	33511	Kit Includes Thermostat, Window Sensor and 50' Wire	1 Minute	3 Wire	120	16	40°F°-75°F°
WRP120-B-KIT	33512	Kit Includes Thermostat, Window Sensor and 50' Wire	1 Minute	3 Wire	120	16	40°F°-75°F°
WR230-B-KIT	33513	Kit Includes Thermostat, Window Sensor and 50' Wire	NO	3 Wire	240/208	16	40°F°-75°F°
WRP230-B-KIT	33514	Kit Includes Thermostat, Window Sensor and 50' Wire	NO	3 Wire	240/208	16	40°F°-75°F°

Accessories

MODEL	UPC	DESCRIPTION	COLOR	SHIP WEIGHT lbs
WR-COVER-BLANK	33508	Tamperproof Cover Plate, Blank, For WINDOW WATCHER Thermostat	WHITE	N/A
WINDOW-CONTACT	55543	Window Contact, Standard Surface / 507-AMS-39W	WHITE	N/A
50FT-BELL-WIRE	55544	50-FT Bell Wire, 18/2 RED/WHITE TWISTED	RED/WHITE	N/A

Programmable Thermostat WR/WRP

How It Works

Small bell-type wire, 90°C (22 gauge) connected to the back of this thermostat senses if a window or door is open. Simple magnetic switches used in alarm systems can be used as the contacts. Combined with occupancy sensors potential savings are maximized.

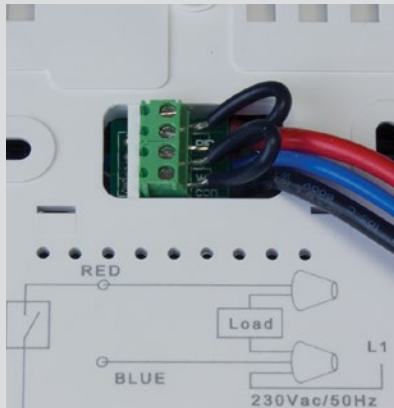

WINDOW WATCHER

