

Make Up Air Unit CLEAR AIR MAU Series



Model Code:

MAU	48	20	1	ECM	SSR
A	B	C	D	E	F

- A: Series
- B: 20 - 208V 24 - 240V
- C: Kilowatts
- D: 1 or 3-phase
- E: ECM Motor
- F: Solid State Relay



- Packaged, all-in-one make up air solution
- 700-1770 CFM @ 0.2" static pressure
- Plenum rated for concealed spaces
- Compact design, vertical or horizontal mounting
- Fully modulating electric heat using solid state relay (SSR) technology
- Built-in electronic proportional thermostat, 0-10V DC or 4-20ma
- Includes field installed remote duct sensor connected to thermostat
- Thermostat can be relocated to be used as a wall mounted room thermostat
- Energy efficient ECM motor, 1/3, 1/2HP & 3/4HP
- 5 motor torque settings for field adjustments to meet CFM and temperature rise requirements
- Detailed CFM/static pressure/temperature rise tables to design a perfect trouble-free solution
- Available in 208V, 240V and 480V – single or three phase
- 3.8KW to 34.5KW
- Integrated control circuit for connection to: damper, exhaust fans, outside thermostat & humidistat, ect. (accessories purchased seperately)
- Includes lockout circuit for BMS compatability
- Separate 40VA control power transformer for auxiliary devices
- Side access panel for easy wiring & maintenance
- 20-gauge electro galvanized steel cabinet with corrosion resistant textured paint finish
- Includes 1" replaceable filter (compatible w /2")
- 3-year limited warranty

The King Clear Air Make-Up Air Unit is a plenum rated unit, designed to “make up” the air in your interior space that has been removed due to process exhaust fans. The building ventilation and the make-up air system work together to ensure the building pressure is maintained, while eliminating temperature fluctuations and a number of air quality issues. Clear Air MAU preheats the incoming fresh air at the lowest cost, thus continuously providing comfortable ventilation throughout the building. Featuring an energy efficient ECM motor, the Clear Air combines a fan driven fully modulating electric heating unit with a fresh air relay logic control circuit providing an extremely versatile all-in-one packaged unit. The MAU is approved for use in concealed areas of buildings such as an area between a finished ceiling and drop ceiling. It is designed to work with HVAC equipment to provide indoor air quality into a return side or supply side of the ductwork system or alternatively directly into the building space.

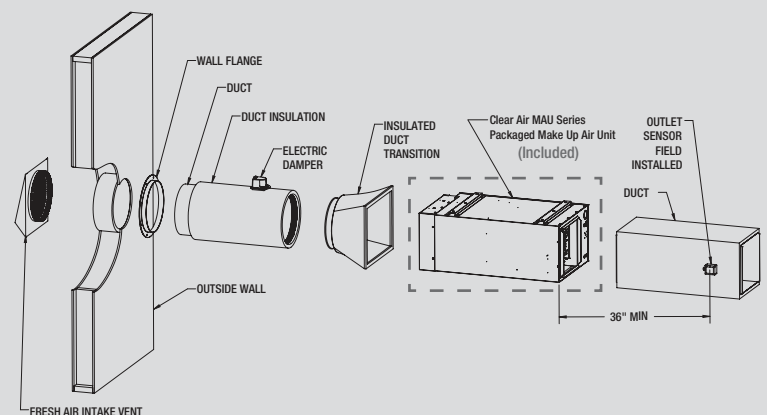

The King Clear Air MAU includes the Packaged Make Up Air Unit and Duct Sensor. Other components are common and are purchased separately by the installer.

Make Up Air Unit CLEAR AIR MAU Series

Ordering Information

	MODEL	VOLTS	kilo watts	BTUH	AMPS	PHASE	# of ELEMENTS	INTERNAL C/B	MOTOR HP	MOTOR FLA	WT. (lbs)
208V 1-Phase	MAU2004-1-ECM-SSR	208	3.8	12.8	18	1	1	60	1/3	2.7	57
	MAU2005-1-ECM-SSR	208	5.0	17.1	24	1	1	60	1/3	2.7	57
	MAU2008-1-ECM-SSR	208	8.0	27.3	38	1	2	60	1/3	2.7	57
	MAU2010-1-ECM-SSR	208	10.0	34.1	48	1	2	60+60	1/3	2.7	65
	MAU2012-1-ECM-SSR	208	12.0	41.0	58	1	3	60+60	1/3	2.7	74
	MAU2015-1-ECM-SSR	208	15.0	51.2	72	1	3	60+60	1/3	2.7	74
	MAU2018-1-ECM-SSR	208	17.3	58.9	83	1	4	60+60	1/3	3.9	76
	MAU2020-1-ECM-SSR	208	20.0	68.3	96	1	4	60+60	1/2	3.9	76
	MAU2025-1-ECM-SSR	208	25.0	85.3	120	1	5	60+60+60	1/2	6.0	81
	MAU2030-1-ECM-SSR	208	30.0	102.4	144	1	6	60+60+60	3/4	6.0	85
240V 1-Phase	MAU2404-1-ECM-SSR	240	4.0	13.7	17	1	1	60	1/3	2.9	57
	MAU2405-1-ECM-SSR	240	5.0	17.1	21	1	1	60	1/3	2.9	57
	MAU2408-1-ECM-SSR	240	8.0	27.3	33	1	2	60	1/3	2.9	57
	MAU2410-1-ECM-SSR	240	10.0	34.1	42	1	2	60	1/3	2.9	65
	MAU2412-1-ECM-SSR	240	12	41.0	50	1	2	60	1/3	2.9	74
	MAU2415-1-ECM-SSR	240	15.0	51.2	63	1	3	60+60	1/3	2.7	74
	MAU2418-1-ECM-SSR	240	17.3	58.9	72	1	3	60+60	1/3	2.7	74
	MAU2420-1-ECM-SSR	240	20.0	68.3	83	1	4	60+60	1/2	4.2	76
	MAU2425-1-ECM-SSR	240	25.0	85.3	104	1	5	60+60+60	1/2	4.2	81
	MAU2430-1-ECM-SSR	240	30.0	102.4	125	1	6	60+60+60	3/4	6.2	85
480V 1-Phase	MAU2435-1-ECM-SSR	240	34.5	117.8	144	1	6	60+60+60	3/4	6.2	85
	MAU4804-1-ECM-SSR	480	4.0	13.7	8	1	1	NO	1/3	0.7	57
	MAU4805-1-ECM-SSR	480	5.0	17.1	10	1	1	NO	1/3	0.7	57
	MAU4808-1-ECM-SSR	480	8.0	27.3	17	1	2	NO	1/3	0.7	57
	MAU4810-1-ECM-SSR	480	10.0	34.1	21	1	2	NO	1/3	0.7	65
	MAU4812-1-ECM-SSR	480	12.0	41.0	25	1	3	NO	1/3	0.7	74
	MAU4815-1-ECM-SSR	480	15.0	51.2	31	1	3	NO	1/3	0.7	74
	MAU4818-1-ECM-SSR	480	17.3	58.9	36	1	3	NO	1/3	0.7	74
	MAU4820-1-ECM-SSR	480	20.0	68.3	42	1	4	NO	1/2	1.1	76
	MAU4825-1-ECM-SSR	480	25.0	85.3	52	1	5	NO	1/2	1.1	81
208V 3-Phase	MAU4830-1-ECM-SSR	480	30.0	102.4	63	1	6	NO	3/4	1.1	85
	MAU4835-1-ECM-SSR	480	34.5	117.7	72	1	6	NO	3/4	1.1	85
	MAU2005-3-ECM-SSR	208	5.0	17.1	14	3	1	60	1/3	2.7	57
	MAU2007-3-ECM-SSR	208	7.5	25.6	21	3	2	60	1/3	2.7	57
	MAU2010-3-ECM-SSR	208	10.0	34.1	28	3	2	60	1/3	2.7	65
	MAU2012-3-ECM-SSR	208	12	42.7	34	3	3	60	1/3	2.7	65
	MAU2015-3-ECM-SSR	208	15.0	51.2	42	3	3	60	1/3	2.7	74
	MAU2020-3-ECM-SSR	208	20.0	68.3	56	3	4	60	1/2	3.9	76
	MAU2025-3-ECM-SSR	208	25.0	85.3	69	3	5	60+60	3/4	6.0	81
	MAU2030-3-ECM-SSR	208	30.0	102.4	83	3	6	60+60	3/4	6.0	85
240V 3-Phase	MAU2405-3-ECM-SSR	240	5.0	17.1	12	3	1	60	1/3	2.9	57
	MAU2410-3-ECM-SSR	240	10.0	34.1	24	3	2	60	1/3	2.9	65
	MAU2412-3-ECM-SSR	240	12.0	41	29	3	3	60	1/3	2.9	74
	MAU2415-3-ECM-SSR	240	15.0	51.2	36	3	3	60	1/3	2.9	74
	MAU2418-3-ECM-SSR	240	17.3	58.9	42	3	3	60	1/3	2.9	74
	MAU2420-3-ECM-SSR	240	20.0	68.3	48	3	4	60	1/2	4.2	76
	MAU2425-3-ECM-SSR	240	25.0	85.3	60	3	5	60	1/2	4.2	81
	MAU2430-3-ECM-SSR	240	30.0	102.4	72	3	6	60+60	3/4	6.2	85
	MAU2435-3-ECM-SSR	240	34.5	117.7	83	3	6	60+60	3/4	6.2	85
	480V 3-Phase	MAU4805-3-ECM-SSR	480	5.0	17.1	6	3	1	NO	1/3	0.8
MAU4810-3-ECM-SSR		480	10.0	34.1	12	3	2	NO	1/3	0.8	65
MAU4815-3-ECM-SSR		480	15.0	51.2	18	3	3	NO	1/3	0.8	74
MAU4818-3-ECM-SSR		480	17.3	58.9	21	3	3	NO	1/3	0.8	74

Make Up Air Unit CLEAR AIR MAU Series

Ordering Information

MODEL	VOLTS	kilo watts	BTUH	AMPS	PHASE	# of ELEMENTS	INTERNAL C/B	MOTOR HP	MOTOR FLA	WT. (lbs)
MAU4820-3-ECM-SSR	480	20.0	68.3	24	3	4	NO	1/2	1.2	76
MAU4825-3-ECM-SSR	480	25.0	85.3	30	3	5	NO	1/2	1.2	81
MAU4830-3-ECM-SSR	480	30.0	102.4	36	3	6	NO	3/4	1.7	85
MAU4835-3-ECM-SSR	480	34.5	117.7	42	3	6	NO	3/4	1.7	85

*Includes motor load

Accessories

MODEL	UPC	DESCRIPTION	WEIGHT(lbs.)
KFS-DT	20186	Transition from 14" x 14" Outlet to 12" round, discharge side	2.5

Motor Options

MODEL	DESCRIPTION
-1/2 HP	4kW to 17.25kW
-3/4 HP	4kW to 25kW

Controls Accessories

MODEL	UPC	DESCRIPTION	WEIGHT(lbs.)
DFC120V	33445	Digital Fan Control, 5 Modes of Operation - 120V (Requires -CR120 Factory Installed Option)	1.0

Factory Installed Options

ADD SUFFIX:	DESCRIPTION
-CR120	10 Amp Relay, SPDT w/10-30 Vac/dc/120 Vac Coil that switches the 24V heater control circuit
-DS32	32 Amp, 3-Pole Disconnect Switch w/ Padlock Provision
-DS63	63 Amp, 3-Pole Disconnect Switch w/ Padlock Provision
-DS100	100 Amp, 3-Pole Disconnect Switch w/ Padlock Provision

Direct Ducting Installation

The Clear Air MAU can be installed to have its own dedicated outdoor fresh air duct system that is filtered, pre-heated and then is distributed DIRECTLY to each room and hallway through register grills. In this way, it acts independently to the primary heating system that could be hydronic, electric zonal heat or a centralized HVAC system. When installed as a direct system, make sure the Temperature rise is sufficient to bring adequate warm tempered air into the building. For example, in a cold climate when the outside air is at 0°F the Temperature rise would need to be at least 70°F to warm the air adequately before delivering it directly to the occupied space.

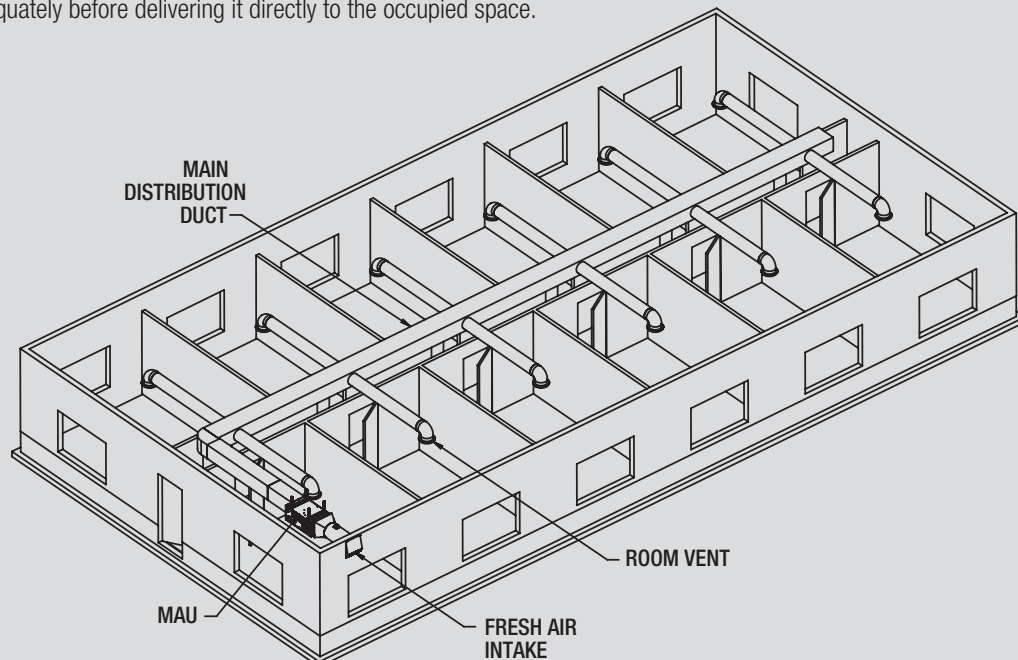

Make Up Air Unit CLEAR AIR MAU Series

HVAC Return and Supply Air Ducting Connection

The second method consists of using the furnace distribution system to distribute fresh air. There are two methods of connecting the device to the furnace: Supply air side connection or Return air side connection.

RETURN AIR SIDE SYSTEM

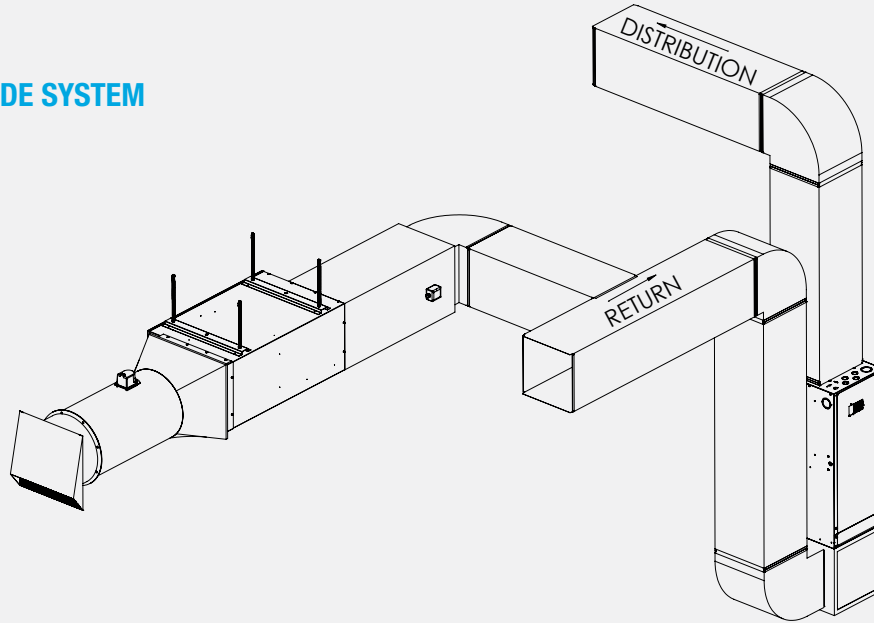

Return Connection: Cut an opening in the return air duct at least 3 feet from the furnace. Connect this opening to the Clear Air MAU.

DISTRIBUTION AIR SIDE SYSTEM

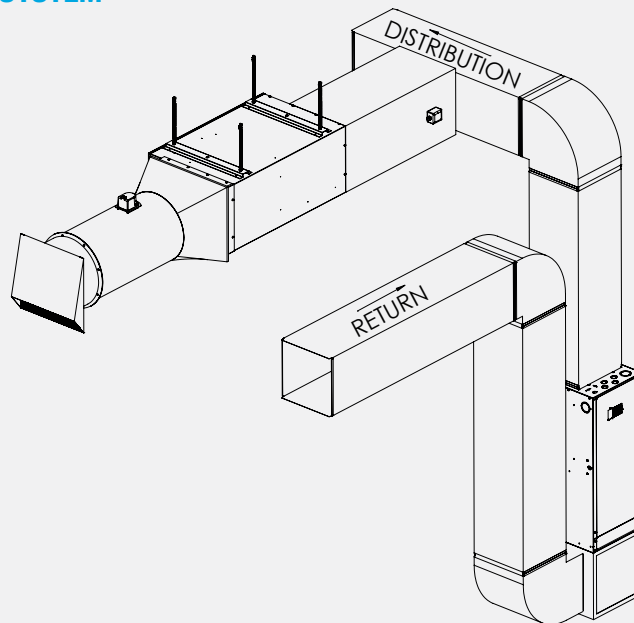

Supply Connection: Cut an opening in the supply air duct, at least 2 ft. from the furnace. Connect this opening to the Clear Air MAU.

Make Up Air Unit CLEAR AIR MAU Series

Air Flow Chart (For 4 to 17.25kW Units with 1/3HP ECM Motor)

MODEL	KW	TORQUE	0.1"WC		0.2"WC		0.3"WC		0.4"WC		0.5"WC		0.6"WC		0.7"WC		0.8"WC		0.9"WC		1.0"WC			
			CFM	RISE	CFM	RISE	CFM	RISE	CFM	RISE	CFM	RISE	CFM	RISE	CFM	RISE	CFM	RISE	CFM	RISE	CFM	RISE	CFM	RISE
				(F)		(F)		(F)		(F)		(F)		(F)		(F)		(F)		(F)		(F)		(F)
MAU**04	4	6.8	832	15	708	18	593	21	510	25	442	29	374	34	320	39	278	46						
		9.4	1,030	12	919	14	826	15	739	17	658	19	594	21	546	23	494	26						
		12.0	1,168	11	1,085	12	992	13	902	14	835	15	783	16	736	17	700	18						
		17.0	1,376	9	1,320	10	1,259	10	1,189	11	1,116	11	1,060	12	1,016	12	987	13						
		20.0	1,582	8	1,536	8	1,462	9	1,380	9	1,275	10	1,192	11	1,107	11	1,043	12						
MAU**05	5	6.8	832	19	708	22	593	27	510	31	442	36	374	42	320	49	278	57						
		9.4	1,030	15	919	17	826	19	739	21	658	24	594	27	546	29	494	32						
		12.0	1,168	14	1,085	15	992	16	902	18	835	19	783	20	736	21	700	23						
		17.0	1,376	11	1,320	12	1,259	13	1,189	13	1,116	14	1,060	15	1,016	16	987	16						
		20.0	1,582	10	1,536	10	1,462	11	1,380	11	1,275	12	1,192	13	1,107	14	1,043	15						
MAU**08	8	6.8	832	30	708	36	593	43	510	50	442	57	374	68	320	79	278	91						
		9.4	1,030	25	919	27	826	31	739	34	658	38	594	43	546	46	494	51						
		12.0	1,168	22	1,085	23	992	25	902	28	835	30	783	32	736	34	700	36						
		17.0	1,376	18	1,320	19	1,259	20	1,189	21	1,116	23	1,060	24	1,016	25	987	26						
		20.0	1,582	16	1,536	16	1,462	17	1,380	18	1,275	20	1,192	21	1,107	23	1,043	24						
MAU**10	10	6.8	832	38	708	45	593	53	510	62	442	71	374	84	320	99	278	NR						
		9.4	1,030	31	919	34	826	38	739	43	658	48	594	53	546	58	494	64						
		12.0	1,168	27	1,085	29	992	32	902	35	835	38	783	40	736	43	700	45						
		17.0	1,376	23	1,320	24	1,259	25	1,189	27	1,116	28	1,060	30	1,016	31	987	32						
		20.0	1,582	20	1,536	21	1,462	22	1,380	23	1,275	25	1,192	27	1,107	29	1,043	30						
MAU**12	12	6.8	832	46	708	54	593	64	510	74	442	86	374	101	320	NR	278	NR						
		9.4	1,030	37	919	41	826	46	739	51	658	58	594	64	546	69	494	77						
		12.0	1,168	32	1,085	35	992	38	902	42	835	45	783	48	736	52	700	54						
		17.0	1,376	28	1,320	29	1,259	30	1,189	32	1,116	34	1,060	36	1,016	37	987	38						
		20.0	1,582	24	1,536	25	1,462	26	1,380	27	1,275	30	1,192	32	1,107	34	1,043	36						
MAU**15	15	6.8	832	57	708	67	593	80	510	93	442	107	374	NR	320	NR	278	NR						
		9.4	1,030	46	919	52	826	57	739	64	658	72	594	80	546	87	494	96						
		12.0	1,168	41	1,085	44	992	48	902	53	835	57	783	61	736	64	700	68						
		17.0	1,376	34	1,320	36	1,259	38	1,189	40	1,116	42	1,060	45	1,016	47	987	48						
		20.0	1,582	30	1,536	31	1,462	32	1,380	34	1,275	37	1,192	40	1,107	43	1,043	45						
MAU**18	17.25	6.8	832	66	708	77	593	92	510	107	442	NR	374	NR	320	NR	278	NR						
		9.4	1,030	53	919	59	826	66	739	74	658	83	594	92	546	100	494	110						
		12.0	1,168	47	1,085	50	992	55	902	60	835	65	783	70	736	74	700	78						
		17.0	1,376	40	1,320	41	1,259	43	1,189	46	1,116	49	1,060	51	1,016	54	987	55						
		20.0	1,582	34	1,536	35	1,462	37	1,380	40	1,275	43	1,192	46	1,107	49	1,043	52						

Air Flow Chart (For 20 to 25kW Units with 1/2HP ECM Motor)

MODEL	KW	TORQUE	0.1"WC		0.2"WC		0.3"WC		0.4"WC		0.5"WC		0.6"WC		0.7"WC		0.8"WC		0.9"WC		1.0"WC			
			CFM	RISE	CFM	RISE	CFM	RISE	CFM	RISE	CFM	RISE	CFM	RISE	CFM	RISE	CFM	RISE	CFM	RISE	CFM	RISE	CFM	RISE
				(F)		(F)		(F)		(F)		(F)		(F)		(F)		(F)		(F)		(F)		(F)
MAU**20	20	15.5			1,258	50	1,262	50	1,193	53	1,132	56	1,054	60	910	69	834	76	821	77	705	90		
		19.0			1,466	43	1,419	45	1,300	49	1,285	49	1,218	52	1,180	54	1,015	62	979	65	934	68		
		22.5			1,575	40	1,570	40	1,564	40	1,363	46	1,347	47	1,284	49	1,256	50	1,200	53	1,152	55		
		26.0			1,690	37	1,679	38	1,640	39	1,546	41	1,472	43	1,430	44	1,378	46	1,358	47	1,315	48		
		30.0			1,771	36	1,766	36	1,723	37	1,728	37	1,569	40	1,542	41	1,522	42	1,487	43	1,415	45		
MAU**25	25	15.5			1,258	63	1,262	63	1,193	66	1,132	70	1,054	75	910	87	834	95	821	96	705	NR		
		19.0			1,466	54	1,419	56	1,300	61	1,285	61	1,218	65	1,180	67	1,015	78	979	81	934	85		
		22.5			1,575	50	1,570	50	1,564	51	1,363	58	1,347	59	1,284	62	1,256	63	1,200	66	1,152	69		
		26.0			1,690	47	1,679	47	1,640	48	1,546	51	1,472	54	1,430	55	1,378	57	1,358	58	1,315	60		
		30.0			1,771	45	1,766	45	1,723	46	1,728	46	1,569	50	1,542	51	1,522	52	1,487	53	1,415	56		

A ** Represents the voltage, 20=208V, 24=240V, 48=480V. Voltage of the MAU unit does not affect the data in this table.

B NR= Not Recommended, Temperature Rise is above maximum design parameter.

C The highlighted cells are the factory default torque setting for each model. The ECM motor has 5 field adjustable torque settings, allowing for a wide range of design choices.

E Blower: 10" diameter, 8" wide

Make Up Air Unit CLEAR AIR MAU Series

Air Flow Chart (For 20 to 25kW Units with OPTIONAL 3/4HP ECM Motor)

MODEL	KW	0.1"WC		0.2"WC		0.3"WC		0.4"WC		0.5"WC		0.6"WC		0.7"WC		0.8"WC		0.9"WC		1.0"WC		
		TORQUE	CFM	RISE	CFM	RISE	CFM	RISE	CFM	RISE	CFM	RISE	CFM	RISE	CFM	RISE	CFM	RISE	CFM	RISE	CFM	RISE
MAU**20	20			(F)																		
		26.0			1,592	40	1,592	40	1,581	40	1,551	41	1,529	41	1,496	42	1,432	44	1,353	47	1,231	51
		30.0			1,789	35	1,758	36	1,716	37	1,650	38	1,598	40	1,552	41	1,451	41	1,451	44	1,282	49
		35.0			1,814	35	1,819	35	1,828	35	1,866	34	1,849	34	1,794	35	1,688	37	1,561	40	1,316	48
		40.5			2,080	30	2,122	30	2,082	30	2,054	31	1,916	33	1,814	35	1,700	37	1,482	43	1,230	51
MAU**25	25	45.0			2,174	29	2,154	29	2,148	29	2,138	30	2,094	30	1,928	33	1,671	38	1,471	43	1,232	51
		26.0			1,592	50	1,592	50	1,581	50	1,551	51	1,529	52	1,496	53	1,432	55	1,353	58	1,231	NR
		30.0			1,789	44	1,758	45	1,716	46	1,692	47	1,650	48	1,598	49	1,552	51	1,451	54	1,282	62
		35.0			1,814	44	1,819	43	1,828	43	1,866	42	1,849	43	1,794	44	1,688	47	1,561	51	1,316	60
		40.5			2,080	38	2,122	37	2,082	38	2,054	38	1,916	41	1,814	44	1,700	46	1,482	53	1,230	64
			2,174	36	2,154	37	2,139	37	2,138	37	2,094	38	1,928	41	1,671	47	1,471	54	1,232	64		

Air Flow Chart (For 30 to 35kW Units with 3/4HP ECM Motor)

MODEL	KW	0.1"WC		0.2"WC		0.3"WC		0.4"WC		0.5"WC		0.6"WC		0.7"WC		0.8"WC		0.9"WC		1.0"WC		
		TORQUE	CFM	RISE	CFM	RISE	CFM	RISE	CFM	RISE	CFM	RISE	CFM	RISE	CFM	RISE	CFM	RISE	CFM	RISE	CFM	RISE
MAU**30	30			(F)																		
		26.0			1,592	60	1,592	60	1,581	60	1,551	61	1,529	62	1,496	63	1,432	NR	1,353	NR	1,231	NR
		30.0			1,789	53	1,758	54	1,716	55	1,692	56	1,650	57	1,598	59	1,552	61	1,451	65	1,282	74
		35.0			1,814	52	1,819	52	1,828	52	1,866	51	1,849	51	1,794	53	1,688	56	1,561	61	1,316	72
		40.5			2,080	46	2,122	45	2,082	46	2,054	46	1,916	49	1,814	52	1,700	56	1,482	64	1,230	77
MAU**35	35	45.0			2,174	44	2,154	44	2,148	44	2,138	44	2,094	45	1,928	49	1,671	57	1,471	64	1,232	77
		26.0			1,592	69	1,592	69	1,581	60	1,551	71	1,529	72	1,496	NR	1,432	NR	1,353	NR	1,231	NR
		30.0			1,789	62	1,758	63	1,716	64	1,692	65	1,650	67	1,598	69	1,552	71	1,451	NR	1,282	NR
		35.0			1,814	61	1,819	61	1,828	60	1,866	59	1,849	60	1,794	62	1,688	66	1,561	71	1,316	84
		40.5			2,080	53	2,122	52	2,082	53	2,054	54	1,916	58	1,814	61	1,700	65	1,482	75	1,230	90
			2,174	51	2,154	51	2,148	52	2,138	52	2,094	53	1,928	57	1,671	66	1,471	75	1,232	90		

A ** Represents the voltage, 20=208V, 24=240V, 48=480V. Voltage of the MAU unit does not affect the data in this table.
 B NR= Not Recommended, Temperature Rise is above maximum design parameter.
 C The highlighted cells are the factory default torque setting for each model. The ECM motor has 5 field adjustable torque settings, allowing for a wide range of design choices.
 E Blower: 10" diameter, 8" wide

Airflow Design Considerations

The King Clear Air MAU has a wide range of airflow options that can be field adjusted to match the needs of a specific installation. Providing fresh air into a building has several design parameters that must be taken into consideration:

1. The amount of fresh air required is normally calculated as Cubic Feet per Minute (CFM) per person or CFM per square feet of the building or a room. The required CFM can also be designed to meet a specific exhaust air condition such as in a commercial kitchen where the MAU is set to match the exhaust air of the cooking hoods.
2. Static pressure is one of the most important factors in HVAC design. Simply put, static pressure refers to the resistance to airflow in a heating and cooling system's components and duct work. To determine operating total external static pressure, measure pressures where air enters and leaves the MAU equipment. Add the two readings together to find total external static pressure. Make sure not to exceed the external static pressures listed in the design tables, doing so will cause harm the equipment.
3. Temperature rise or Delta T is the difference between the incoming air temperature and the discharge temperature of the MAU. In make-up air applications the required temperature rise is influenced by the geographic territory where colder climates require much more heat capacity to temper cold incoming air into the building. Another factor to consider is whether the fresh air is delivered directly such as to a room, hallway or delivered to the supply side of an HVAC system where the conditioned air might need to be 70F versus the fresh air being delivered to the return air intake where the design temperature could be 55F. Under sizing the MAU could lead to insufficient delivery temperatures causing colder than desired air to enter the building.

Make Up Air Unit CLEAR AIR MAU Series

Dimensional Data

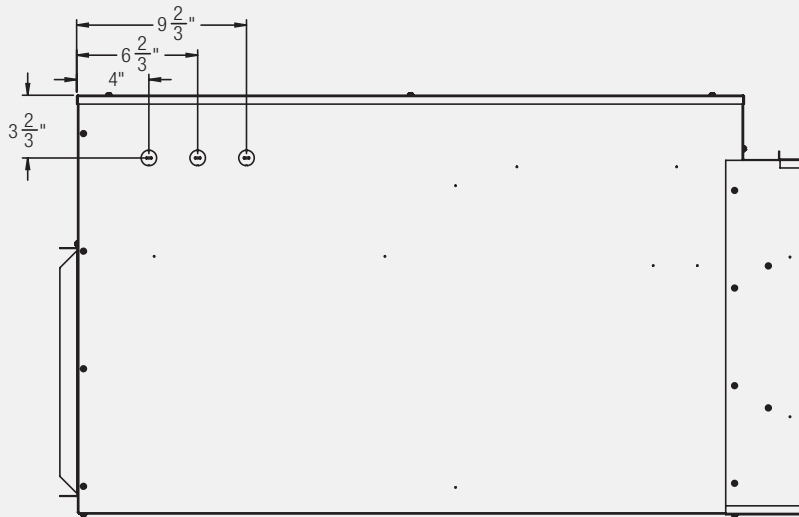

BOTTOM



LEFT

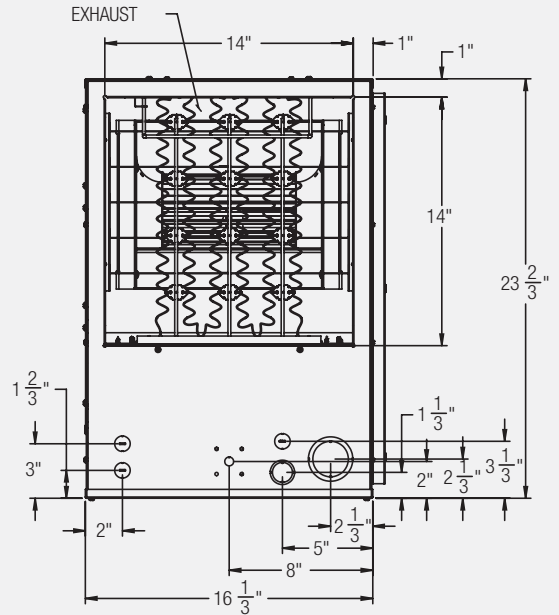

FRONT

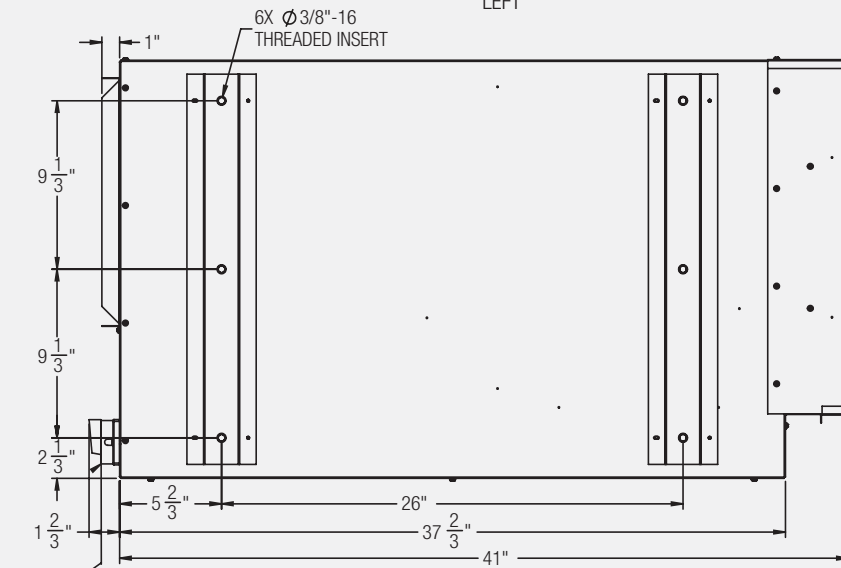

TOP

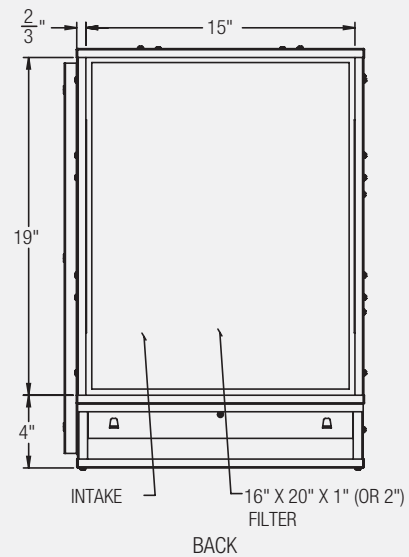

BACK

OPTIONAL DISCONNECT SWITCH

Make Up Air Unit CLEAR AIR MAU Series

Horizontal/Vertical Mounting Illustration

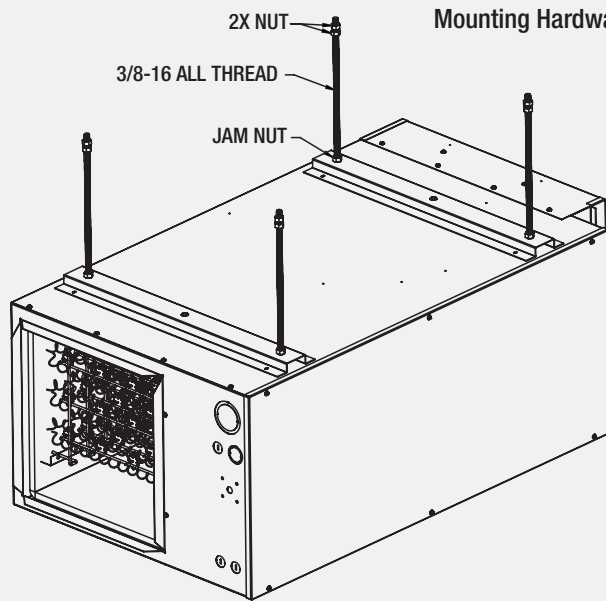

Horizontal

Mounting Hardware Not Included

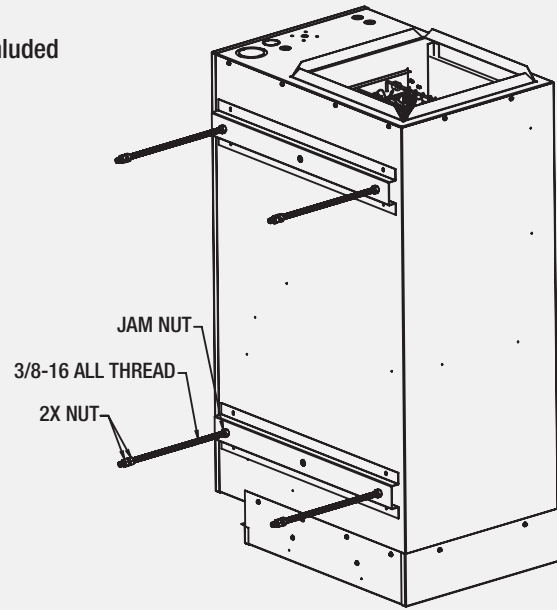

Vertical

Motor Torque Field Adjustment

The versatility of the King Clear Air MAU allows for the ECM motor torque to be adjusted in the field. Pressure test the system to find the actual external static pressure, then fine tune the system by adjusting the motor torque setting. The goal is to meet the CFM/Temperature rise combination for the intended design criteria. The ECM motor is pre-programmed with 5 torque values and terminated at the 5-point terminal strip as shown below.

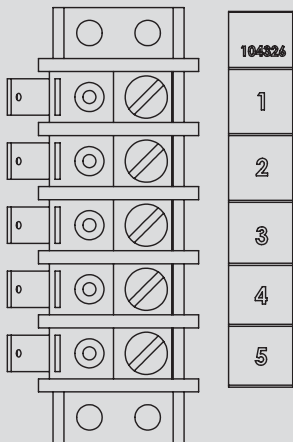

Motor Tap#	1/3 HP Torque	1/2 HP Torque	3/4 HP Torque	Wire Color
1	6.8 in-lb.	15.5 in-lb.	26.0 in-lb.	RED
2	9.4 in-lb.	19.0 in-lb.	30.0 in-lb.	ORANGE
3	12.0 in-lb.	22.5 in-lb.	35.0 in-lb.	BLACK
4	17.0 in-lb.	26.0 in-lb.	40.5 in-lb.	ORANGE/BLACK
5	20.0 in-lb.	30.0 in-lb.	45.0 in-lb.	BROWN/BLACK



ECM Motor

Make Up Air Unit CLEAR AIR MAU Series

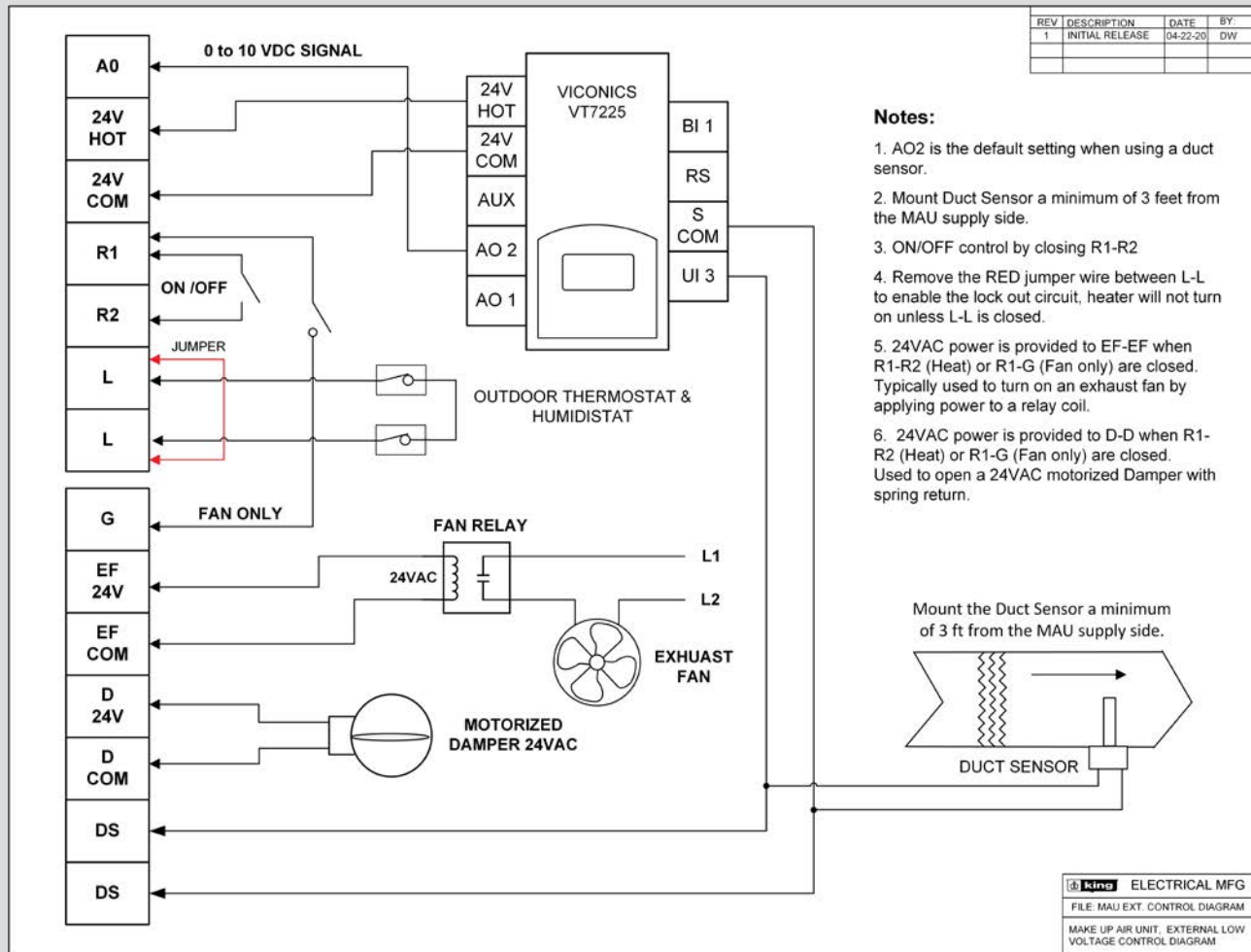

Low Voltage Control Wiring

The King Clear Air MAU has a built-in relay logic control circuit enabling other make up air components to be controlled directly by the MAU. Review all the system components such as the damper, exhaust fans, outside thermostat and humidistat. All the control options are prewired to a 14-point terminal strip making them easy to integrate by the installer. The control circuit does not require any programming, simply enabled the control features by wiring the external components directly to the MAU low voltage terminal strip. List of control features:

- R1-R2, ON/OFF control of the MAU. Closing this circuit via a dry contact will turn on the fan and the modulating heating circuit. This is often done by a building management system, but other common methods are to be activated by a current transformer (CT) on an exhaust fan, a timer, or a manual switch. Once on, the Solid-State Relay (SSR) regulates the wattage to the heating elements to accurately control the discharge air temperature from the MAU regardless of the incoming outdoor air temperature.
- A0, proportional signal from the built-in thermostat (0-10VDC) that drives the SSR to modulate the heat output.
- DS-DS, DUCT SENSOR, the field installed duct sensor is connected to thermostat for controlling and maintaining the output temperature, type 2 NTC thermistor, 10K ohms.
- 24V HOT - 24V COM, these are the 24VAC connections to the modulating thermostat.
- L-L, LOCKOUT CIRCUIT, the controller can be wired to an optional outdoor thermostat and/or a humidistat by using the 'L-L' terminals to prevent the MUA from turning on. Remove the factory set jumper to activate this feature. This feature can also be used to monitor indoor activity such as an occupancy sensor and CO2 sensor.
- G, FAN ONLY, closing G-R1 will turn on the fan and bypass the modulating heating circuit. No heat in this mode.
- EF-EF, EXHAUST FAN, provides a switched 24VAC circuit to connect a fan relay that will turn on an exhaust fan relay or other auxiliary device.
- D-D, DAMPER, provides a switched 24VAC circuit to connect to a motorized damper with spring return. Note: 40VA maximum for the sum of EF-EF and D-D.

Note: If the design calls for a room thermostat, the inbuilt thermostat and duct sensor can be removed. Place the thermostat in the new room location and extend the wiring connections from the MAU low voltage terminal strip, connect A0 on the terminal strip to AO 2 on the thermostat when used as a room thermostat without a duct sensor.

Make Up Air Unit CLEAR AIR MAU Series

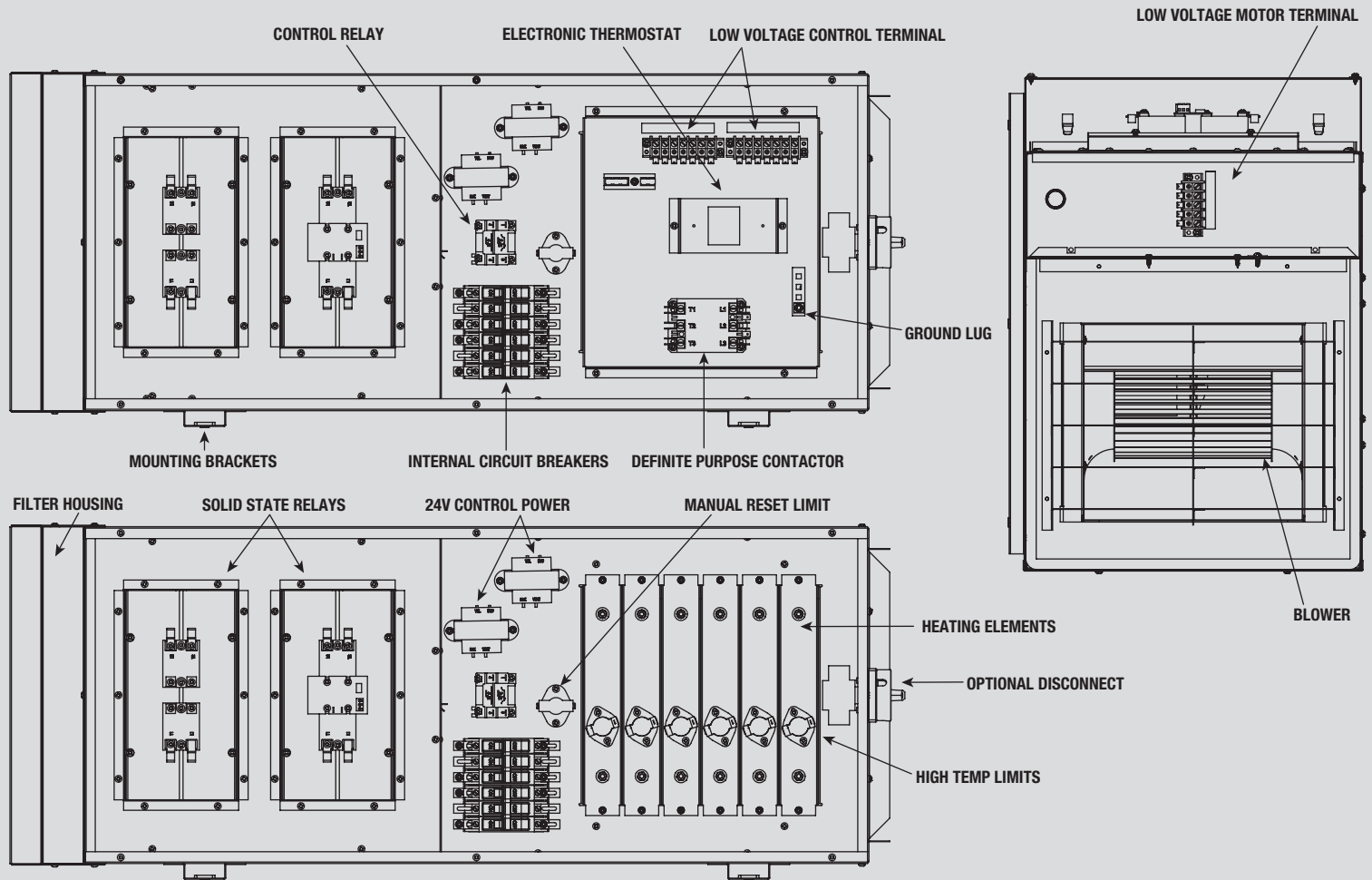

Engineering Specifications

Contractor shall furnish and install King Make up air unit (MAU) manufactured by King Electrical Manufacturing.

Motor: Direct drive high efficiency, thermally protected, permanently lubricated ECM motor, no belts to adjust or maintain.

Motor Terminal: The MAU shall have a 5-point terminal block to easily field adjust the motor torque setting of the ECM motor.

Modulating Heat: 100% fully modulating heating control through Solid State Relay (SSR) technology. The SSR relays shall be mounted in the blower compartment to allow the free flow of incoming air to cool the heat sinks.

Thermostat: The MAU shall be controlled by an electronic proportional thermostat using a 0 to 10VDC of 4 to 20ma signal. The inbuilt thermostat can be removed and relocated to room and used as a wall mounted thermostat.

Duct Sensor: The MAU shall be provided with a field installed duct sensor, type 2 NTC thermistor, 10K ohms.

Heating Elements: Quick heating, long life Ni-Chrome elements supported by a steel frame and insulated with ceramic holders.

LV Terminal Block: All low voltage wires are terminated at a 14-point block with factory side quick connects and field side screw terminals.

Control Circuit: The MAU shall have a relay logic control circuit providing a dedicated 24V power supply that is switched to activate external devices such as: a damper, exhaust fan, etc..

Lockout Circuit: The MAU shall have a lockout circuit for auxiliary devices such as an outside thermostat or humidistat to prevent the MUA from turning on unless predetermined conditions are met & BMS compatibility

Overcurrent Protection: The MAU shall have a 24V high temperature limit circuit wired in series to protect each individual heating element. In addition, it shall have one electrically held manual limit monitoring the condition of entire unit. If tripped, this limit must be manually reset by shutting off the power, waiting several minutes and then turning the power back on. This provides an extra level of overheating protection to the unit.

Enclosure: The MAU shall be constructed from 20GA electrogalvanized sheet metal of welded construction and finished with a corrosion resistant gray finished. Unpainted sheet steel is not acceptable. Access to the wiring compartment shall be from the side for easy wiring and maintenance. The unit shall have welded brackets with 6 - 3/8" weld nuts for sturdy mounting either vertically or horizontally. Provide both Line voltage and Low voltage knockouts to speed contractor installation. Provide knockouts for an optional disconnect.

Filter: Includes filter housing with 1" thick replaceable air filter. Compatible w/2" filter (Purchased Separately)

Blower: Centrifugal dual inlet blower shall be used, axial fans not permitted. Blower shall be rigidly mounted to the enclosure with internal welded mounting brackets.

Optional Disconnect: The unit shall have the option to mount an internal Supply Power Disconnect.

Approvals: UL: The MAU shall be Underwriters Laboratory (UL) approved and labeled. Meets UL1995 standards and stringent City of Chicago codes for plenum use.