



# PYROBOX3/19

# PYROBOX3C/19

# PYROBOX5/19

## Installation and Operating manual



## Index

---

<b>Introduction</b> .....	<b>4</b>
<b>PYROBOX Installation notes</b> .....	<b>5</b>
Wiring the PYROBOX3/19.....	6
Wiring the PYROBOX3C/19.....	7
Wiring the PYROBOX5/19.....	8
<b>Connecting snow sensors and PYROBOX/19 slaves</b> .....	<b>9</b>
Installation and Wiring Connections – PYROSENSE.....	10
Installation and Wiring Connections – PYROSENSE-GUTTER.....	11
Installation and Wiring Connections – PYROSENSE-GROUND.....	12
<b>Operating instructions</b> .....	<b>13</b>
Green power lamp.....	13
RED GOUND FAULT RESET lamp and button.....	13
Turning the syste, ON and OFF.....	13
Selecting temperature scale.....	13
Selecting Automatic or Manual mode .....	13
Heaters indication.....	13
Snow flake icon and digital time indication.....	13
<b>Technician settings</b> .....	<b>14</b>
Enter technician settings mode.....	14
P01 - Temperature set point.....	15
P02 - Lower limit temperature for heating .....	16
P03 – Upper limit temperature for heating.....	16
P04 -Time delay before stopping the heaters.....	17
P05 - Manual mode ON time.....	17
P06 – Heaters cycle and splitting time.....	18
P07 - Heater outputs logic by PYRO sensors or by 3 <sup>rd</sup> party sensor .....	19
P08 - Snow sensor sensitivity .....	20
P88 - Snow detection threshold.....	20
P09 - Number of snow sensors connected.....	21
P10 - Test conditions mode .....	22
P11 – Master/Slave.....	23
P12 - Controller’s MAC Address .....	23
P13 – Not in use .....	24
P14 – Reset PYRO sensors MAC Address.....	25
P15 – Offset for calibration of measures temperature.....	24
Save changes and return to normal display.....	24
<b>Restore default values</b> .....	<b>24</b>

## Index

---

<b>DIP Switch settings</b> .....	<b>25</b>
DIP switch S2 - Short measuring times (test only) .....	25
DIP switches S3 and S4 – heaters sequencing logic.....	25
<b>Enable/Disable zones</b> .....	<b>26</b>
<b>Select critical zones</b> .....	<b>27</b>
<b>BMS communication protocol – BACnet/Modbus (DIP switch S6)</b> .....	<b>28</b>
<b>Temperature reading errors</b> .....	<b>28</b>
Ambient temperature sensor readings out of range.....	28
Communication error with one or more snow sensors.....	28
Upper limit temperature sensor is not connected or short circuit .....	28
<b>Object list - Modbus</b> .....	<b>29</b>
<b>Object list - BACnet</b> .....	<b>30</b>
<b>Appendix 1 - Calibrating and testing the internal GFEP</b> .....	<b>31</b>

## Introduction

The PYROBOX3/3C/5/19/19 power boxes together with the PYROCON12/19 controller and interface panel, offer smart and easy control over the PYRO Snow & Ice Melting system.

It can operate up to 4 snow melting zones and one auxiliary zone, with selectable sequencing method. Typical applications include driveways, sidewalks, loading docks, stairs, pavements and gutters.

The backlit LCD screen provides full interface and information of the system status.

The use of several zones staggering allow covering larger area for snow melting with a limited available electrical power.

The PYROBOX/19 offers various operating and programming options such as:

- Switchable temperature scales (°F or °C)
- Both Automatic and Manual modes
- Adjustable heaters cycle and splitting times
- Adjustable heaters hold on off delay
- Optional auxiliary control based 3<sup>rd</sup> party snow sensor (e.g. Gutter/Pavement sensor)
- Adjustable Lower ambient temperature limit to stop heaters (lockout)
- Energy saving temperature limit
- Adjustable snow sensor sensitivity
- Commissioning/Test environment
- Master/Slave connections

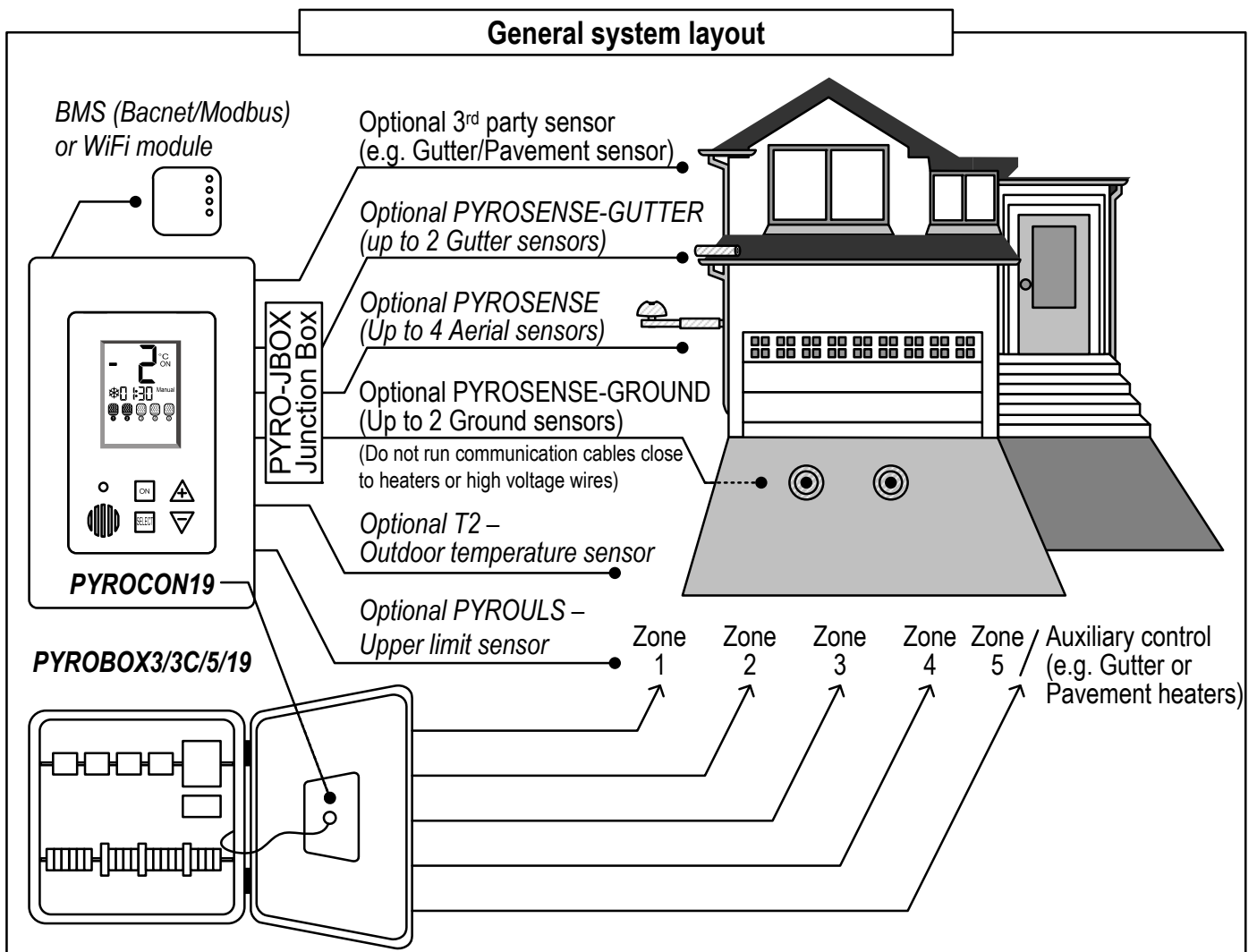

## **PYROBOX Series Installation**

**PLEASE READ THIS MANUAL AND THE SAFETY WARNINGS CAREFULLY BEFORE INSTALLING AND USING THE CONTROLLER AND SAVE IT FOR FUTURE USE**

### **Installation notes**

- Familiarize yourself with the markings, warnings, components and terminology.
- The PYROBOX power boxes and its accessories must be installed by a qualified electrician in accordance with local regulations and the requirements of the NEC (NFPA 72 ) and the CEC part 1.
- **WARNING:** Ensure the power is disconnect from all circuits before mounting the power box and making any connections. Contact with components carrying hazardous voltage can cause electric shock and may result in severe personal injury or death.
- **Installer must ensure the installation of approved disconnect means, for all power supply circuits feeding this unit.**
- The power boxes are suitable for indoor wall mount installation only.
- Ensure wiring according to the provided schematics using copper conductors only.
- Make sure the wire gauge (AWG) is suitable for the circuit amperage draw, as specified in the NEC/CEC table 1.
- Ensure that the main breakers (fuses) are suitable for the heating systems rating (80% load).
- Grounding means must comply with local regulations and CEC/NEC.
- Ensure that the heating system/de-icing system connected to this unit complies with the UL 499 or UL 515 & CSA 22.2 # 130.3 standard and is certified / listed by an NRTL.
- Ensure that all wiring is rated for the application at 60°C (140°F as per UL 515 CSA 22.2 #130 clause 12 table 12.1.
- Ensure that any holes punched for conduit are to compromise the integrity of the enclosure ratings.

### **Ground fault circuit interrupter (GFEP)**

- The ground fault interrupter/residual current detector installed in this system is a Non class A GFEP, intended for equipment protection.
- Familiar yourself with its operation and required setting.
- At installation and commissioning stage use a calibrated milliamp meter to read and record the heating systems natural leakage.

Set the GFI/RCD to no more than 30 milliamps higher than that reading.

- This step might have to be repeated a few times, to avoid nuisance tripping.
- The GFEP should be tested monthly. Please refer to the calibration and testing instructions in appendix 1 of this manual.

# Wiring the PYROBOX3/19

**⚠ Caution:** Incorrect voltage may cause fire or seriously damage the unit.  
 Make sure the wire gauge (AWG) is suitable for the circuit Amperage draw, as specified in the NEC/CEC table 1.

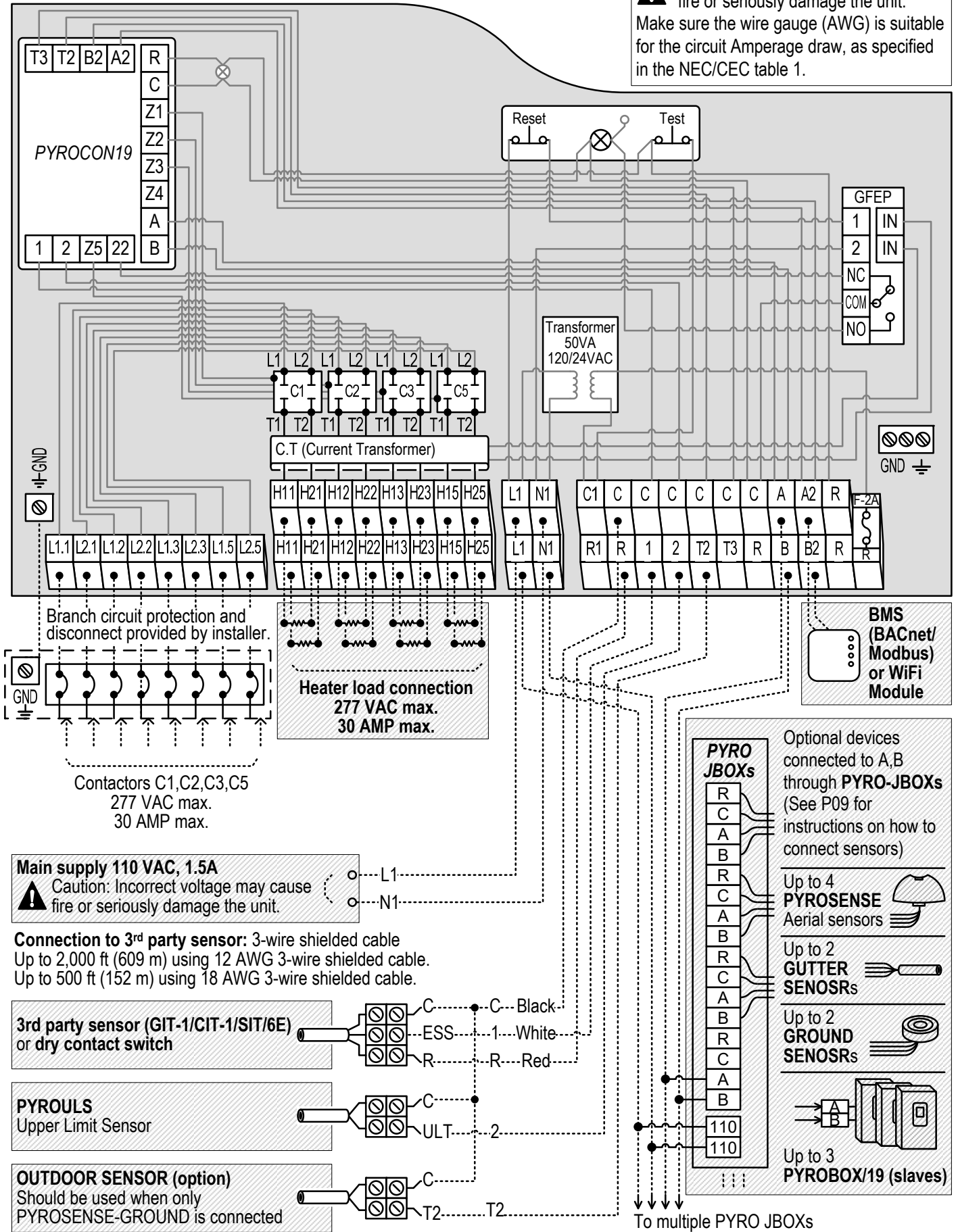

**Main supply 110 VAC, 1.5A**  
 ⚠ Caution: Incorrect voltage may cause fire or seriously damage the unit.

**Connection to 3<sup>rd</sup> party sensor:** 3-wire shielded cable  
 Up to 2,000 ft (609 m) using 12 AWG 3-wire shielded cable.  
 Up to 500 ft (152 m) using 18 AWG 3-wire shielded cable.



**BMS (BACnet/Modbus) or WiFi Module**

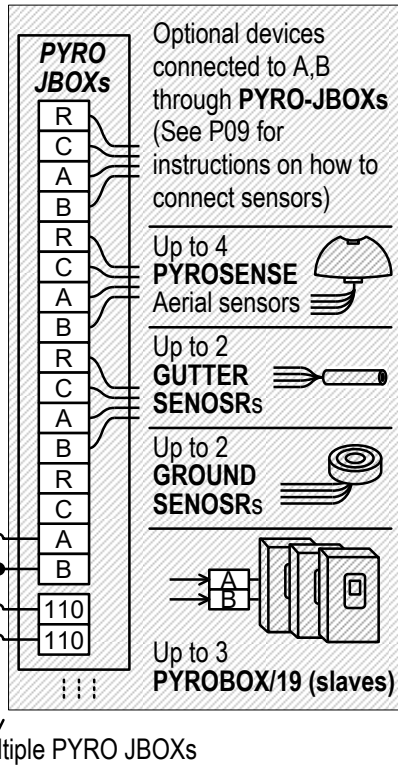

# Wiring the PYROBOX3C/19

**⚠ Caution:** Incorrect voltage may cause fire or seriously damage the unit.  
Make sure the wire gauge (AWG) is suitable for the circuit Amperage draw, as specified in the NEC/CEC table 1.

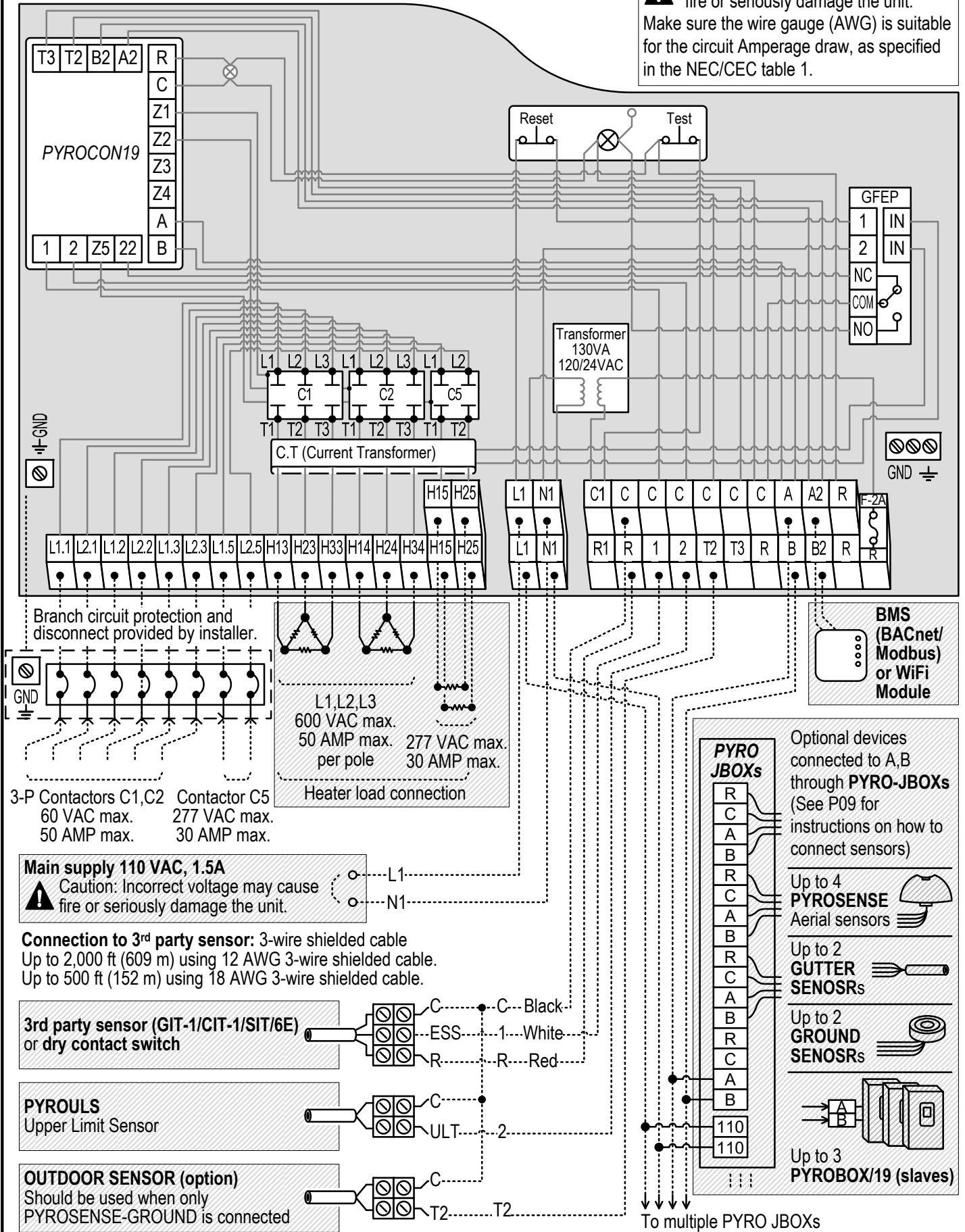

**Main supply 110 VAC, 1.5A**  
**⚠ Caution:** Incorrect voltage may cause fire or seriously damage the unit.

**Connection to 3<sup>rd</sup> party sensor:** 3-wire shielded cable  
 Up to 2,000 ft (609 m) using 12 AWG 3-wire shielded cable.  
 Up to 500 ft (152 m) using 18 AWG 3-wire shielded cable.

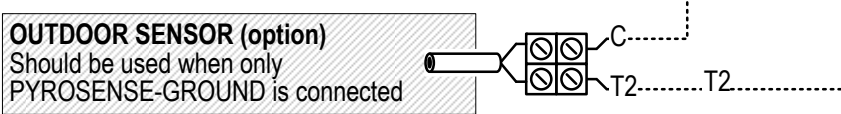
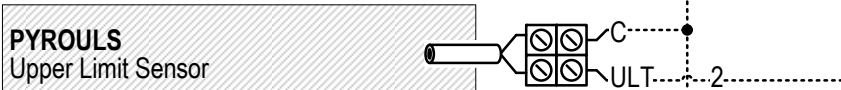

# Wiring the PYROBOX5/19

**Caution:** Incorrect voltage may cause fire or seriously damage the unit.  
Make sure the wire gauge (AWG) is suitable for the circuit Amperage draw, as specified in the NEC/CEC table 1.

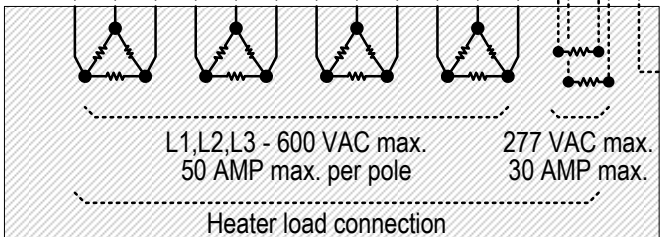
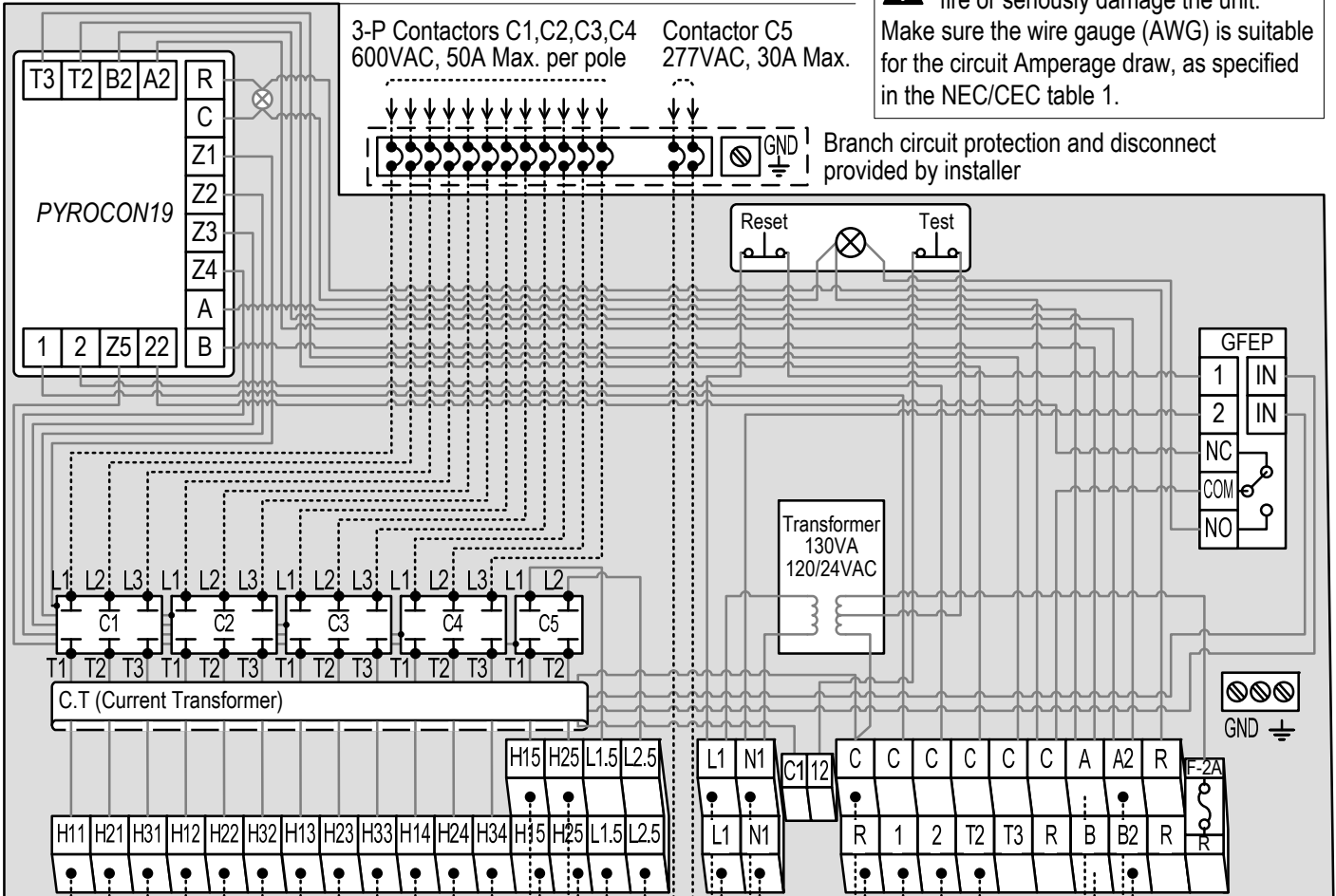

**Main supply 110 VAC, 1.5A**  
**Caution:** Incorrect voltage may cause fire or seriously damage the unit.

**Connection to 3rd party sensor:** 3-wire shielded cable  
 Up to 2,000 ft (609 m) using 12 AWG 3-wire shielded cable.  
 Up to 500 ft (152 m) using 18 AWG 3-wire shielded cable.

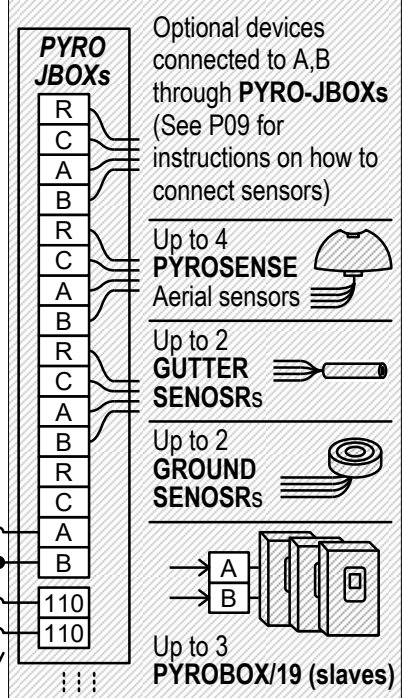
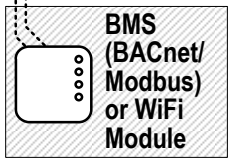
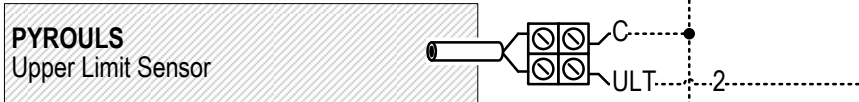
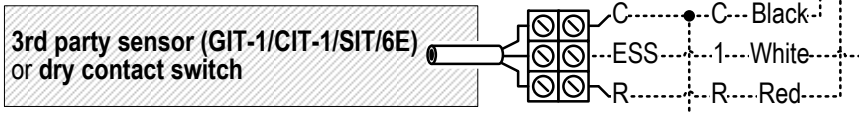



## Connecting communicating sensors and PYROBOX/19 slaves

Device/Sensor type	Number of sensors/devices	Power consumption (24VAC)	Power/Comm. cable length	MAC Address
PYROSENSE Aerial sensor	Up to 4	4VA	32.8ft / 10m	1-4
Ground sensors	Up to 2	15.6VA	32.8ft / 10m	5-6
Gutter sensor	Up to 2	4VA	32.8ft / 10m	7-8
PYROBOX/19 (slaves)	Up to 3	x	x	14-16

These devices/sensors can be connected directly to A,B terminals on the PYROBOX/19 or through multiple PYRO-JBOX junction boxes with built in 50VA, 110~24VAC transformer - Allowing connection and powering up to 3 sensors.

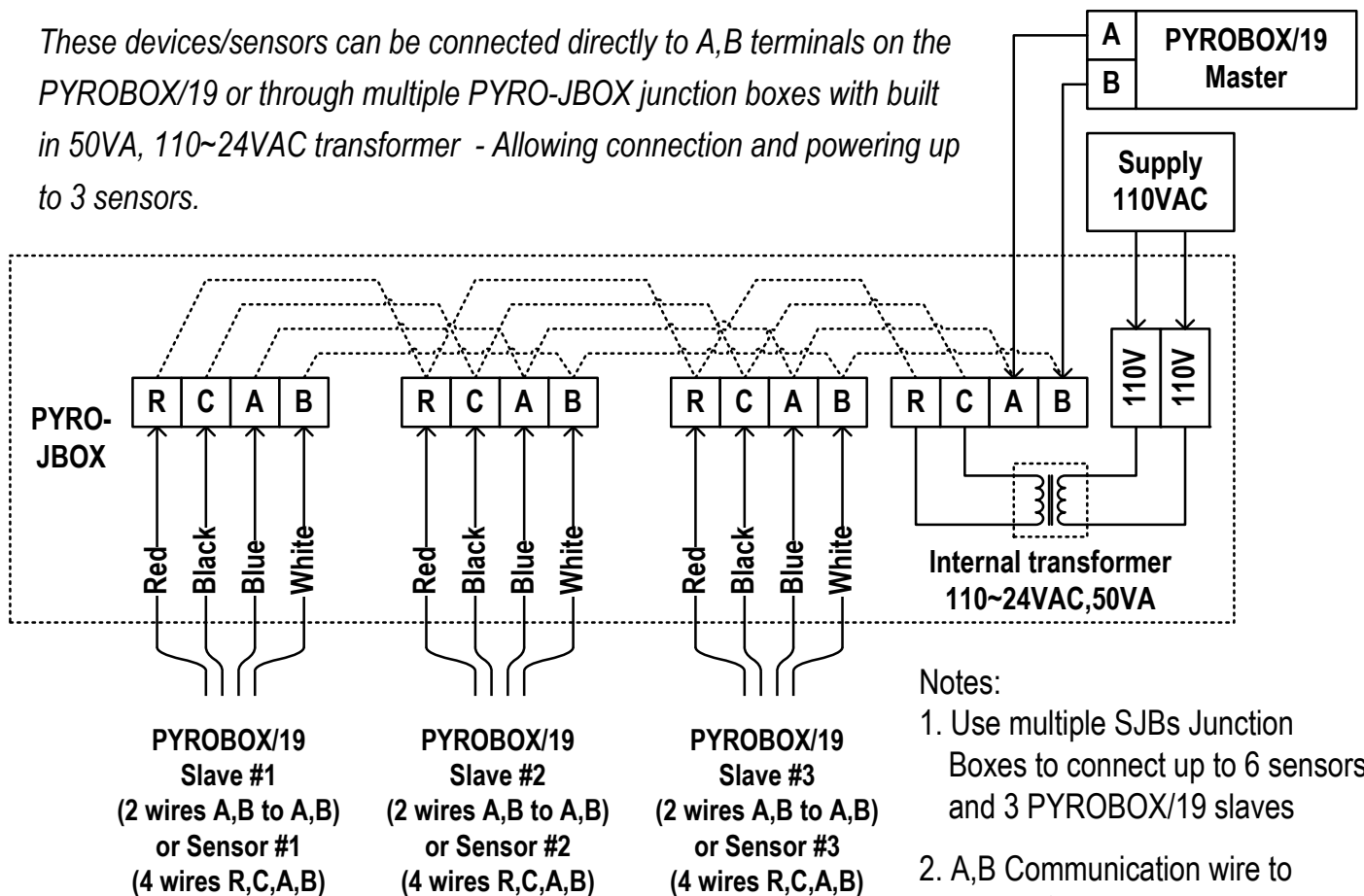

### Notes:

1. Use multiple SJBs Junction Boxes to connect up to 6 sensors and 3 PYROBOX/19 slaves
2. A,B Communication wire to slaves: flexible twisted pair overall foil + braid shielded and overall jacketed with a flexible PVC compound, 2000 ft, (600 m) maximum length.

## Installation and Wiring Connections – PYROSENSE

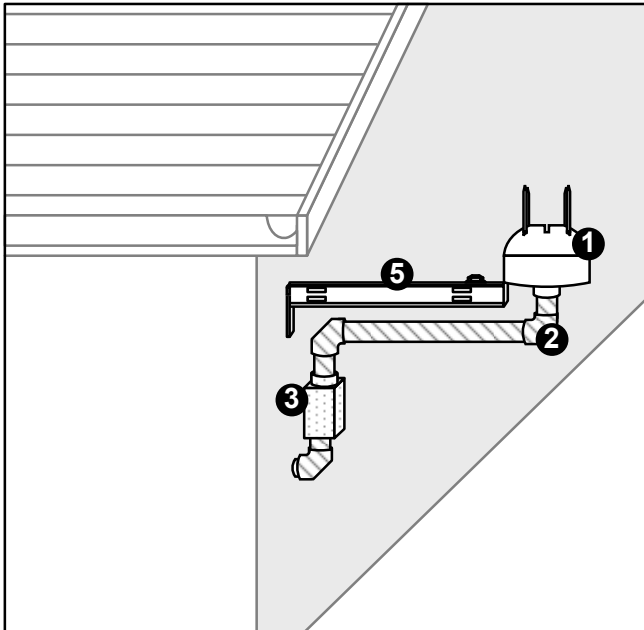

Wall mount installation

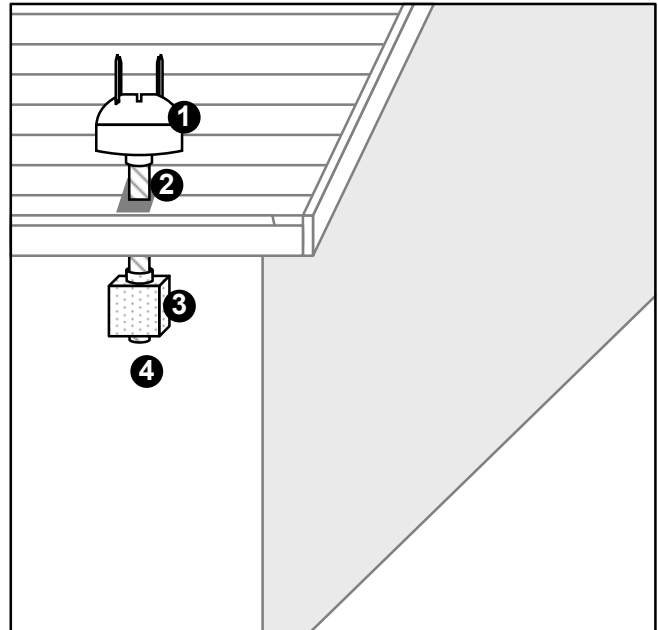

Roof installation

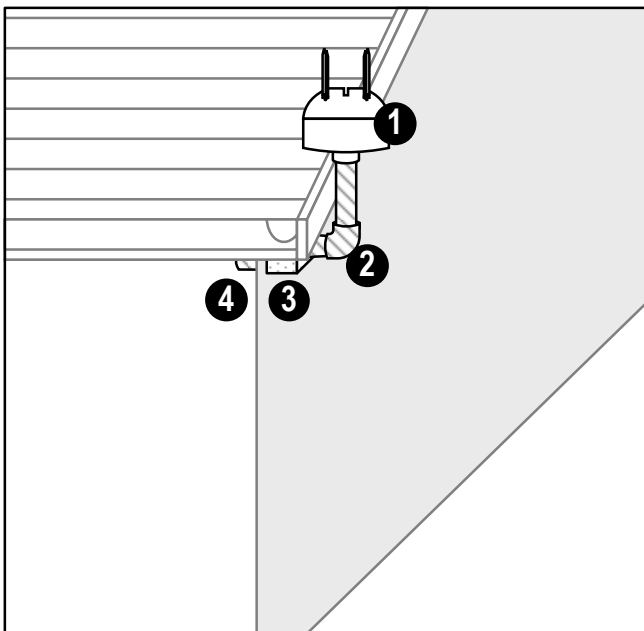

Roof side installation

- ❶ PYROSENSE
- ❷ Waterproof conduit (Supplied by installer).  
Use non-metallic, UL listed, flexible conduit 3/4".  
Maximal length between the PYROSENSE and the JBOX should not exceed 24".
- ❸ JBOX – Junction box (Supplied by installer)
- ❹ Wiring (2 x 24VAC supply, 2 x Communication)
- ❺ Mounting Bracket – PYROSB - optional

### The PYROSENSE aerial sensors are supplied with:

1. A plastic cap, to protect the sensor from dust and debris for when the sensor is not in use (off season).

**Important!** The protective cap must be removed before use of the sensor.

**If the protective cap is not removed, the sensor will not detect snow!**

2. Plastic spikes, to be used if necessary, to keep birds off the sensor.

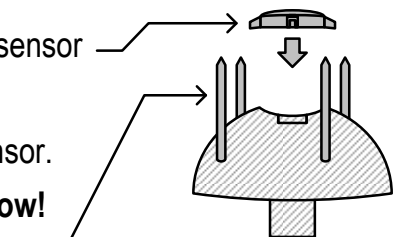

**PYROCON19**

Owner's manual & Technician Settings

Pg. 10

Tel: (856) 2882882  
Tel: +972-3-9626462  
Fax: +972-3-9626620  
support@meitavtec.com

 meitav-tec

# Installation and Wiring Connections – PYROSENSE

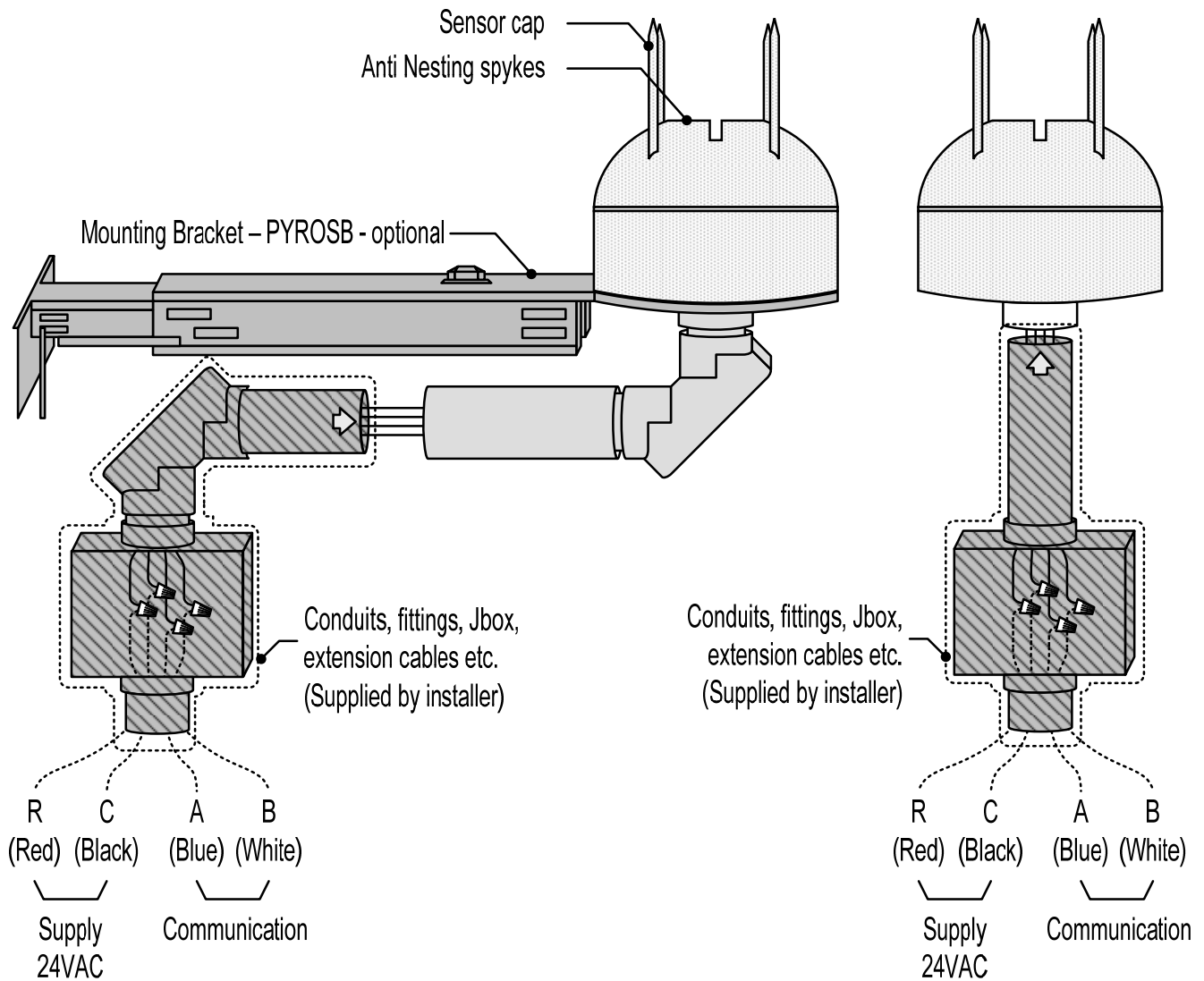

## Power cable (R,C)

18AWG - Up to 500ft / 150m  
 12AWG - Up to 1000ft / 300m

## Communication cable (A,B)

Jacketed shielded twisted pair 120 Ohm,  
 18AWG - Up to 500ft / 150m

## Power cable (R,C)

18AWG - Up to 500ft / 150m  
 12AWG - Up to 1000ft / 300m

## Communication cable (A,B)

Jacketed shielded twisted pair 120 Ohm,  
 18AWG - Up to 500ft / 150m

## Installation and Wiring Connections – PYROSENSE-GUTTER

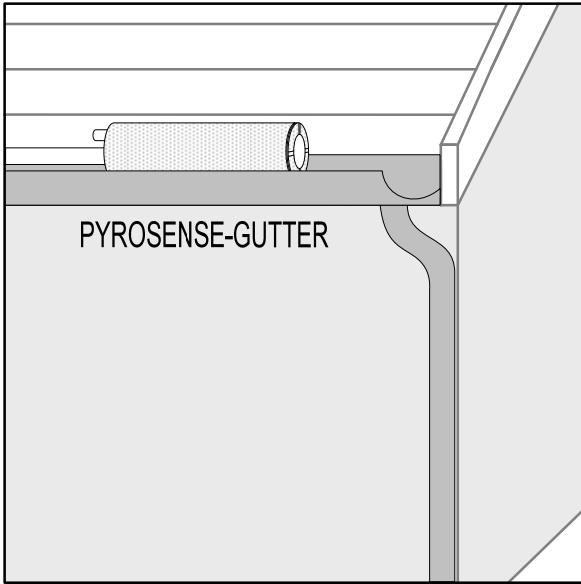

Gutter sensor installation

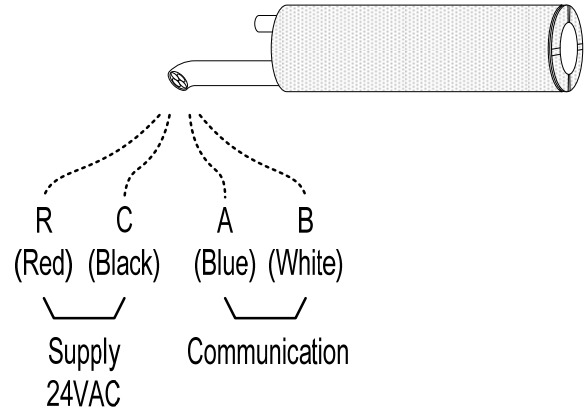

### Power cable (R,C)

18AWG - Up to 500ft / 150m  
12AWG - Up to 1000ft / 300m

### Communication cable (A,B)

Jacketed shielded twisted pair 120 Ohm,  
18AWG - Up to 500ft / 150m

## Installation and Wiring Connections – PYROSENSE-GROUND

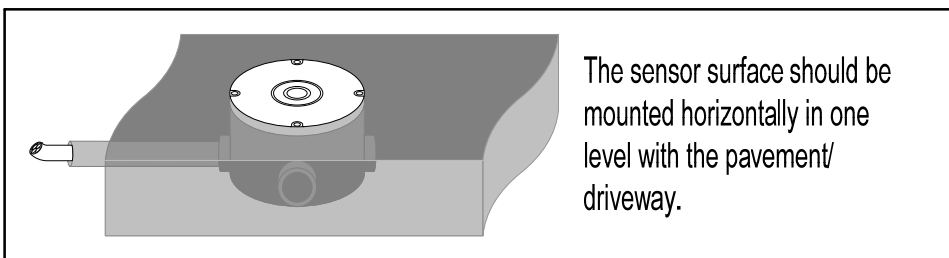
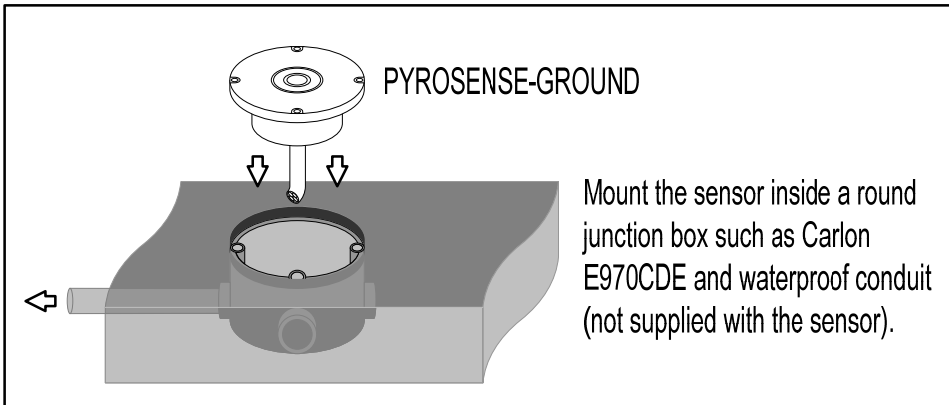

Ground sensor installation

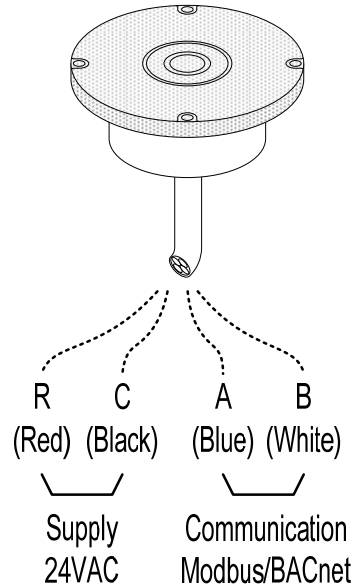

### Power cable (R,C)

18AWG - Up to 500ft / 150m  
12AWG - Up to 1000ft / 300m

### Communication cable (A,B)

Jacketed shielded twisted pair 120 Ohm,  
18AWG - Up to 500ft / 150m

## Operating instructions

### Green POWER lamp

- The green power lamp will light when power is supplied to the unit (120 VAC)



GFEP Test/Reset button

TEST GFEP (GREEN button)

GROUND FAULT RESET lamp will lit when the internal GFEP is tripped

RESET GFEP (RED button)  
- Press for 5 seconds

### Turning the system ON and OFF

- Press and hold the [ON] button for 0.5 seconds to turn the system ON or OFF.
- The words "ON" or "OFF" will appear on display.

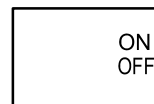

### Selecting temperature scale

- Press the [+] button for Celsius.
- Press the [-] button for Fahrenheit.

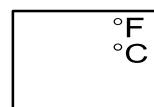

### Selecting Automatic or Manual mode

- Press the [SELECT] button to switch between modes:

#### "Automatic"

Heating will start and stop automatically depending on snow detection by the snow sensor/sensors.

#### "Manual ON"

Heating will start regardless of snow sensor measurements and will stop after a preset time (pls. refer to the "Manual ON" section in the technician settings P05).



Note: Mode will always return to "Automatic" after switching the unit OFF and ON.

### Heaters indication

The number beneath the heater icon indicate the heater stage (1 to 5).

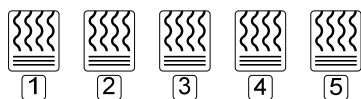

Black icon – Heater ON

White icon – Heater OFF



Heater ON



Heater OFF

Stg. Stg. Stg. Stg. Stg.  
1 2 3 4 5

### Snow flake icon and digital time indication

A solid snow flake icon will appear on display while sensing snow and during normal heaters operation.



A blinking snow flake icon will appear on display during heaters off delay or when manual mode is activated. The digital clock will count down the remaining time until the heaters are turned off.

The snow flake icon will disappear from display as long as the heaters are turned off.

## Technician settings

Use the technician settings to view and adjust the following parameters:

- P01 Temperature set point
- P02 Lower ambient temperature limit to stop heaters
- P03 Energy saving, upper slab temperature limit to stop heaters
- P04 Time delay before stopping the heaters
- P05 ON time for manual mode
- P06 Heaters cycle time / Splitting time
- P07 Sensors and heaters control logic
- P08 Snow sensor sensitivity
- P88 Snow detection threshold
- P09 Enable/Disable PYROSENSE sensors connected to system
- P10 Commissioning / Test mode
- P11 Master/Slave
- P12 Controller's MAC Address for BMS
- P13 Scan the system for new sensors
- P14 Reset PYRO sensors MAC Address
- P15 Offset for calibration of measured temperature

### Restore defaults

## Enter technician settings mode

- Move DIP switch S1 located on the side of thermostat to ON position.
- Press the [SELECT] and [+] buttons simultaneously to move forward to the next technician parameter.
- Press the [SELECT] and [-] buttons simultaneously to return to the previous technician parameter.

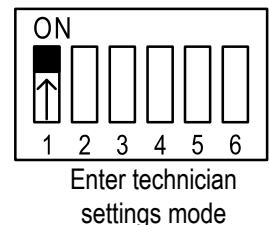

## Save changes and exit technician settings mode

- Move DIP switch S1 located on the side of thermostat to OFF position.

**Important: Changes made to technician parameters will not take effect as long as DIP switch S1 is in ON position.**

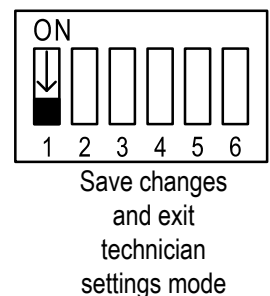

- The PYROCON19 will return to normal operation after leaving technician settings mode at OFF state.

↳ Cont'

## Technician settings

### P01 - Temperature set point

- Move DIP switch S1 located on the side of thermostat to ON position to enter technician settings mode.
- "P01" and the temperature set point will appear on display.
- Use the [+] and [-] buttons to adjust the temperature set point.  
Range: 14...59°F / -10...+15°C, default 37°F / +3°C

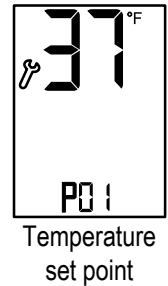

As long as the ambient temperature is lower than the temperature set point P01, the heaters will turn ON upon receiving a positive snow signal from the snow detector.

**The controller will read the ambient temperature from the connected sensors in the following priority:**

1. PYROSENSE – aerial sensor.
2. PYRO-GUTTER gutter sensor.
3. T2 sensor – When no aerial or gutter sensors are used.

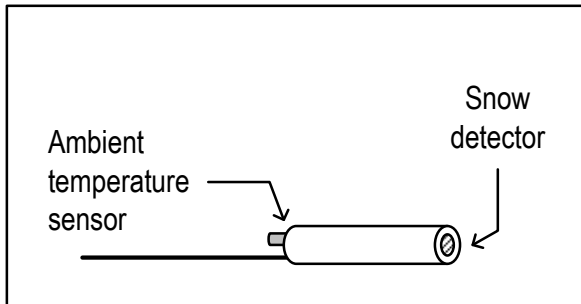

PYROSENSE-GUTTER

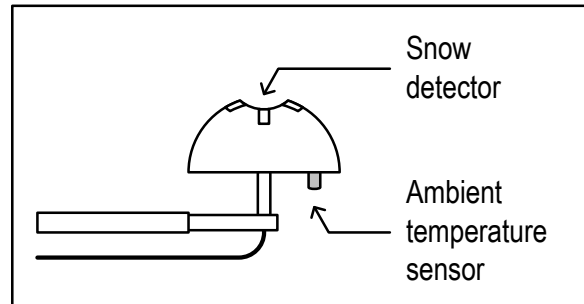

PYROSENSE

### P02 - Lower limit temperature for heating

- Press the [SELECT] and [+] buttons simultaneously.
- "P02" and the low limit temperature will appear on display.  
When the temperature on the temperature sensor drops below the low temperature limit, the heating system will stop.
- Use the [+] and [-] buttons to adjust the temperature set point.  
Range: -40...+23°F / -40...0°C     Default: -31°F / -35°C
- Press the [SELECT] and [+] buttons simultaneously again.
- The word "ON" or "OFF" will appear on display.
- Use the [+] and [-] buttons enable (ON) or disable (OFF) the P02 parameter.

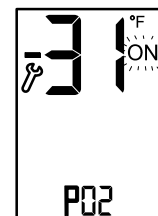
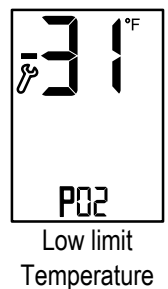

P02 enabled

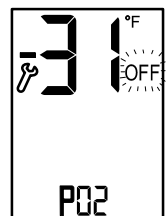

P02 disabled

If disabled, the heating system will operate without low temperature limitations.

↳ Cont'

## Technician settings (Cont')

### P03 – Upper limit temperature for heating

- Press the [SELECT] and [+] buttons simultaneously.
- “P03” and the slab upper limit temperature will appear on display.
- Use the [+] and [-] buttons to adjust the upper limit temperature.  
Range: +41...+122°F / +5...+50°C Default: 86°F / +30°C  
\*For numbers above 100, “100” will appear on display.
- Press the [SELECT] and [+] buttons simultaneously again.
- The word “ON” or “OFF” will appear on display.
- Use the [+] and [-] buttons enable (ON) or disable (OFF) the P03 parameter.  
If disabled, the heaters will work regardless of the upper limit.
- Press the [SELECT] and [+] buttons simultaneously again.
- The display will show the temperature on the upper limit sensor.

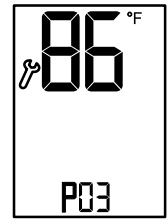

Upper limit temp.



P03 enabled

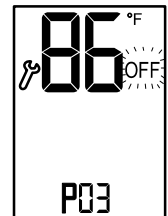

P03 disabled

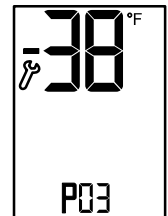

temperature on heaters sensor

### P04 -Time delay before stopping the heaters

- Press the [SELECT] and [+] buttons simultaneously.
- “P04”, “dL” and the time delay before stopping the heaters (Hold ON) will appear on display. The hours will blink.
- Use the [+] and [-] buttons to adjust the hours of the time delay.  
Range: 0...99 hours Default: 1 hours
- Press the [SELECT] and [+] buttons simultaneously again.
- The minutes will blink.
- Use the [+] and [-] buttons to adjust the minutes of the time delay.  
Range: 00...59 minutes Default: 30 minutes

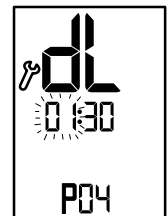

Time delay (hours)

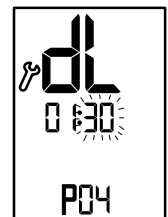

Time delay (minutes)

Note 1. The time delay countdown will start when the snow detection signal from snow sensor controlling the specific heater will switch from positive to negative.

Note 2. The staggering sequence will continue during the time delay.

Note 3. The heater icon will blink when the heater is in off delay time.

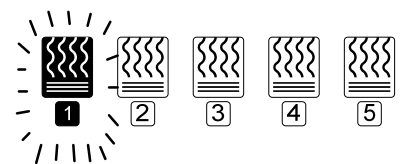

↳ Cont'



## Technician settings (Cont')

### P05 - Manual mode ON time

- Press the [SELECT] and [+] buttons simultaneously.
- "P05", "On" and the "Manual ON" mode time period will appear on display.  
The hours will blink.

The delay time parameter defines a time frame in which the heaters remain ON after receiving an "Manual ON" command.

- Use the [+] and [-] buttons to adjust the hours of the working time.

Range: 00...99 hours                      Default: 6 hours

- Press the [SELECT] and [+] buttons simultaneously again.
- The minutes will blink.
- Use the [+] and [-] buttons to adjust the minutes of the working time.

Range: 00...59 minutes                      Default: 00 minutes



Manual ON  
hours



Manual ON  
minutes

### P06 – Heaters cycle and splitting time

- Press the [SELECT] and [+] buttons simultaneously.
- "P06", "SP" and the splitting time will appear on display.

The minutes will blink.

The heaters cycle / splitting time parameter defines the working time of the heaters when working in sequence.

Example: the splitting time is set to 120 minutes and 4 heaters work in sequence, each heater will be ON for 30 minutes (120/4=30).

- Use the [+] and [-] buttons to adjust the splitting time.

Range: 1...600 minutes                      Default: 120 minutes.

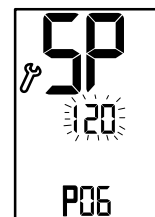

Splitting time

↳ Cont'

## Technician settings (Cont')

### P07 - Heaters outputs logic controlled by PYRO sensors or by 3<sup>rd</sup> party sensor

- Press the [SELECT] and [+] buttons simultaneously.
- "P07" and the figures "0", "1", "2" or "3" will appear on display.
- Use the [+] and [-] buttons to define the heaters logic (model dependent) as follows:

Value	Heaters controlled by PYROSENSE / PYROSENSE-GROUND		Heaters controlled by PYROSENSE-GUTTER (when connected)	Heaters controlled by 3 <sup>rd</sup> Party sensor
0 (default)	Heaters 1,2,3,4,5*		-	-
	Heaters 1,2,3,4		Heater 5	-
1	Heaters 1,2,3,4		-	Heater 5
2	-		-	Heaters 1,2,3,4,5
	-		Heater 5	Heaters 1,2,3,4
3	Snow on any sensor will trigger all heaters			
4	Heaters 1,2 by PYROSENSE	Heaters 3,4,5*	-	-
	Heaters 1,2 by PYROSENSE	Heaters 3,4	Heater 5	-

\*Heaters 4 and 5 will turn ON and OFF together.

The snow sensors will control heaters upon the following logic:

1 Sensor	2 Sensors	3 Sensors	4 Sensors
Heaters 1,2,3,4	Sensor 1 – Heaters 1,2 Sensor 2 – Heaters 3,4	Sensor 1 – Heater 1 Sensor 2 – Heater 2 Sensor 3 – Heaters 3,4	Sensor 1 – Heater 1 Sensor 2 – Heater 2 Sensor 3 – Heater 3 Sensor 4 – Heater 4

Note: Sensors order (1,2,3,4) is defined by their MAC address order.

example: 3 sensors connected:

- 1 x PYROSENSE (MAC 1 – Sensor 1) - Will control heater 1
- 1 x PYROSENSE (MAC 2 – Sensor 2) - Will control heater 2
- 1 x PYROSENSE-GROUND (MAC 5 – Sensor 3) - will control heaters 3,4

↳ Cont'

## Technician settings (Cont')

### P08 - Snow sensor sensitivity

- Press the [SELECT] and [+] buttons simultaneously.
- "P08" and the snow sensor sensitivity value will appear on display.
- Use the [+] and [-] buttons to adjust the sensitivity.

Range: 20...80 % (20% - Less sensitive, 80% - more sensitive), Default: 50 %

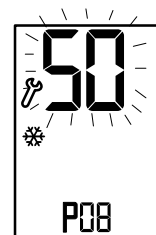

P08  
Snow sensor  
sensitivity

### P88 - Snow detection threshold

- Press the [SELECT] and [+] buttons simultaneously.
- "P88" and the snow sensor threshold will appear on display.
- Use the [+] and [-] buttons to adjust the threshold.

Range: 0...60 minutes

Default: 1 minutes

If the threshold is not reached, the logic of turning the heaters either ON or OFF will not be affected by snow detection.

During countdown to threshold time, the snow flake icon will flash.

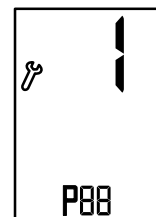

P88  
Snow detection  
threshold

↳ Cont'

## Technician settings (Cont')

### P09 – Enable/Disable PYROSENSE sensors connected to system

Important! When new sensors are connected to the system, please refer to technician parameter P13 - scan the system for new sensors.

After the scanning process explained in P13 completes, the sensors found can be enabled or disabled.

- Press the [SELECT] and [+] buttons simultaneously.
- "P09" and the MAC address of the first sensor will appear on display.
- Use the [+] and [-] buttons to select sensor.  
When selected, Press the [ON] button to enable (ON) or disable (OFF) the sensor.
- Repeat the operation for other sensors (1-8) – default: 1-ON, 2-8 OFF.

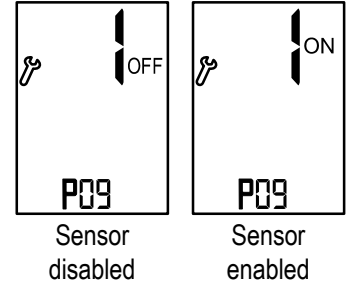

Sensors MAC Address:

- MAC 1 - PYROSENSE #1 (1<sup>st</sup> aerial sensor)
- MAC 2 - PYROSENSE #2 (2<sup>nd</sup> aerial sensor)
- MAC 3 - PYROSENSE #3 (3<sup>rd</sup> aerial sensor)
- MAC 4 - PYROSENSE #4 (4<sup>th</sup> aerial sensor)
- MAC 5 - PYRO-GROUND #1 (1<sup>st</sup> ground sensor)
- MAC 6 - PYRO-GROUND #2 (2<sup>nd</sup> ground sensor)
- MAC 7 - PYRO-GUTTER #1 (1<sup>st</sup> gutter sensor)
- MAC 8 - PYRO-GUTTER #2 (2<sup>nd</sup> gutter sensor)

- After enabling required sensors, an error message "SensErr" and the number of the first missing sensor will appear on display indicating that this sensor is not connected to the system.
- Connect the first sensor to the system and wait for the error message to disappear or change to the next missing sensor.
- Connect the second sensor to the system and repeat the operation.
- Repeat the operation for all sensors in the system.

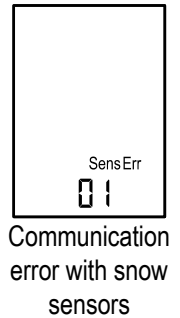

↳ Cont'

## Technician settings (Cont')

### P10 - Test conditions mode / Technician commissioning mode

Turn ON test conditions to check the functionality of the system regardless of sensors parameters (i.e. during the summer).

In test conditions, the Ambient temperature is always  $-5^{\circ}\text{C}/23^{\circ}\text{F}$ .

Note: In order to trigger the system and activate the heaters, use some water to wet the circuit on top of the snow sensor.

- Press the [SELECT] and [+] buttons simultaneously.
- "P10" will appear on display. The hours will blink.
- Use the [+] button to enter test/commissioning mode – the word "Test" will appear on display.
- Use the [-] button to manually exit test/commissioning mode – the word "Test" will disappear from display.

Note: If the technician did not manually exit test/commissioning mode, the unit will automatically return to normal mode after 5 hours.

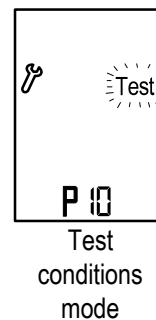

### P11 – Master/Slave

- Press the [SELECT] and [+] buttons simultaneously.
- "P11" will appear on display.
- Use the [+] and [-] buttons to select between:
  - "MA" - Master (When using one PYROCON19 or when controlling other PYROCON19 devices connected to A,B as slaves) - default
  - "SL" - Slave (controlled by another PYROCON19 connected to A,B)

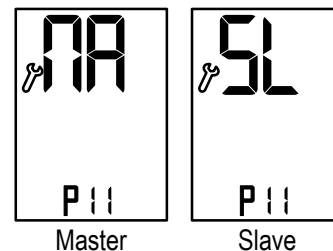

↳ Cont'

## Technician settings (Cont')

### P12 – Controller's MAC Address

- Press the [SELECT] and [+] buttons simultaneously.
- "P12" will appear on display.
- Use the [+] and [-] buttons to set the controller's MAC address:
  - For controller set by P11 as Master –  
Address range for BMS 1...63, default 9
  - For controller set by P11 as Slave –  
Address range 14...16, default 14

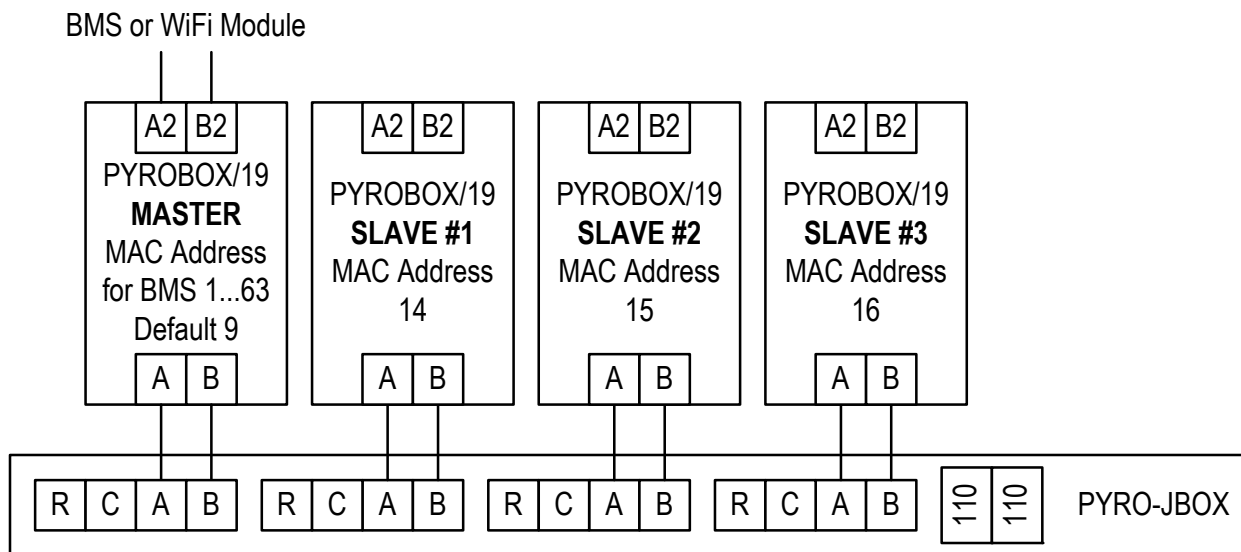
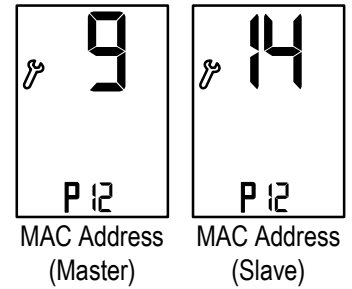

#### Notes:

1. Use multiple Junction Boxes to connect up to 6 sensors and 3 PYROBOX/19 slaves
2. A,B Communication wire to slaves: flexible twisted pair overall foil + braid shielded and overall jacketed with a flexible PVC compound, 2000 ft, (600 m) maximum length.

↳ Cont'

## Technician settings (Cont')

### P13 – Scan the system for new sensors

Important! Disconnect power to the main board before installing new sensors.

The system can recognize up to 3 different sensors in one scanning loop:

- One PYROSENSE aerial, One PYROSENSE-GROUND and One PYROSENSE-GUTTER

If more than one sensor of the same type is used, connect the first sensor and run the scanning procedure. Then, disconnect power, connect the second sensor of each type, reconnect power and run the scanning process again.

Example:

The system will operate Three PYROSENSE Aerial sensors, Two PYROSENSE-GUTTER sensors and One PYROSENSE-GROUND sensor.

Step 1 – Disconnect power, Connect the first PYROSENSE, PYROSENSE-GUTTER and PYROSENSE-GROUND. Reconnect power and run the scanning procedure.

Step 2 – Disconnect power, Connect the second PYROSENSE and PYROSENSE-GUTTER, Reconnect power and run the scanning procedure.

Step 3 – Disconnect power, Connect the third PYROSENSE, Reconnect power and run the scanning procedure.

Scanning procedure:

- Press the [SELECT] and [+] buttons simultaneously.  
“P13” will appear on display.
- Press the [+] button to begin the scan. The system will run through the available MAC addresses and recognize a new sensor.
- When a new sensor is found, it will be automatically assigned with the next available MAC address which will be displayed on the screen for a few seconds.

Then the system will continue the scanning loop trying to find other sensors.

The loop will complete when the scanning counter reaches the number 13.

- If required (when more than one sensor of each type is being used) disconnect power, connect the other sensors to the system and run the scanning procedure again.
- Repeat these steps for all the new sensors.

Important!

Make sure to enable the sensors found using technician parameter P09.

Make a note of the MAC addresses given to each sensor for future maintenance.

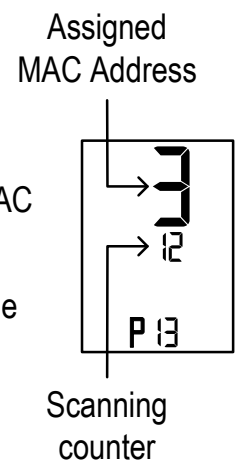

↳ Cont'

## Technician settings (Cont')

### P14 – Reset PYRO Sensors MAC Address

- Press the [SELECT] and [+] buttons simultaneously.
- “P14” will appear on display.
- Use the [+] and [-] buttons to select sensor by its MAC address.
- Press the [ON] button to reset the sensor’s MAC address.
- If required, run the sensors scanning procedure again – see P13.

### P15 – Offset for calibration of measures temperature

- Press the [SELECT] and [+] buttons simultaneously.
- “P15” will appear on display.
- Use the [+] and [-] buttons to adjust the offset.  
Range: -9...+9°F / -6...+6°C      Default: 0°F / 0°C

### Save changes and return to normal display

- In order to save changes and return to normal display, move DIP switch S1 back to OFF position.

**Important: Changes made to technician parameters will not take effect as long as DIP switch S1 is in ON position.**

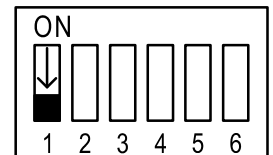

- The PYROCON19 will return to normal operation after leaving technician settings mode at OFF state.

### Restore default values

**Important: Make sure the unit is turned OFF (the word “OFF” should appear on display).**

- Move DIP switch S1 to ON position.
- Press and hold the [ON] button for 10 seconds. The thermostat will beep.
- Move DIP switch S1 back to OFF position.



## Technician settings (Cont')

### DIP switch S2 - Short measuring times (test only)

- Use DIP switch S2 to short the
  - “ON” - Short measuring times – for test/commissioning only (measuring times will be divided to 60).
  - “OFF” - Normal operation.

Short measuring times: A real 1 hour will take 1 minute and a real 1 minute will take 1 second.

### DIP switches S3 and S4 – heaters sequencing logic

- Use DIP switches S3 and S4 to define the sequencing logic of the heater (zones) as follows:

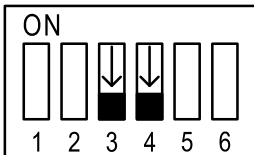

S3 OFF, S4 OFF

All 4 outputs work per request from the snow sensor(s)

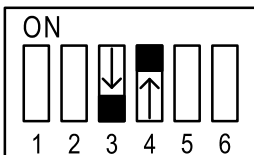
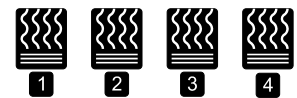

S3 OFF, S4 ON

Outputs 1+3 and outputs 2+4 work together (according to splitting time)

Note: Do not use this configuration with more than two snow sensors connected.

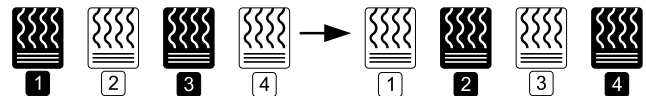

S3 ON, S4 OFF

Outputs 1,2 and 3 work in sequence (according to splitting time) and output 4 works continuously.

Note: Do not use this configuration with more than two snow sensors connected.

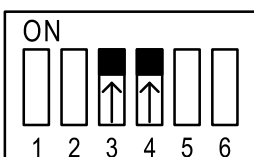
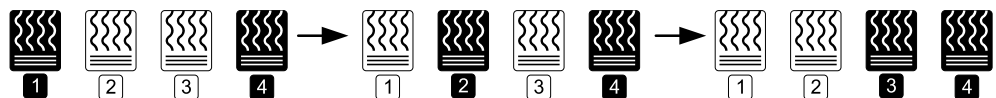

S3 ON, S4 ON

All 4 outputs work in sequence (according to splitting time)

Note: Do not use this configuration with more than two snow sensors connected.

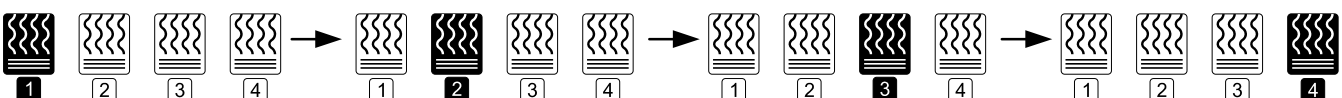

Note: if output 5 is set to work together with outputs 1-4, (see “Heater output no. 5 logic” in the technician settings), it will operate the same as output 4.

## Technician settings (Cont')

### Enable/Disable zones

Follow the steps below to enable or disable each of the 5 zones.

By default, all zones are enabled.

1. Turn the thermostat **OFF**.
2. Press and hold both the [+] and the [-] buttons simultaneously for 10 seconds.
3. Choose the required zone using the [Select] button. Selected zone number will appear on display and the heater icon will flash.
4. Press the [ON] button once to enable the selected zone (black heater icon).
5. Press the [ON] button twice to disable the selected zone (white heater icon).
6. Repeat steps above 3 to 5 for any required zone.
7. Press and hold both the [+] and the [-] buttons simultaneously again for 5 seconds to return to normal display.

Note: Disabled zones will be ignored in splitting time calculations:

Example: the splitting time is set to 60 minutes and heaters are set work in sequence.

3 Heaters enabled and 1 heater disabled.

With all heaters enabled: Each heater will be ON for 15 minutes ( $60/4=15$ ).

With 3 heaters enabled and 1 heater disabled: Each heater will be ON for 20 minutes ( $60/3=20$ ).

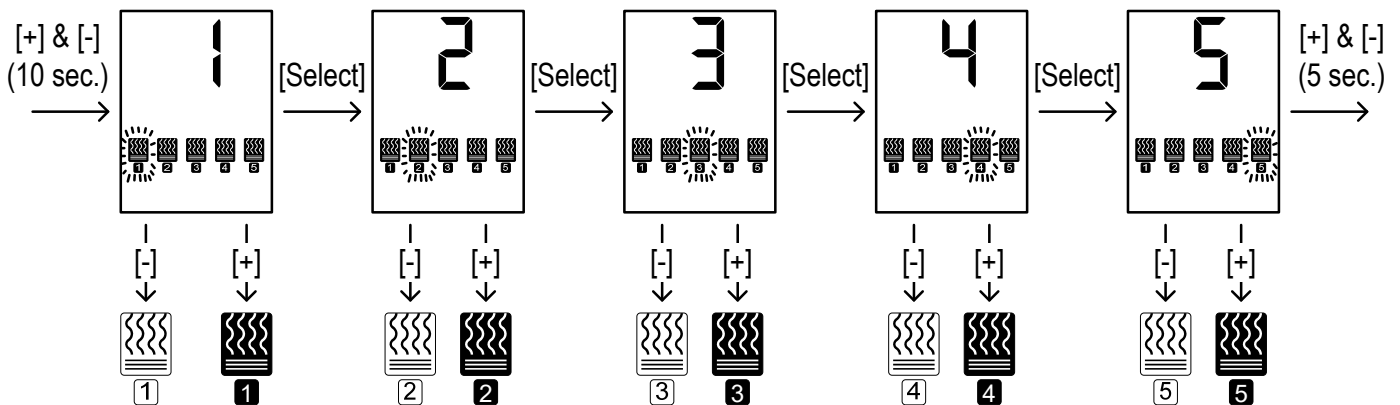

 Black icon – Zone enabled

 White icon – Zone disabled

## Technician settings (Cont')

### Select Critical zones

Follow the steps below to set each of the active zones as Critical or Non-critical zone.

By default, all zones are critical.

1. Turn the thermostat **ON**.
2. Press and hold both the [+] and the [-] buttons simultaneously for 10 seconds.
3. Choose the required zone using the [Select] button. Selected zone number will appear on display and the heater icon will flash.
4. Use the [+] button to set zone as Critical zone ("ON" will appear on display).
5. Use the [-] button to set zone as Non Critical zone ("OFF" will appear on display).
6. Repeat steps above 3 to 5 for any required zone.
7. Press and hold both the [+] and the [-] buttons simultaneously again for 5 seconds to return to normal display.

Note: As long as it snows, only critical zones will participate in the staggering scenario.

Once the snowing stops, the active zone will complete its cycle followed by one more full cycle of each critical zone (including another full cycle of the active zone).

After that, and for the rest of the "time delay before stopping the heaters" set by parameter P04, the system will start staggering between the non-critical zones .

Example:

- Zones 1,2,3,4 enabled
- Zones 1,2 Critical
- Zones 3,4 Non-critical
- Sequencing logic 1+3 together, 2+4 together
- Time delay before stopping the heaters: P04 = 9 hours.
- Splitting time: P06 = 120 minutes.

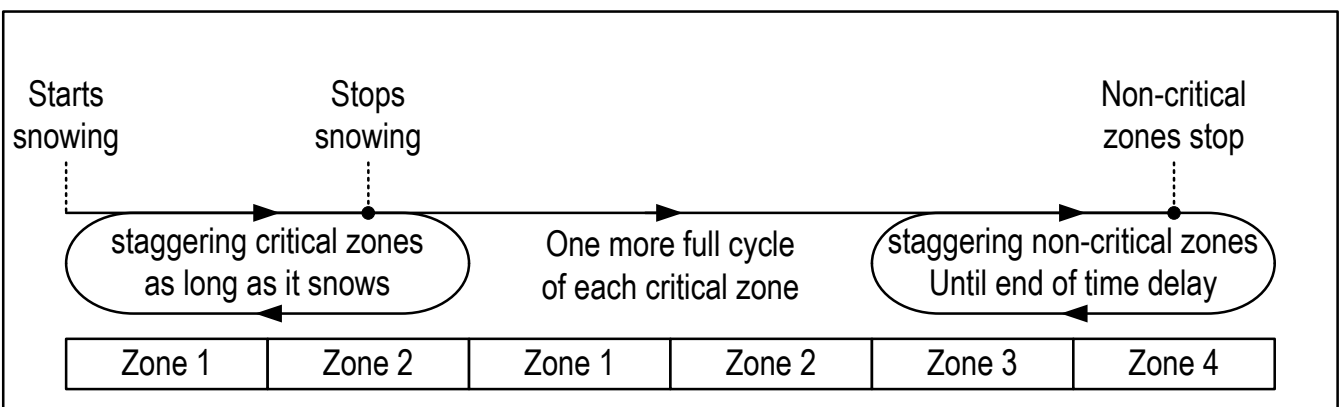

## BMS Communication Protocol – BACnet/Modbus

- Use DIP switch S6 located on the side of thermostat to select BMS (A1,B1) network protocol:

S6 ON – BACnet, S6 OFF – MODBUS

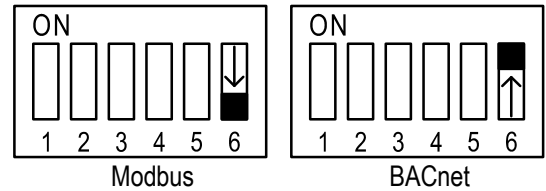

Important!

When using Master-Slave logic, the BMS communication protocol should be set only on the Master unit. DIP switch S6 on the Slave unit must always be set to OFF position, regardless of communication protocol.

## Temperature reading errors

Ambient temperature sensor readings (on snow sensor) are out of reliable measuring range

Ambient temperature < -9°F/-23°C

Ambient temperature > 54°F/12°C

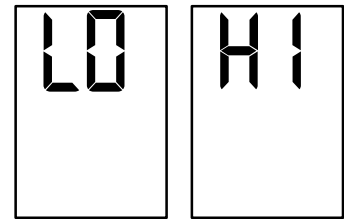

The system will continue to operate using constant predefined values.

In addition, the display will alternate between “LO” and -11°F/-24°C for low temperature readings, and between “HI” and 55°F/13°C for high temperature readings.

### SensErr ## – Communication error with one (or more) snow sensors

If the system is configured to work with more than 1 snow sensor, the faulty snow sensor number will appear on display: 01...08.

The system will use readings from snow sensor 1 instead of the missing readings from the faulty snow sensor.

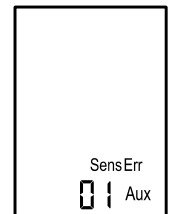

### SensErr 1 – Temperature measured by upper limit sensor is more than the upper limit temperature configured in P03.

The system will continue to operate regardless of the upper limit temperature.

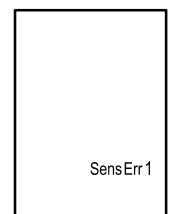

### SensErr 2 – Upper limit temperature sensor is not connected or short circuit

The system will continue to operate regardless of the upper limit temperature.

Required actions:

- Refer to P03 section of the technician settings.
- Check the temperature value and disable the sensor if needed.
- Replace the sensor.

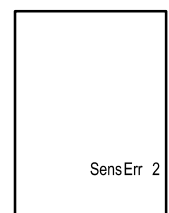

## Object list – Modbus (DIP switch S6 = OFF)

MODBUS RTU Mode, Address Slave 1-127,  
 Baud rate: 9600, n, 8, 1  
 Supported Commands:  
 0x03 = Read Holding Registers (for all).  
 0x06 = Preset Single Register (For R/W registers only),  
 Command 0x2B is used to identify controller

Vendor Url = "meitavtec.com"  
 Product Name = "Pyrocon 19"  
 User Application Name = "Pyrocon 19"  
 VendorName = "Meitav-Tec".  
 ProductCode = "19418301"  
 MajorMinorRevision = "0.1.2257"

N°	Description	Type	Value (Range)	Default	Perm.	TS
1000	Temperature Outside	AV	14°F... 59°F (-10°C...+15°C)	X	R	
1001	Snow Detection	BV	0..1 (1 - detected)	X	R	
1002	Manual Mode	BV	0 –auto ,1 -manual	0	R/W	
1003	On/Off	BV	1 – On, 0 – Off	0	R/W	
1004	Time Delay Until Turn Off Heaters	AV	0.....2880 min	x	R	
1005	Heater 1	BO	1 – On, 0 – Off	X	R	
1006	Heater 2	BO	1 – On, 0 – Off	X	R	
1007	Heater 3	BO	1 – On, 0 – Off	X	R	
1008	Heater 4	BO	1 – On, 0 – Off	X	R	
1009	Heater 5	BO	1 – On, 0 – Off	X	R	
1010	Set Point	AV	14°F... 59°F (-10°C...+15°C)	+37°F(3.0°C)	R/W	P1
1011	Low Limit Heat	AV	-40°F... +32°F (-40°C...0°C)	-31°F(-35°C)	R/W	P2
1012	Heaters Off Delay when snow stops	AV	0 ... 540 min	90 min	R/W	P4
1013	Manual Period Time	AV	10 ... 2880 min	240 min	R/W	P5
1014	Snow Sensor Sensitivity	AV	20 ...80%	50%	R/W	P8
1015	Snow Detection Threshold	AV	0 ... 60 min	1 min	R/W	P88
1016	Heater Mode	AV	Heater Mode	0	R/W	P7
1017	Staggering Time	AV	1 ... 600 min	120 min	R/W	P6
1018	Commissioning Mode	BV	1 – On, 0 – Off	0	R/W	P10
1019	C/F Scale	BV	1 - °C / 0 -°F	0	R/W	
1020	Upper Limit	AV	+41°F... +113°F (+5°C...+45°C)	+86°F(+30°C)	R/W	
1021	Upper Limit Sensor Effective	AV	+41°F... +113°F (+5°C...+45°C)	X	R	
1022	Upper Limit Enable	BV	0 – disable , 1 – enable	0 (disable)	R/W	
1023	Ground Sensor Detection	BV	0 ...1 (1 - detect)	X	R	
1024	Gutter Sensor Detection	BV	0 ...1 (1 - detect)	X	R	
1025	3 <sup>rd</sup> Party Sensor Detection	BV	0 ...1 (1 - detect)	X	R	
1026	Restore Default	BV	0...1 (1 - restore)	0	R/W	
1027	Ground Fault	BV	0 – Ok, 1 – Fault	X	R	
1029	Sensors Error	AV	0...99	X	R	

The MODBUS Register No. X is addressed in the MODBUS Register Address (PDU) X-1.

**All Registers are signed Integer 16 bit.**

## Object list – BACnet (DIP switch S6 = ON)

BACnet MST5 Baud rate: 9600, 19200, 38400, 76800 no parity, 8 data bits, 1stop bit

N°	Object	Value	Object name	Default	Perm.	TS
1	AnalogValue_#0	-10...15°C (14...59°F)	SetPoint	3°C (37°F)	R/W	
2	AnalogValue_#1	-40...0°C (-40...32°F)	LowLimitHeat	-35°C (-31°F)	R/W	
3	AnalogValue_#2	0...540 min	HeatersOffDelay	90 min	R/W	
4	AnalogValue_#3	10...2880 min	ManualPeriodTime	240 min	R/W	
5	AnalogValue_#4	20...80%	SnowSensorSensitivity	50 %	R/W	
6	AnalogValue_#5	0...60 min	SnowDetectionThreshold	1 min	R/W	
7	AnalogValue_#6	1...600 min	StaggeringTime	120 min	R/W	
8	AnalogValue_#7	-40...35°C (-40...95°F)	TemperatureOutside	-	R	
9	AnalogValue_#8	0...2880 min	HeatersOffTimeDelay	-	R	
10	AnalogValue_#9	0...4	HeaterMode	0	R/W	
11	AnalogValue_#15	5...50°C (41...122°F)	UpperLimit	30°C (86°F)	R/W	
12	AnalogValue_#16	5...50°C (41...122°F)	UpperLimitSensorEffective	-	R	
13	AnalogValue_#30	0...99	SensorsError	-	R	
14	BinaryOutput_#0	1-On,0-Off	Heater 1	-	R	
15	BinaryOutput_#1	1-On,0-Off	Heater 2	-	R	
16	BinaryOutput_#2	1-On,0-Off	Heater 3	-	R	
17	BinaryOutput_#3	1-On,0-Off	Heater 4	-	R	
18	BinaryOutput_#4	1-On,0-Off	Heater 5	-	R	
19	BinaryValue_#0	1-On,0-Off	OnOff	0-Off	R/W	
20	BinaryValue_#1	1-On,0-Off	Manual Mode	0-Off	R/W	
21	BinaryValue_#2	1-On,0-Off	C_F_Scale	0-Off	R/W	
22	BinaryValue_#3	1-On,0-Off	SnowDetection	0-Off	R	
23	BinaryValue_#4	1-On,0-Off	CommissioningMode	0-Off	R/W	
24	BinaryValue_#5	1-On,0-Off	RestoreDefaults	0-Off	R/W	
25	BinaryValue_#9	1-On,0-Off	GroundSensorDetection	0-Off	R	
26	BinaryValue_#10	1-On,0-Off	UpperLimitEnable	0-Off	R/W	
27	BinaryValue_#11	1-On,0-Off	GutterSensorDetection	0-Off	R	
28	BinaryValue_#12	1-On,0-Off	3rdPartySensorDetection	0-Off	R	
29	BinaryValue_#14	1-On,0-Off	GroundFault	0-Off	R	

# Appendix 1

## Calibrating and testing the internal GFEP

The GFEP (Ground Fault Equipment Protection) is designed to provide protection for electrical equipment. The "ON" Time Delay and Current Trip should be configured to match application requirements.

**"ON" Time delay**  
 Turn clockwise to increase  
 Counter-clockwise to decrease  
 (Default: Minimal time delay)

**Tripped relay LED indicator**

**Current Trip - % full scale**  
 (model dependent – see table)  
 (Default: 20%)

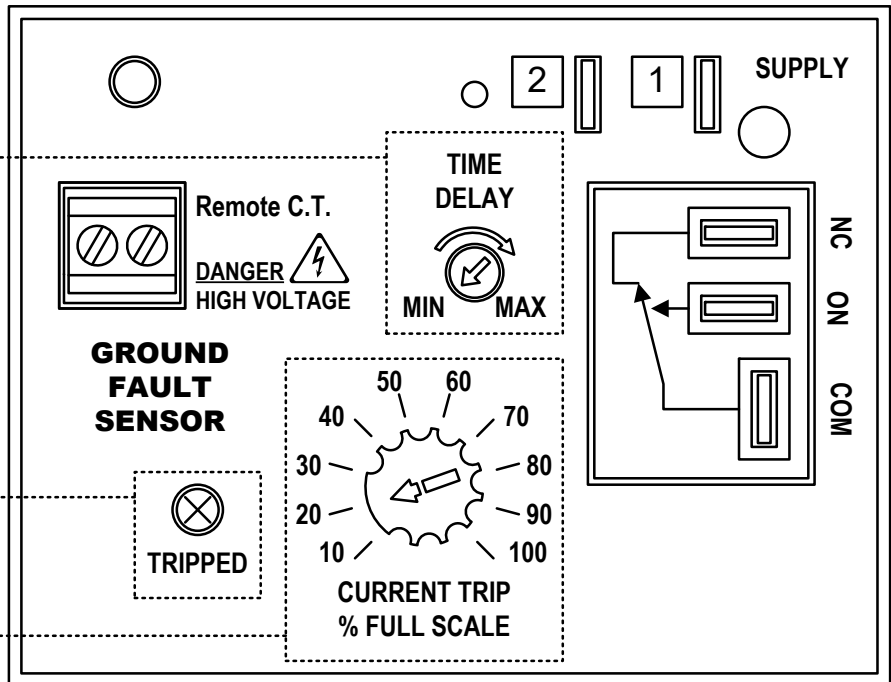

Indicator (%)	Current trip (Amps)	
	PYROBOX5/19	PYROBOX3/3C/19
10	0.1	0.01
20	0.2	0.02
30	0.3	0.03
40	0.4	0.04
50	0.5	0.05
60	0.6	0.06
70	0.7	0.07
80	0.8	0.08
90	0.9	0.09
100	1.0	0.10

### GFEP TEST/RESET

The GFEP should be tested monthly. Press the GREEN GFEP TEST button located on the PYROBOX/19 door for to trip the outlet and break the circuit. The RED internal LED on the GFEP and the RED external lamp on the box door should lit and the words "Ground Fault" should appear the display. Press the RED RESET GFEP button on the PYROBOX/19 door for 5 seconds to return to normal operation and reestablish power and protection.

TEST GFEP (GREEN button)

GROUND FAULT RESET lamp will lit when the internal GFEP is tripped

RESET GFEP (RED button)  
 - Press for 5 seconds





**Tel: (856) 2882882**

**Tel: +972-3-9626462**

**Fax: +972-3-9626620**

**support@meitavtec.com**

**www.meitavtec.com**