

Compact Heavy Duty Unit Heater SKB Series



Model Code:

SKB	24	05	1	T	B
A	B	C	D	E	F

- A: Series
- B: 20 - 208V
24 - 240V
- C: Watts
- D: Single Phase
- E: Thermostat
- F: Bracket



Kraft box packaging



- Spiral finned element
- Permanently lubricated motor
- Patented Smart Limit® protection
- High efficiency aluminum fan blade
- Built-in thermostat
- Universal mounting bracket
- Standard color: Gray
- 3-year limited warranty
- Adjustable louvers
- Power & Over-temp indicating lights
- High /Low switch & fan delay*



The SKB Compact Heavy Duty Unit Heater

The SKB compact heavy duty unit heater is designed for use as primary or supplemental heat sources in large or exposed areas, including commercial stores, workshops, barns, storage shed and garages to prevent freezing. Spiral finned steel elements and high air volume (CFM) ensure efficient heat exchange producing cooler element operation, prolonging heater life. By combining the highest quality components with a dynamically balanced fan blade, the SKB unit heater will provide years of trouble-free service. Includes both a power on indicating light and a red caution light that comes on if the heater stops due to the over temperature limit tripping. A universal wall/ceiling bracket provides for quick and simple installation. The built-in thermostat turns the heater on and off to maintain the desired room temperature.

Ordering Information - single phase

MODEL	UPC	KW	BTUH	PHASE	VOLTS	AMPS	MOTOR HP	CFM	TEMP. RISE	AIR THROW	MAX. MOUNT	WT. (lbs.)
SKB2007-1-T-B	13414	7.5	25.6	1	208	36.1	16W	690	34°	20ft.	9ft.	45.0
SKB2009-1-T-B	13415	9.2	31.4	1	208	44.2	25W	800	40°	24ft.	10ft.	45.0
**SKB2405-1-T-B	13410	5	17	1	240/208*	20.8/18	9W	520	30°	15ft.	8ft.	30.5
SKB2407-1-T-B	13411	7.5	25.6	1	240/208*	31.2/27	16W	690	34°	20ft.	9ft.	45.0
SKB2410-1-T-B	13412	10	34.1	1	240/208*	41.6/36.1	25W	800	40°	24ft.	10ft.	45.0

*Dual rated heaters will draw 13% less amps and 25% less wattage when operated at 208V.

**High Low switch & fan delay not available in 5kW unit

Field Mount Accessories

MODEL	DESCRIPTION	VOLTAGE	CONTROL VOLTAGE	RESISTIVE RATING	SWITCH ACTION
RC840T-240/U	Electronic Heat Relay With a 24V-208/240V Transformer	240/208V	24V	22A	SPST
RC840T-277/U	Electronic Heat Relay With a 24V-277V Transformer	277V	24V	19A	SPST
24A01G-3	Mechanical Heat Relay With a 24V-240V Transformer	240V	24V	25A	SPST
24A05A-1	Mechanical Heat Relay With a 24V-120V Transformer	120V	24V	25A	SPST
24A05E-1	Mechanical Heat Relay With a 24V-208V Transformer	208V	24V	22A	SPST
24A06G-1	Mechanical Heat Relay With a 24V-240V Transformer (Dual Circuit)	240V	24V	25A	SPST - Dual Circuit

Compact Heavy Duty Unit Heater SKB Series

Engineering Specifications

Contractor shall supply and install SKB Series unit heaters manufactured by King Electrical Mfg. Company.

Construction: All exterior and interior metal enclosure parts are made from 20 gauge electrogalvanized Steel with a rust inhibiting baked enamel finish. Rounded corners give it an attractive modern appearance.

Adjustable Outlet Louver: Louvers direct air up or down as needed.

Rear Intake Screen: Heavy gauge steel screen protects against foreign objects making accidental contact with the rotating fan blade.

Spiral Fin Elements: The metal sheath element is copper brazed with spiral fins then molded into a coil configuration. This combination produces the best heat transfer while eliminating the potential for hot spots by positioning the element in the maximum airflow stream.

Aluminum Fan Blade: Axial flow-type fan mounted directly to the motor shaft for maximum efficiency.

Built-in Thermostat: Single pole factory installed hydraulic capillary tube thermostat for precision heating control. Operating range 40° to 90° F.

Red Caution Light: Comes on if high temperature safety limit trips.

Yellow Power on Light: Gives visual indication that the heater is turned on.

*** High/Low Switch:** Provided on 7.5kw & 10kw models. Low setting reduces wattage in half. Fan delay keeps fan running after thermostat cycles off to dissipate all the heat from the elements, making the heater more efficient and prolonging the life of the elements.

Two Pole Contactor: Provided on 7.5kw & 10kw models. Breaks both L1 and L2 of the power supply wires, the control circuit operates at 240V.

Electrically Held Thermal Overload: Heaters shall be equipped with King's patented Smart Limit Protection®, which disconnects the heater when an over temperatures condition occurs. If the Smart Limit trips, it will remain open and will not automatically reset until the thermostat or circuit breaker is turned off for a few minutes. After the overload switch cools the power can be turned back on and the heater will operate again. This keeps the heater from repeatedly cycling allowing the user to determine the cause of the over temperature condition such as an object being placed in front of heater.

Totally Enclosed Fan Motor: Permanently lubricated long life, unit bearing with 20cc of oil. Epoxy-coated motor with enclosed rotor resists moisture and corrosion for long-lasting, trouble-free operation.

Easy Installation: A quick access panel located on the bottom of the heater allows for quick wiring and easy maintenance for the life of the heater. Includes universal wall/ceiling bracket for simple installation.

Approvals: cULus (E41422)

• SKB Wall/Ceiling Bracket Included

Unit heater brackets can be used for mounting on ceiling or wall. 3/8" threaded hole on top of unit heater can also be used with threaded rod to drop the unit closer to the floor.

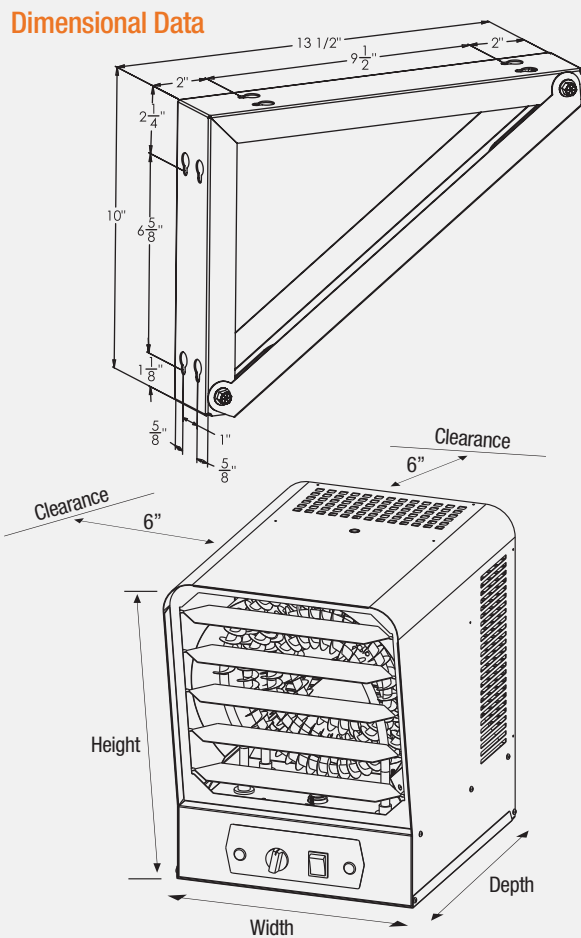

HEATER MODEL	HEIGHT	DEPTH	WIDTH
5kW	15.5"	12"	12.5"
7.5kW	16.25"	16.5"	12.5"
10kW	16.25"	16.5"	12.5"