



SUBMITTAL SHEET

Job Name: _____ Submitted By: _____ Date: _____

Location: _____

Architect: _____

Engineer: _____ Approved By: _____ Date: _____

Contractor: _____

Submitted By: _____

King Contact: _____

Quotes@king-electric.com

Date: _____

Tag	Qty	Item Number	Watts	Volts	PH	Amps	Weight

Accessories

Tag	Qty	Item Number

Explosion-Proof Heater Model FX6



Model Code:

FX6	480	3	60	300	T
A	B	C	D	E	F
A: Model Series, 5th Generation					
B: 208V, 240V, 480V, 600V					
C: 1-Phase, 3-Phase					
D: 50 Hertz, 60 Hertz					
E: Heater Kilowatts					
F: Built-In Thermostat					



- Rated for Class 1, Div. 1 & 2 applications
- Explosion proof motor
- Aluminum fan
- 2 levels of over temp protection
- Multiple wattages available
- Wall or ceiling mount
- 14 gauge powder coated steel

Explosion-Proof Heater

FX6 heaters are cULus certified for use in hazardous locations. They are designed for the harshest environments such as: dry indoor industrial applications, oil refineries, petrochemical plants, pulp and paper mills, grain elevators, hazardous waste storage facilities, wastewater treatment plants, etc., where specific explosive gases or dusts may be present. The FX6 offers a larger junction box for easier installation, additional limit controls and a heavy duty core. The heater core assembly is contained in a sturdy, epoxy-coated 12-gauge steel cabinet, which also carries the motor and fan assembly. Adjustable louvers allow directional control of the airflow. A narrow gap, two-piece fan guard is provided to shield all moving parts. All fasteners are zinc plated for corrosion protection. FX heaters are built to last. All FX products are subjected to exhaustive technical analysis and testing during design and development, and are manufactured under a registered quality assurance program. As a result, they have consistently proven their safety and reliability. For hazardous location heating, rely on the King FX6 heater for the most dependable, trouble-free service available. Suitable for the following hazardous location classifications: •Class I, Divisions 1 & 2, Groups C & D, •Class II, Divisions 1 & 2, Groups E, F & G, •Class I, Zones 1 & 2, Groups IIA & IIB, •Temperature Code T3B 165°C (329°F)

Engineering Specifications

Contractor shall supply and install FX6 Series unit heaters manufactured by King Electrical Mfg. Company. Heaters shall be of the wattage and voltage as indicated on the plans.

Hazardous Locations Classifications: Class I, Divisions 1 & 2, Group C & D • Class II, Divisions 1 & 2, Group E, F & G • Class I, Zones 1 & 2, Group IIA & IIB • Temperature Code T3B (329°F) (165°C)

Enclosures: NEMA Type 7 & 9. For dry, indoor use only. Do not immerse in water. Do not store or use in areas exposed to rain or snow

Motor Type: Explosion-proof. Thermally protected. Permanently lubricated ball bearings.

Fan: Aluminum blade. Steel spider and hub with 5/8" (15.875 mm) bore.

Fan Guard: Split design with close wire spacing. 1/4" (6.3 mm) diameter probe will not enter.

Mounting Holes: Two 9/16" (14.3 mm) diameter holes at the top of heater.

Heating Elements: Three Long-life metal-sheathed elements.

Temperature High-Limit: Automatic reset type, snap-action bimetal, open on temperature rise. Rated 100,000 cycles at 10 amps, handles 0.128 amps

Control Circuit: 120V, 0.128 amps, 15VA. (Grounded).

Safety Protection Circuit: Snap action bimetal switch, rated for 100,000 cycles at 10 amps. Part of secondary thermal protection circuit with dedicated contactor. Independent of main control circuit.

Slim Junction Box: 10.25" (230 mm) x 8.00" (180 mm) x 6.75" (172 mm)

Optional Built-In Thermostat: Explosion-proof. 36°F to 82°F (2°C to 28°C)

Optional Built-In Disconnect Switch: DS for use only on heaters with total current not exceeding 48 amps. Lockout handle accepts 1/4" diameter padlock shackle

Optional Pilot Light: Explosion-proof light fixture with replaceable bulb

Control Transformer: Multiple voltage primary, 120V secondary, 50VA.

Contactors: 75 amps. Rated for 1,000,000 mechanical operations. 120 V, 15 VA coil (separately fuse-protected)

Heat Transfer Fluid: Proprietary heat transfer fluid

Cabinet Material: 12 ga. (0.104") (2.60 mm) steel. Epoxy coated with five-stage pretreatment, including iron phosphate. Optional stainless steel.

Core: Steel with integral aluminum fins, vacuum charged and hermetically sealed

Conduit Material: Heavy walled, 0.122" (3.1 mm) steel

Overpressure Protection: Preset 100 psig (690 kPa) pressure relief valve, no field serviceable parts. Preset 300 PSIG (2070 kPa) rupture disk, no field serviceable parts.

Operational Temperature Range: -58°F to 104°F (-50°C to 40°C)

Storage Limitations: -58°F to 176°F (-50°C to 80°C). Do not immerse in water. Do not expose to rain or snow.

Explosion-Proof Heater Model FX6

Ordering Information - Performance Data for 60 Hertz FX6- UL, Temperature Code T3B (328°F) 165°C

MODEL	VOLTS	PHASE	NOMINAL WATTAGE (kW)	AMPS	OPTIONAL BUILT-IN DISCONNECT SWITCH	AIR TEMP. RISE	BTU/HR
FX6-208160-030	208	1	3	18.5	DS	19°F (10.5°C)	10,250
FX6-208360-030	208	3	3	10.6	DS	19°F (10.5°C)	10,250
FX6-240160-030	240	1	3	16.6	DS	19°F (10.5°C)	10,250
FX6-240360-030	240	3	3	9.6	DS	19°F (10.5°C)	10,250
FX6-480160-030**	480	1	3	7.1	DS	19°F (10.5°C)	10,250
FX6-480360-030	480	3	3	4.8	DS	19°F (10.5°C)	10,250
FX6-600360-030	600	3	3	3.6	DS	19°F (10.5°C)	10,250
FX6-208160-050	208	1	5	28.1	DS	31.6°F (17.6°C)	17,050
FX6-208360-050	208	3	5	16.2	DS	31.6°F (17.6°C)	17,050
FX6-240160-050	240	1	5	24.9	DS	31.6°F (17.6°C)	17,050
FX6-240360-050	240	3	5	14.4	DS	31.6°F (17.6°C)	17,050
FX6-480160-050**	480	1	5	11.2	DS	31.6°F (17.6°C)	17,050
FX6-480360-050	480	3	5	7.2	DS	31.6°F (17.6°C)	17,050
FX6-600360-050	600	3	5	5.5	DS	31.6°F (17.6°C)	17,050
FX6-208160-075	208	1	7.5	40.2	DS	27.9°F (15.5°C)	25,600
FX6-208360-075	208	3	7.5	23.1	DS	27.9°F (15.5°C)	25,600
FX6-240160-075	240	1	7.5	35.4	DS	27.9°F (15.5°C)	25,600
FX6-240360-075	240	3	7.5	20.5	DS	27.9°F (15.5°C)	25,600
FX6-480160-075**	480	1	7.5	16.4	DS	27.9°F (15.5°C)	25,600
FX6-480360-075	480	3	7.5	10.2	DS	27.9°F (15.5°C)	25,600
FX6-600360-075	600	3	7.5	7.9	DS	27.9°F (15.5°C)	25,600
FX6-208160-100**	208	1	10	52.2	NOT AVAILABLE	37.2°F (20.6°C)	34,100
FX6-208360-100	208	3	10	30.1	DS	37.2°F (20.6°C)	34,100
FX6-240160-100	240	1	10	45.8	DS	37.2°F (20.6°C)	34,100
FX6-240360-100	240	3	10	26.5	DS	37.2°F (20.6°C)	34,100
FX6-480160-100 ¹	480	1	10	21.6	DS	37.2°F (20.6°C)	34,100
FX6-480360-100	480	3	10	13.2	DS	37.2°F (20.6°C)	34,100
FX6-600360-100	600	3	10	10.3	DS	37.2°F (20.6°C)	34,100
FX6-208360-150	208	3	15	44	NOT AVAILABLE	27.1°F (15.1°C)	51,200
FX6-240160-150*	240	1	15	66.6	DS	27.1°F (15.1°C)	51,200
FX6-240360-150	240	3	15	38.5	DS	27.1°F (15.1°C)	51,200
FX6-480160-150**	480	1	15	32.1	DS	27.1°F (15.1°C)	51,200
FX6-480360-150	480	3	15	19.3	DS	27.1°F (15.1°C)	51,200
FX6-600360-150	600	3	15	15.2	DS	27.1°F (15.1°C)	51,200
FX6-480160-200**	480	1	20	42.5	DS	36.1°F (20.1°C)	68,250
FX6-480360-200	480	3	20	25.3	DS	36.1°F (20.1°C)	68,250
FX6-600360-200	600	3	20	20	DS	36.1°F (20.1°C)	68,250
FX6-480360-250	480	3	25	31.3	DS	22.0°F (12.2°C)	85,300
FX6-600360-250	600	3	25	24.8	DS	22.0°F (12.2°C)	85,300
FX6-480360-300	480	3	30	37.3	DS	26.4°F (14.6°C)	102,350
FX6-600360-300	600	3	30	29.6	DS	26.4°F (14.6°C)	102,350
FX6-480360-350	480	3	35	43.3	DS	30.7°F (17.1°C)	119,450
FX6-600360-350	600	3	35	34.4	DS	30.7°F (17.1°C)	119,450

* Exceeds the 48 amp circuit limit of NEC 424-22. DS not available for these units.

**480 V: 1-phase units are certified for Class I, Div. 1, Group D and Class II, Div.1 Groups F & G

Options

ADD SUFFIX	DESCRIPTION
-T	Thermostat with slim junction box..
-D	Built-in disconnect switch.
-P	Built-in pilot light.
-S	3-way switch.

Continued

Explosion-Proof Heater Model FX6

Options

ADD SUFFIX	DESCRIPTION
-L	Large junction box.
-C	Heresite® coating.
-A	Stainless-steel cabinet.
-U	Continuous fan.

Ordering Information - Performance Data for 50 Hertz FX6, Temperature Code T3B (329°F) 165°C

MODEL	VOLTS	PHASE	NOMINAL WATTAGE (kW)	AMPS	OPTIONAL BUILT-IN DISCONNECT SWITCH	AIR TEMP. RISE	BTU/HR
FX6-220150-025	220	1	2.5	16.1	DS	19.7°F (11°C)	8,550
FX6-220150-042	220	1	4.2	23.8	DS	33.2°F (18.4°C)	14,350
FX6-220150-063	220	1	6.3	33.3	DS	28.5°F (15.7°C)	21,500
FX6-220150-084	220	1	8.4	42.9	DS	37.8°F (21.1°C)	28,700
FX6-220150-126*	220	1	12.6	62.0	NOT AVAILABLE	27.5°F (15.2°C)	43,000
FX6-230150-028	230	1	2.8	16.3	DS	22.1°F (12.3°C)	9,550
FX6-230150-046	230	1	4.6	24.1	DS	36.4°F (20.2°C)	16,000
FX6-230150-069	230	1	6.9	34.1	DS	31.1°F (17.2°C)	23,550
FX6-230150-138*	230	1	13.8	64.1	NOT AVAILABLE	30.1°F (16.6°C)	47,100
FX6-380350-025	380	3	2.5	4.9	DS	11.2°F (6.3°C)	8,550
FX6-380350-042	380	3	4.2	7.5	DS	19.0°F (10.5°C)	14,350
FX6-380350-063	380	3	6.3	10.7	DS	28.5°F (15.7°C)	21,500
FX6-380350-084	380	3	8.4	13.9	DS	37.8°F (21.1°C)	28,700
FX6-380350-125	380	3	12.5	20.1	DS	27.5°F (15.2°C)	42,700
FX6-380350-209	380	3	20.9	32.9	DS	22.0°F (12.1°C)	71,350
FX6-400350-028	400	3	2.8	5.1	DS	12.5°F (7.0°C)	9,550
FX6-400350-046	400	3	4.6	7.7	DS	20.7°F (11.5°C)	15,700
FX6-400350-069	400	3	6.9	11.1	DS	31.1°F (17.2°C)	23,550
FX6-400350-093	400	3	9.3	14.5	DS	42.0°F (23.2°C)	31,750
FX6-400350-139	400	3	13.9	21.1	DS	30.2°F (16.7°C)	74,450
FX6-400350-185	400	3	18.5	27.8	DS	40.2°F (22.3°C)	63,150
FX6-400350-231	400	3	23.1	34.5	DS	24.2°F (13.5°C)	78,850
FX6-415350-037	415	3	3.7	6.4	DS	16.6°F (9.2°C)	12,650
FX6-415350-075	415	3	7.5	11.6	DS	33.8°F (18.7°C)	25,600
FX6-415350-149	415	3	14.9	22.0	DS	32.5°F (18.1°C)	50,850
FX6-415350-224	415	3	22.4	32.4	DS	23.5°F (13.1°C)	76,450
FX6-440350-042	440	3	4.2	6.7	DS	19.0°F (10.5°C)	14,350
FX6-440350-084	440	3	8.4	12.2	DS	37.8°F (21.1°C)	28,700
FX6-440350-168	440	3	16.8	23.3	DS	36.5°F (20.3°C)	57,350
FX6-440350-209	440	3	20.9	28.7	DS	22.1°F (12.2°C)	71,350

* Exceeds the 48 amp circuit limit of NEC 424-22. DS not available for these units.

**480 V: 1-phase units are certified for Class I, Div. 1, Group D and Class II, Div.1 Groups F & G

Specifications - 60 Hertz FX6

NOMINAL WATTAGE (kW)	MAX. ALTITUDE (FT)	AIR DELIVERY @70°F (CFM)	HORIZONTAL THROW (FT)	MAX. MOUNTING HEIGHT (FT)	MOTOR POWER (W)	MOTOR SPEED (RPM)	FAN DIAMETER (in)	NET WEIGHT (lbs)		SHIPPING WEIGHT (lbs)	
								WITH DS5	WITHOUT DS5	WITH DS5	WITHOUT DS5
3	12,000	850	30	10	373	1,725	12	152	140	206	194
5	8,000	850	30	10	373	1,725	12	152	140	206	194
7.5	10,000	850	30	10	373	1,725	12	152	140	206	194
10	7,000	850	30	10	373	1,725	12	152	140	206	194
15	10,000	1,750	40	10	373	1,725	16	180	168	230	218
20	7,000	1,750	40	10	373	1,725	16	180	168	230	218
25	10,000	3,600	70	20	373	1,725	20	213	201	264	252
30	7,000	3,600	70	20	373	1,725	20	213	201	264	252
35	6,000	3,600	70	20	373	1,725	20	213	201	264	252

Manufacturer reserves the right to replace motors with suitable alternate. Weights are an approximate maximum

Explosion-Proof Heater Model FX6

Specifications - 50 Hertz FX6

NOMINAL WATTAGE (kW)	MAX. ALTITUDE (FT)	AIR DELIVERY @70°F (CFM)	HORIZONTAL THROW (FT)	MAX. MOUNTING HEIGHT (FT)	MOTOR POWER (W)	MOTOR SPEED (RPM)	FAN DIAMETER (in)	NET WEIGHT (lbs)		SHIPPING WEIGHT (lbs)	
								WITH DS5	WITHOUT DS5	WITH DS5	WITHOUT DS5
2.5	12,000	700	25	10	187	1,437	12	152	140	206	194
3.7 & 4.2	8,000	700	25	10	187	1,437	12	152	140	206	194
6.3 & 7.5	10,000	700	25	10	187	1,437	12	152	140	206	194
8.4	7,000	700	25	10	187	1,437	12	152	140	206	194
12.5 & 12.6	10,000	1,450	35	10	187	1,437	16	180	168	230	218
14.9 & 16.7	7,000	1,450	35	10	187	1,437	16	180	168	230	218
20.9	10,000	3,000	60	20	187	1,437	16	213	201	264	252
22.4	7,000	3,000	60	20	187	1,437	16	213	201	264	252

Manufacturer reserves the right to replace motors with suitable alternate. Weights are an approximate maximum

Dimensional Data

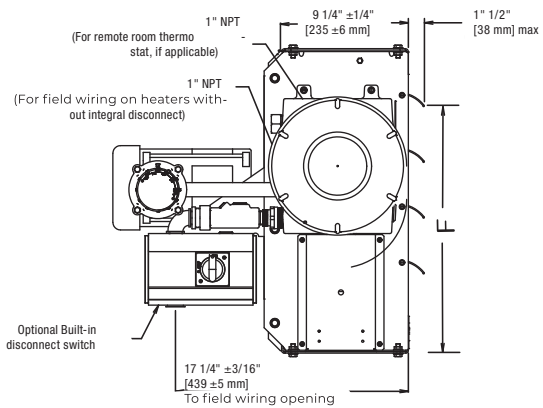
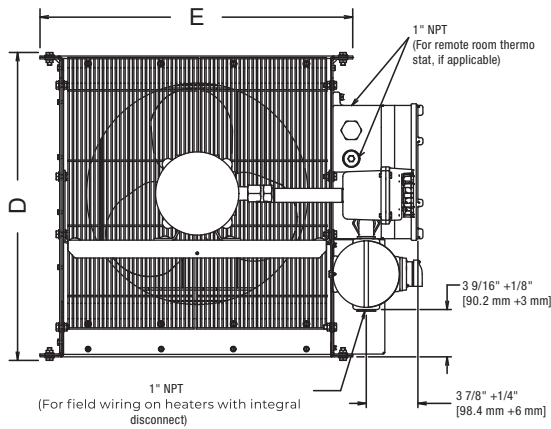

Dimensional Tolerances +1/8" [+3 mm] Unless otherwise specified.

DIM.	kW	kW			DIM. TOL. ±
		2.5-10	12.5-20	20.9-35	
A	in.	7	7	7	1/8
	mm	178	178	178	3
B	in.	18-3/16	22-5/16	26-1/4	1/8
	mm	462	566	667	3
C	in.	27	31	35	3/16
	mm	686	787	889	4
D	in.	19	23	27	1/8
	mm	484	586	688	3
E	in.	19-7/16	23-7/16	27-7/16	3/8
	mm	492	596	697	10
F	in.	17-1/2	19-1/2	21-13/16	5/16
	mm	444	495	554	8
G	in.	24-5/8	28-5/8	32-5/8	3/16
	mm	625	727	828	4

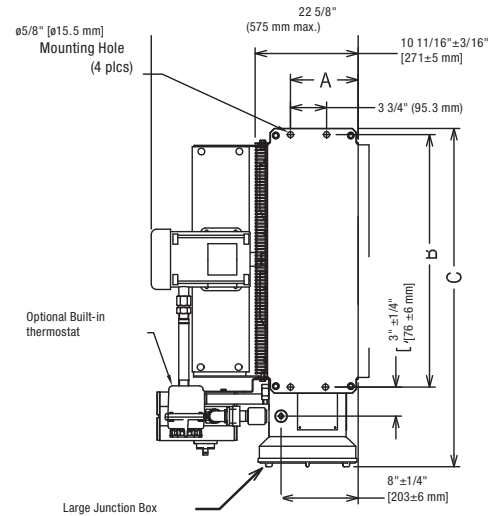
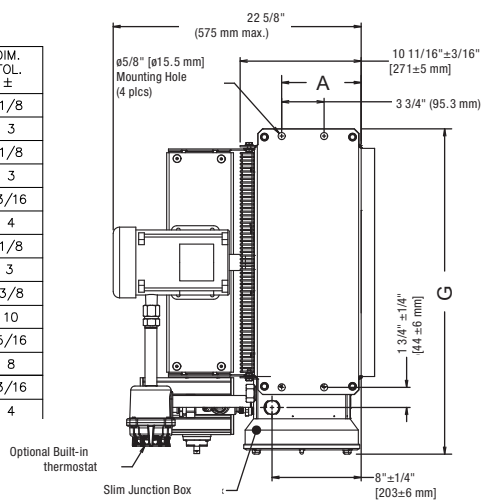

Explosion-Proof Heater Model FX6

