



# SUBMITTAL SHEET

Job Name: \_\_\_\_\_

Submitted By: \_\_\_\_\_

Date: \_\_\_\_\_

Location: \_\_\_\_\_

Architect: \_\_\_\_\_

Engineer: \_\_\_\_\_

Approved By: \_\_\_\_\_

Date: \_\_\_\_\_

Contractor: \_\_\_\_\_

Submitted By: \_\_\_\_\_

King Contact: \_\_\_\_\_

[Quotes@king-electric.com](mailto:Quotes@king-electric.com)

Date: \_\_\_\_\_

Tag	Qty	Item Number	Watts	Volts	PH	Amps	Weight

## Accessories

Tag	Qty	Item Number

# Compact Plenum Rated Heater KBU PlatinumX Series



## Model Code:

KBU 48 10 -3MP -PLTMX  
A B C D E

- A: Series
- B: 20 - 208V, 24 - 240/208V  
27 - 277V, 48 - 480V
- C: kiloWatts (1.67kW - 10kW)
- D: -1 = Single Phase  
-3MP = 1-3 Phase
- E: -PLTMX = Electronic Controller + 24V  
Remote Thermostat Provision

# PLATINUMX

- Plenum rated for concealed spaces: for zero clearance to combustibles
- For freeze protection in difficult to reach areas
- N.E.M.A. 12 construction
- Approved for installations in concealed spaces
- Compact low-profile design
- Energy-Saving PlatinumX electronic temperature controller
- Compatible with NEST / Any 24V thermostat, including WIFI stats
- 1-Stage heating 5kW and below + 3PH models
- 2-Stage heating 7.5kW & 10kW (1-PH models)
- Summer fan only & timer modes
- Auto Memory Feature: returns unit to last settings after power outage
- Axial fan
- Built-In Fan Delay to Dissipate Heat
- High Mass Steel Fin Heat Exchanger
- Safety Limit with audible alarm
- Patented Smart Limit Protection®
- Permanent Lubricated Unit Bearing Motor
- Low Profile Ceiling Mounting Bracket Included
- 2-Year Limited Warranty

## The KBU PlatinumX Compact Plenum Rated Heater

**KBU PlatinumX is a zero-clearance plenum-rated special application heater approved for use in concealed areas of buildings such as an area between a finished ceiling and drop ceiling or in an open plenum.** KBU-X fits seamlessly into tight spaces where warmth or freeze protection is required. It is engineered to withstand dirty, dusty, moist or even mildly corrosive environments, and rated for zero clearance mounting against any surface. KBU features an in-built electronic thermostat for accuracy and comes standard with a provision for adding an optional 24V thermostat for remote temperature control, making it compatible with Nest Thermostats. Includes integrated summer fan only and thermostat timer modes, the KBU PlatinumX has you covered. Spiral finned steel elements and high CFM ensure even air distribution producing cooler element operation, prolonging heater life. By combining the highest quality components, with a dynamically balanced fan blade, the KB PlatinumX unit heater will provide years of trouble-free service. Includes universal wall/ceiling bracket for simple installation.

### PlatinumX Electronic Controller Features

- Electronic control for accuracy
- Thermostat timer mode (1-9 Hours)
- Summer Fan only mode
- Large LED display
- Built-In fan delay
- Built-In provision for optional 24V remote thermostat
- Remote control and wall/ceiling bracket included
- Compatible with NEST / any 24V WIFI Stat

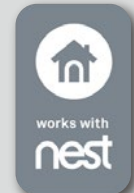

or Any 24V  
WIFI Stat

### Engineering Specifications

*Contractor shall supply and install KBU Platinum X Series compact plenum rated heaters manufactured by King Electrical Mfg. Company. Heaters shall be of the wattage and voltage as indicated on the plans.*

**Construction:** All exterior and interior metal enclosure parts are made from 20 gauge electrogalvanized Steel with a rust inhibiting baked enamel finish. Smooth rounded corners and protective edge trim give an attractive modern appearance.

**Electronic Control:** Up, down temperature mode. Start/Stop standard on all heaters.

**Auto Memory Feature:** Returns Unit To Last Settings After Power Outage.

**Front Outlet Screen:** Heavy gauge steel screen protects against foreign objects making accidental contact with the rotating fan blade.

**Rear Intake Screen:** Heavy gauge steel screen protects against foreign objects making accidental contact with the rotating fan blade.

**Spiral Fin Elements:** The metal sheath element is copper brazed with spiral fins then molded into a coil configuration. This combination produces the best heat transfer while eliminating the potential for hot spots by positioning the element in the maximum airflow stream.

**Totally Enclosed Fan Motor:** Permanently lubricated long life, unit bearing with 20cc of oil. Epoxy-coated motor with enclosed rotor resists moisture and corrosion for long-lasting, trouble-free operation.

**Aluminum Fan Blade:** Axial flow-type fan mounted directly to the motor shaft for maximum efficiency.

**Thermal Overload with Alarm:** Heaters shall be equipped with King's patented thermal overload Smart Limit Protection®, which disconnects elements and motor in the event normal operating temperatures are exceeded. If thermal overload trips due to abnormal operating temperatures, thermal overload shall remain open until manually reset by turning the heater off for 15 minutes. Automatically reset of thermal overloads, which allow the element to continue to cycle under abnormal conditions, will not be accepted. An audible alarm sounds when thermal overload limit trips.

**Internal Controls:** Magnetic contactors are standard on all 480V heaters, all 208V/1-Phase, 240V/1-Phase above 6kW, and all 3-Phase heaters.

**Provision For 24V Remote Thermostat:** Includes terminals to connect an optional 24V 2-Stage Thermostat. Compatible with NEST / any 24V WIFI Stat

**Easy Installation:** A quick access panel located on the bottom of the heater allows for quick wiring and easy maintenance for the life of the heater. Includes universal wall/ceiling bracket for simple installation.

**Approvals:** cULus (E41422)

# Compact Plenum Rated Heater KBU PlatinumX Series

## Ordering Information - single phase

	MODEL	UPC	KW	BTUH (000)	PHASE	VOLTS	AMPS	MOTOR HP	CFM	TEMP. RISE	AIR THROW	MAX. MOUNT HEIGHT	*SIZE	WT. (lbs.)
208V	KBU2001-1-PLTMX	70325	1.67	5.7	1	208	8	16W**	520	10°	15ft.	8ft.	A	30.5
	KBU2002-1-PLTMX	70326	2.5	8.5	1	208	12	16W**	520	15°	15ft.	8ft.	A	30.5
	KBU2003-1-PLTMX	70016	3.3	11.3	1	208	15.9	16W**	520	20°	15ft.	8ft.	A	30.5
	KBU2004-1-PLTMX	70017	4	13.7	1	208	19.2	16W**	520	24°	15ft.	8ft.	A	30.5
	KBU2005-1-PLTMX	70021	5	17.1	1	208	24.0	16W**	520	30°	15ft.	8ft.	A	30.5
	KBU2007-1-PLTMX	70025	7.5	25.6	1	208	36.1	25W**	690	34°	20ft.	9ft.	B	45.0
	KBU2010-1-PLTMX	70029	9.98	34.1	1	208	48.0	35W**	800	39°	24ft.	10ft.	B	45.0
240V	KBU2401-1-PLTMX	70327	1.67	5.7	1	240/208*	7/6*	16W	520	10°	15ft.	8ft.	A	30.5
	KBU2402-1-PLTMX	70328	2.5	8.5	1	240/208*	10.4/9*	16W	520	15°	15ft.	8ft.	A	30.5
	KBU2403-1-PLTMX	70329	3.3	11.3	1	240/208*	13.8/11.9*	16W	520	20°	15ft.	8ft.	A	30.5
	KBU2404-1-PLTMX	70018	4	13.5	1	240/208*	16.7/15*	16W	520	24°	15ft.	8ft.	A	30.5
	KBU2405-1-PLTMX	70022	5	17	1	240/208*	20.8/18*	16W	520	30°	15ft.	8ft.	A	30.5
	KBU2407-1-PLTMX	70026	7.5	25.6	1	240/208*	31.3/27*	25W	690	34°	20ft.	9ft.	B	45.0
	KBU2410-1-PLTMX	70030	10	34.1	1	240/208*	41.7/36.1*	35W	800	40°	24ft.	10ft.	C	45.0
277V	KBU2703-1-PLTMX	70330	3.3	11.3	1	277	11.9	9W	520	18°	15ft.	8ft.	A	30.5
	KBU2704-1-PLTMX	70019	4	13.5	1	277	14.4	9W	520	24°	15ft.	8ft.	A	30.5
	KBU2705-1-PLTMX	70023	5	17	1	277	18.1	9W	520	30°	15ft.	8ft.	A	30.5
	KBU2707-1-PLTMX	70027	7.5	25.6	1	277	27.1	25W	690	34°	20ft.	9ft.	B	45.0
	KBU2710-1-PLTMX	70370	10	34.1	1	277	36.1	35W	800	40°	24ft.	10ft.	C	45.0
480V	KBU4801-1-PLTMX	70331	1.67	5.7	1	480	3.5	16W	520	10°	15ft.	8ft.	A	30.5
	KBU4802-1-PLTMX	70332	2.5	8.5	1	480	5.2	16W	520	15°	15ft.	8ft.	A	30.5
	KBU4803-1-PLTMX	70333	3.3	11.3	1	480	6.9	16W	520	20°	15ft.	8ft.	A	30.5
	KBU4804-1-PLTMX	70020	4.2	14.2	1	480	8.7	16W	520	25°	15ft.	8ft.	A	30.5
	KBU4805-1-PLTMX	70024	5	17.1	1	480	10.4	16W	520	30°	15ft.	8ft.	A	30.5
	KBU4807-1-PLTMX	70028	7.5	25.6	1	480	15.6	25W	690	34°	20ft.	9ft.	B	45.0
	KBU4810-1-PLTMX	70031	10	34.1	1	480	20.8	35W	800	40°	24ft.	10ft.	C	45.0

\*Dual rated heaters will draw 13% less amps and 25% less wattage when operated at 208V. \*\*240V motor derated for 208V operation.

## Ordering Information - multi-phase

	MODEL	UPC	KW	BTUH (000)	PHASE	VOLTS	AMPS	MOTOR HP	CFM	TEMP. RISE	AIR THROW	MAX. MOUNT HEIGHT	*SIZE	WT. (lbs.)
208V	KBU2003-3MP-PLTMX	70334	3	10.2	1-3	208	14.4/8.3	16W**	520	18°	20ft.	8ft.	C	45.0
	KBU2005-3MP-PLTMX	70033	5	17.1	1-3	208	24 & 13.9	16W**	520	30°	20ft.	8ft.	C	45.0
	KBU2007-3MP-PLTMX	70036	7.5	25.6	1-3	208	36.1 & 20.8	25W**	690	34°	24ft.	9ft.	C	46.5
	KBU2010-3MP-PLTMX	70039	9.98	34.1	1-3	208	48/27.7	35W**	800	39°	29ft.	11ft.	C	46.5
240V	KBU2403-3MP-PLTMX	70335	3	10.2	1-3	240/208*	12.5/7.2* & 10.8/6.2*	9W	520	18°	20ft.	8ft.	C	45.0
	KBU2405-3MP-PLTMX	70034	5	17.1	1-3	240/208*	20.8/18* & 18/15.6*	9W	520	30°	20ft.	8ft.	C	45.0
	KBU2407-3MP-PLTMX	70037	7.5	25.6	1-3	240/208*	31.2/27* & 18/15.6*	16W	690	34°	24ft.	9ft.	C	46.5
	KBU2410-3MP-PLTMX	70040	10	34.1	1-3	240/208*	41.7/36.1* & 24.1/20.8*	25W	800	40°	29ft.	11ft.	C	46.5
480V	KBU4803-3MP-PLTMX	70333	3	10.2	1-3	480	6.3/3.6	9W	520	18°	20ft.	8ft.	C	45.0
	KBU4805-3MP-PLTMX	70035	5	17.1	1-3	480	10.4 & 6.0	9W	520	30°	20ft.	8ft.	C	45.0
	KBU4807-3MP-PLTMX	70038	7.5	25.6	1-3	480	15.6/9	16W	690	34°	24ft.	9ft.	C	46.5
	KBU4810-3MP-PLTMX	70041	10	34.1	1-3	480	20.8 & 12	25W	800	40°	29ft.	11ft.	C	46.5

\*Dual rated heaters will draw 13% less amps and 25% less wattage when operated at 208V. \*\*240V motor derated for 208V operation.

# Compact Plenum Rated Heater KBU PlatinumX Series

## Field Mount Options

ADD SUFFIX:	UPC	DESCRIPTION	WT. (lbs.)
DS32	13480	Disconnect Switch, Field Installed Kit, 32 AMP, 600V	2.0
DS63	13481	Disconnect Switch, Field Installed Kit, 63 AMP, 600V	2.0
DS80	13482	Disconnect Switch, Field Installed Kit, 80 AMP, 600V	2.0
DS100	13483	Disconnect Switch, Field Installed Kit, 100 AMP, 600V	5.0

## Replacement Accessories

MODEL	UPC	DESCRIPTION	WT. (lbs.)
ECO2S-REMOTE	33489	ECO2S Replacement Infrared Remote Control	0.1
ECO2S-REMOTE-BRACKET	33490	ECO2S Replacement Infrared Remote Control Wall Mount Bracket	.04
KBHK	13487	Replacement Hardware Kit	0.1

## Field Installed Optional Accessories

MODEL	UPC	DESCRIPTION	WT. (lbs.)
KBB-1	13484	Replacement Universal Wall/Ceiling Small Mounting Bracket (for heaters with size A heaters)	1.9
KBB-2	13485	Replacement Universal Wall/Ceiling Large Mounting Bracket (for heaters with size B and C)	2.6
KBB-3	13488	Replacement Universal Wall/Ceiling Large Mounting Bracket (for heaters with size F & G)	3.9
KBHS	13486	Replacement Hook Swivel	0.4

## Bracket Selection Chart

BRACKET #	HEATER KW SIZE USED WITH	BRACKET DIMENSIONS											
		L	W	H	A	B	C	D	E	F	X	Y	Z
KBB-1	3 to 5 kW (1 phase)	12½"	2 <sup>15</sup> / <sub>16</sub> "	10 <sup>1</sup> / <sub>16</sub> "	1 <sup>3</sup> / <sub>16</sub> "	7"	1 <sup>7</sup> / <sub>8</sub> "	1 <sup>7</sup> / <sub>8</sub> "	9¼"	1 <sup>7</sup> / <sub>8</sub> "	¾"	1"	½"
KBB-2	7.5 to 10 kW (1 phase) 3 to 20 kW (3 phase)	16 <sup>7</sup> / <sub>8</sub> "	2 <sup>15</sup> / <sub>16</sub> "	10 <sup>1</sup> / <sub>8</sub> "	1¼"	7"	1 <sup>7</sup> / <sub>8</sub> "	1 <sup>5</sup> / <sub>8</sub> "	13 <sup>5</sup> / <sub>8</sub> "	1 <sup>5</sup> / <sub>8</sub> "	¾"	1"	1½"
KBB-3	25 to 40 kW (3 phase)	19½"	4 <sup>3</sup> / <sub>16</sub> "	13 <sup>3</sup> / <sub>16</sub> "	1 <sup>5</sup> / <sub>16</sub> "	10"	1 <sup>7</sup> / <sub>8</sub> "	1 <sup>5</sup> / <sub>8</sub> "	16¼"	1 <sup>1</sup> / <sub>8</sub> "	11 <sup>1</sup> / <sub>16</sub> "	1"	2"

## Dimensional Data

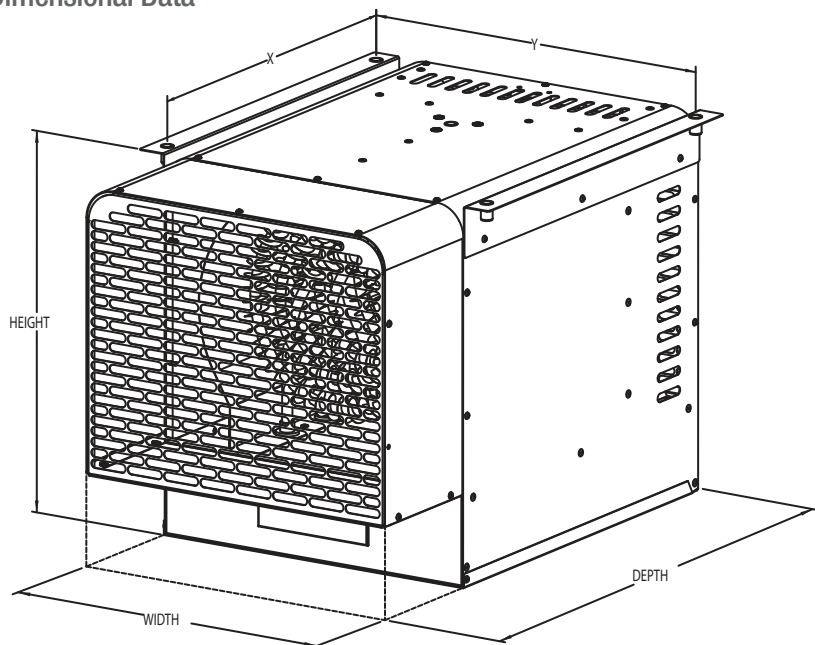

HEATER SIZE	HEIGHT	DEPTH	WIDTH	X	Y
A	16.5"	17"	15"	9"	16"
B	16.5"	19.5"	15"	11.5"	16"
C	16.5"	24"	15"	16"	16"