

Pumphouse Heater U-SS Series



Model Code:

U	24	10	SS
A	B	C	D

A: Series
 B: 12 - 120V 20- 208V
 24 - 240V
 C: Watts (1000)
 D: -SS Stainless Steel



Rated for damp locations

- ETL listed for use in damp locations
- Available in stainless steel (-SS) or painted gray
- Designed to meet requirements outlined in ASSE-1060
- Built-in thermostat with frost protection (40° to 90°F)
- Standard baked enamel protective coating
- Built in mounting bracket
- Convection/Radiant heat
- Vertical (Up to 500W) or horizontal mount
- 1-year limited warranty



The U-SS Series Pumphouse Heater

The U-SS Series heater is designed to reduce moisture from mechanical equipment and keep pumps, valves, and farm machinery from freezing. Having the radiant heat absorbed by the metal equipment makes this heater more effective than convection heaters.

The built-in thermostat turns off when the ambient temperature is safely above freezing. Helps prevent corrosion associated with high moisture locations like pump houses. A steel guard helps keep foreign objects away from the element. This heater is simple and reliable with no moving parts to wear out or maintain, making it an inexpensive choice for freeze protection. Specifically designed to operate in both horizontal (full wattage) or vertical (up to 500W) positions.

Ordering Information

	MODEL	UPC#	VOLTAGE	WATTAGE	WEIGHT lbs
120V	U1250-SS	12627	120	500	4
	U1275-SS	12630	120	750	4
	U12100-SS	12633	120	1000	4
240V	U2425-SS	12634	240/208/120*	250/187/62	4
	U2450-SS	12635	240/208/120*	500/375/125	4
	U2475-SS	12636	240/208/120*	750/563/187	4
	U24100-SS	12637	240/208/120*	1000/750/250	4

*Triple rated 240V heaters will draw 13% less amps and 25% less wattage when operated at 208V / Draw 50% less amps and 75% less wattage when operated at 120V

Dimensional Data

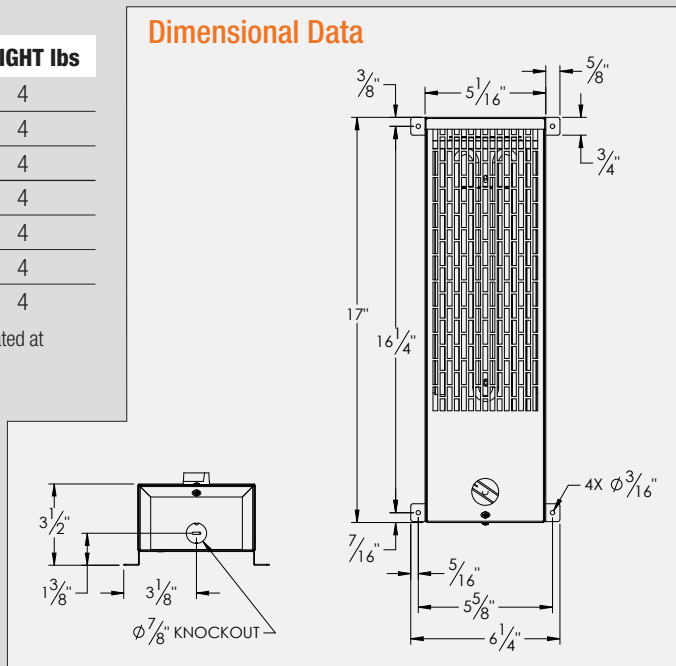

Engineering Specifications

Contractor shall supply and install U Pump House series radiant heaters manufactured by King Electrical Mfg. Company. Heaters shall be of the wattage and voltage as indicated on the plans.

Element: Incoloy 840 Superalloy, corrosion resistant element

Thermostat: Built-in snap action with a range of 40° to 90°F.

Safety Limit: Capillary tube running the full length of the element provides over-temperature protection then automatically resets when temperature drops.

Enclosure: Stainless Steel case.

Safety Standard: ETLus